

Parts List for 1-056-900 Series (rev. A & B) Manual Adjust Brakes

For Installation and Service Instructions refer to sheet part number 8-078-905-60. Instructions and parts list also available at www.rexnord.com.

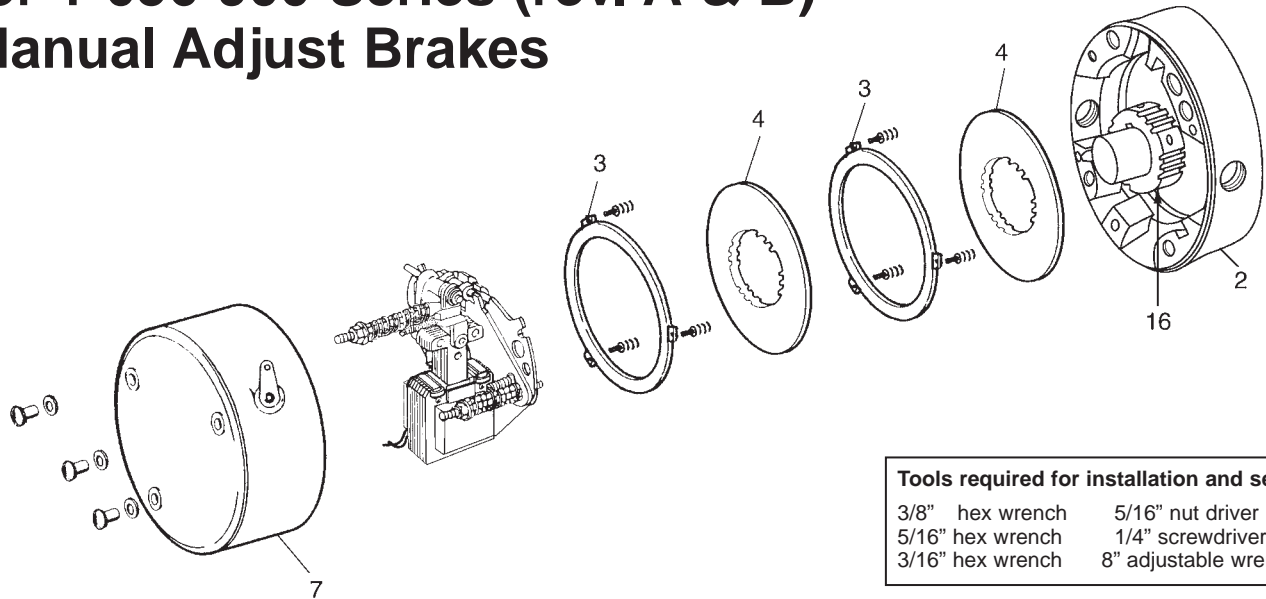

Tools required for installation and servicing:

3/8" hex wrench	5/16" nut driver
5/16" hex wrench	1/4" screwdriver
3/16" hex wrench	8" adjustable wrench

Typical Nameplate

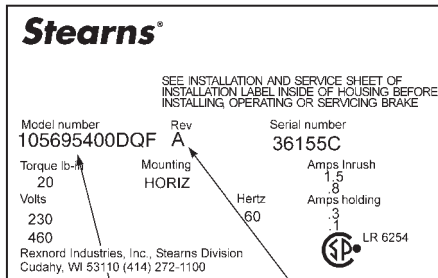

MODEL NUMBER
will appear on brake
nameplate.

REVISION CONTROL

IMPORTANT

Please read these instructions carefully before installing, operating, or servicing your Stearns Brake. Failure to comply with these instructions could cause injury to personnel and/or damage to property if the brake is installed or operated incorrectly. For definition of limited warranty/liability, contact Rexnord Industries, Inc., Stearns Division, 5150 S. International Dr., Cudahy, WI 53110, (414) 272-1100.

Caution

1. Installation and servicing must be made in compliance with all local safety codes including Occupational Safety and Health Act (OSHA). All wiring and electrical connections must comply with the National Electric Code (NEC) and local electric codes in effect.

2. Do not operate the brake in atmospheres containing explosive gases or dusts.
3. To prevent an electrical hazard, disconnect power source before working on the brake. If power disconnect point is out of sight, lock disconnect in the *off* position and tag to prevent accidental application of power.
4. Make certain power source conforms to the requirements specified on the brake nameplate.
5. Be careful when touching the exterior of an operating brake. Allow sufficient time for brake to cool before disassembly. Surfaces may be hot enough to be painful or cause injury.
6. Do not operate brake with housing removed. All moving parts should be guarded.
7. Installation and servicing should be performed only by qualified personnel familiar with the construction and operation of the brake.
8. For proper performance and operation, only genuine Stearns parts should be used for repairs and replacements.
9. After usage, the brake interior will contain burnt and degraded friction material dust. This dust must be removed before servicing or adjusting the brake.

DO NOT BLOW OFF DUST using an air hose. It is important to avoid dispersing dust into the air or inhaling it, as this may be dangerous to your health.

- a) Wear a filtered mask or a respirator while removing dust from the inside of a brake.
- b) Use a vacuum cleaner or a soft brush to remove dust from the brake. When brushing, avoid causing the dust to become airborne. Collect the dust in a container, such as a bag, which can be sealed off.

Caution! While the brake is equipped with a manual release to allow manual shaft rotation, the motor should not be run with the manual release engaged, to avoid overheating the friction disc(s).

Information required when ordering replacement parts:

- Give Part Number of parts or kits needed, Brake Model Number, and Brake Serial Number. The Brake Model and Serial Number may identify special brakes not covered by this parts list.
- When ordering hubs, specify shaft diameter (hub bore) and keyway.
- Enclosure is specified as follows:
NEMA 4X (formerly referred to as BISSC washdown)

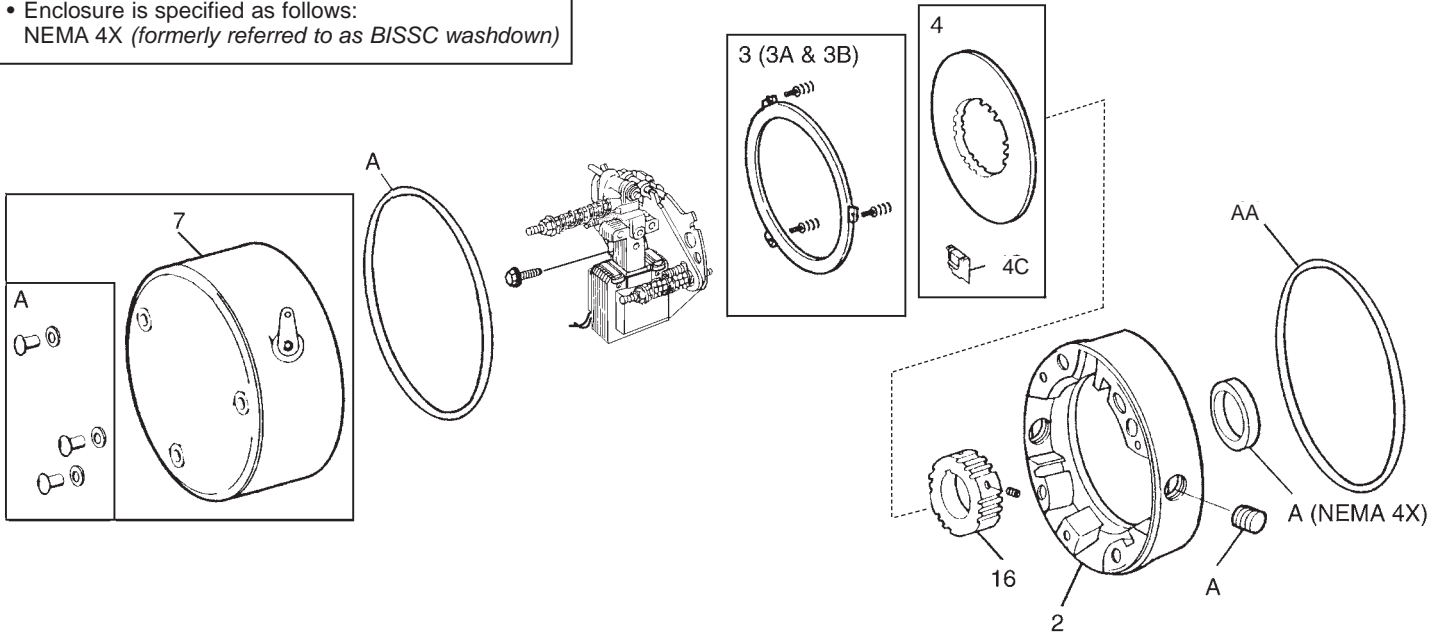

		Torque (lb-ft)		1.5 and 3		6		10		15		20 and 25	
		Current		AC	DC	AC	DC	AC	DC	AC	DC	AC	DC
NEMA Enclosure		4X	4X	4X	4X	4X	4X	4X	4X	4X	4X	4X	4X
Brake Model Number →		1-056-904-00 & 914-00	1-056-908-00 & 918-00	1-056-924-00	1-056-928-00	1-056-934-00	1-056-938-00	1-056-944-00	1-056-948-00	1-056-954-00 & 964-00	1-056-958-00 & 968-00		
AA	Gasket NEMA 4 (close coupled only)	8-122-503-00	X	X	X	X	X	X	X	X	X	X	X
A	Hardware Kit - NEMA 4X	5-66-1018-00	1	1	1	1	1	1	1	1	1	1	1
7	Housing & Release Assembly - NEMA 4X	5-07-5045-00	1	1	1	1	1	1	1	1	1	1	1
3	Stationary disc kit (1 disc universal; 3 disc horizontal)	5-66-8354-00	1	1	1	1						3	3
3A	Stationary disc kit (2 disc universal)	5-66-8355-00					1	1	1	1			
3B	Stationary disc kit (3 disc vertical)	5-66-8356-00										1	1
<i>Not Shown</i>	Vertical spring kit (3 disc)	5-63-0525-00								1	1	1	1
4	Friction disc kit	5-66-8462-00	1	1	1	1	2	2	2	2	3	3	3
4C	Stabilizing clip	5-66-8356-00	2	2	2	2	*	*	*	*	*	*	*
DP	Disc pack kit - 1 disc	5-66-8601-00	1	1	1	1							
	Disc pack kit - 2 disc	5-66-8602-00					1	1	1	1			
	Disc pack kit - 3 disc	5-66-8603-00									1	1	1
16	Hub and set screw assembly 1 disc	5/8 bore	5-16-5151-00-01B	1	1	1	1						
		7/8 bore	5-16-5151-00-01D	1	1	1	1						
		1-1/8 bore	5-16-5151-00-01E	1	1	1	1						
Hub and set screw assembly 2 & 3 1 disc	5/8 bore	5-16-5153-00-01B					1	1	1	1	1	1	1
	7/8 bore	5-16-5153-00-01D					1	1	1	1	1	1	1
	1-1/8 bore	5-16-5153-00-01E					1	1	1	1	1	1	1
2	Endplate Endplate Endplate & Seal Assembly	1 disc close coupled	8-002-580-22-30F	X	X	X	X	X	X	X	X	X	X
		2 & 3 disc	8-002-582-22-30F										
		1 disc (NEMA 4X)	5-02-5047-00	1	1	1	1						
	2 & 3 disc (NEMA 4X)	5-02-5048-00					1	1	1	1	1	1	1

* Certain multiple friction disc model numbers require a single stabilizer clip (4S) added to each friction disc. If your brake has these clips, they must be replaced when the friction disc is replaced. This clip is included as part of the friction disc kit 5-66-8462-00.
X - Model numbers with the number 8 in the 8th position indicate close coupled brakes.

Support Plate Assembly

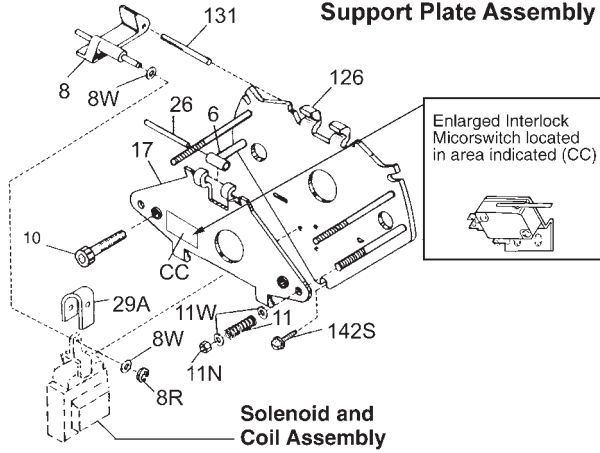

TABLE 2
Components of Support Plate and Coil Assembly

		Torque (lb-ft)						
		1.5 & 3	6	10	15	20	25	
		NEMA Enclosure						
		4X	4X	4X	4X	4X	4X	
		Support Plate Assy. (Items 6 through 131 and Z) →						
Item	Description	Part Number ↓	5-42-5601-00-34	5-42-5605-00-34	5-42-5607-00-34	5-42-5609-00-34	5-42-5611-00-34	5-42-5611-00-34
6	Bearing	8-006-501-00	1	1	1	1	1	1
8	Solenoid lever	8-008-504-01	1	1	1	1	1	1
8R	Retaining ring	9-03-0057-00	1	1	1	1	1	1
8W	Spacer	9-45-0168-00	2	2	2	2	2	2
11N	Torque adjustment nut	9-40-3928-00	2	2	2	2	2	2
10	Wear adjustment screw	9-17-8420-00	2	2	2	2	2	2
11	Pressure spring	9-70-1215-00	2					
	Pressure spring	9-70-1523-00		2	2			
	Pressure spring	9-70-1524-00				2	2	2
11W	Spring washer	9-46-0010-00		4	4	4	4	4
17	Lever arm and stop nut assy.	5-17-5011-00	1	1	1	1	1	1
26	Bearing pin	9-29-4826-00	1	1	1	1	1	1
29A	Plunger stop	8-094-503-00	1	1	1	1	1	1
126	Support plate and spring stud assembly (3 housing studs)	5-26-5020-00	1	1	1	1	1	1
131	Pivot pin	9-29-4836-00	1	1	1	1	1	1
142S	Mounting screws	9-25-9013-00	3	3	3	3	3	3
AC Brakes								
Z	No. 4 solenoid kit (rev A & B) (rev B only)	5-66-5047-00 5-96-5047-01	1 1	1 1	1 1	1 1	1 1	1 1
AC	No. 4 coil kit 60 Hz	115/230 Vac	5-66-6407-33	1				
		230/460 Vac	5-66-6409-33	1				
		115 Vac	5-66-6401-33	1				
		230 Vac	5-66-6402-33	1				
		460 Vac	5-66-6404-33	1				
		575 Vac	5-66-6405-33	1				
	No. K4 coil kit 60 Hz	115/230 Vac	5-66-6457-33		1	1		
		230/460 Vac	5-66-6459-33		1	1		
		115 Vac	5-66-6451-33		1	1		
		230 Vac	5-66-6452-33		1	1		
		460 Vac	5-66-6454-33		1	1		
		575 Vac	5-66-6455-33		1	1		
	No. K4+ coil kit 60 Hz	115/230 Vac	5-66-6407-23				1	1
		230/460 Vac	5-66-6409-23				1	1
		115 Vac	5-66-6401-23				1	1
		230 Vac	5-66-6402-23				1	1
460 Vac		5-66-6404-23				1	1	
575 Vac		5-66-6405-23				1	1	
No. M4+ coil kit 60 Hz	115/230 Vac	5-66-6457-23					1	
	230/460 Vac	5-66-6459-23					1	
	115 Vac	5-66-6451-23					1	
	230 Vac	5-66-6452-23					1	
	460 Vac	5-66-6454-23					1	
	575 Vac	5-66-6455-23					1	
CC	Brake release interlock switch (optional)	5-57-5526-00	1	1	1	1	1	1
DC Brakes								
AD	No. 4 + coil assembly	115 Vdc	5-96-6416-43	1				
		230 Vdc	5-96-6417-43	1				
	No. K4 + coil assembly	115 Vdc	5-96-6416-23		1	1		
		230 Vdc	5-96-6417-23		1	1		
No. M4 + coil assembly	115 Vdc	5-96-6466-23				1	1	
	230 Vdc	5-96-6467-23				1	1	
No. P4 + coil assembly	115 Vdc	5-96-6446-43					1	
	230 Vdc	5-96-6447-43					1	
BD	Electronic DC switch kit	24/28 Vdc	5-57-5712-15	1	1	1	1	1
		115 Vdc	5-57-5716-15	1	1	1	1	1
		230 Vdc	5-57-5717-15	1	1	1	1	1

Solenoid and Coil Assembly

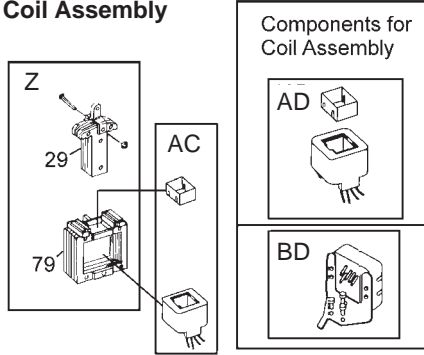

TABLE 3
Contents of Kits and Assemblies

Item	Kit Description
A	Hardware kit – NEMA 4X (5-66-1018-00) 1 – Endplate oil seal 1 – Drain plug 3 – Housing nuts 3 – Housing nut seal washers 2 – Endplate conduit pipe plugs 1 – Housing-to-endplate gasket
3	Stationary disc kit (5-66-8354-00) 1 – Stationary disc
3A	Stationary disc kit (5-66-8355-00) 2 – Stationary discs with springs
4	Friction disc kit (5-66-8462-00) 1 – Friction disc 2 – Stabilizing clips
DP	Disc pack kit (5-66-860X-00) 1, 2 or 3 – Friction disc(s) 1, 2 or 3 – Stationary disc(s) 2 – Stabilizing clips (5-66-8601-00 only) 3, 6 or 9 – Stationary disc separator springs
16	Hub and set screw assembly – all types, all bores (5-16-5153-00) 1 – Brake hub 2 – Set screws
Z	No. 4 solenoid kit (5-66-5047-00) (5-96-5047-01) 1 – Plunger 1 – Solenoid link 1 – Frame (including mounting bracket) 1 – Solenoid link cap screw 1 – Solenoid link nut 3 – Solenoid mounting screws
AC	No. 4 AC coil kit (5-66-64XX-X3) and DC coil assembly (5-96-64XX-X3)
AD	Coil / Top Plunger guide / Wire nut
BD	DC switch kit (5-57-571X-15) 1 – Electronic switch 1 – Mounting bracket 3 – Bracket mounting screws 4 – Switch mounting screws 4 – Nuts 4 – Lock washers 5 – Crimp connectors
CC	Brake release interlock switch (5-57-5526-00) 1 – Microswitch 1 – Mounting bracket 2 – Bracket mounting screws 2 – Switch mounting screws 2 – Lock washer 2 – Nuts 2 – Lead wire assembly

Optional Modification Kits

TABLE 4

Catalog Mod Number	Description	Part Number ↓	Torque (lb-ft)		
			1.5, 3 & 6	10 & 15	20 & 25
			Brake Model Number →		
			1-056-90X	1-056-91X	
			1-056-92X		
			1-056-93X		
			1-056-94X		
			1-056-95X		
			1-056-96X		
M4	Brass Stationary Disc	8-003-513-02	1	2	3
M13	Space Heater 115 Vac 230 Vac	5-27-2004-00 5-27-2005-00	1 1	1 1	1 1
M17	Terminal Strip	5-63-0524-00	1	1	1
M21	Vertical Spring Kit (2 disc) (3 disc)	5-63-0539-00 5-63-0525-00		1	1

Catalog Mod Number	Description	Part Number ↓	Torque (lb-ft)			
			1.5 & 3	10	15 & 20	25
			Brake Model Number →			
			1-056-904-00			
			1-056-914-00			
			1-056-924-00			
			1-056-934-00			
			1-056-944-00			
			1-056-954-00			
						1-056-964-00
M6	No. 4 Class 'H' coil kit 115 Vac 230 Vac 60 Hz	115/230 Vac	5-96-6407-05	1		
		230/460 Vac	5-96-6409-05	1		
		115 Vac	5-96-6401-05	1		
		230 Vac	5-96-6402-05	1		
		460 Vac	5-96-6404-05	1		
		575 Vac	5-96-6405-05	1		
	No. K4 Class 'H' coil kit 115 Vac 230 Vac 60 Hz	115/230 Vac	5-96-6457-05		1	
		230/460 Vac	5-96-6459-05		1	
		115 Vac	5-96-6451-05		1	
		230 Vac	5-96-6452-05		1	
		460 Vac	5-96-6454-05		1	
		575 Vac	5-96-6455-05		1	
No. K4+ Class 'H' coil kit 115 Vac 230 Vac 60 Hz	115/230 Vac	5-96-6407-25			1	
	230/460 Vac	5-96-6409-25			1	
	115 Vac	5-96-6401-25			1	
	230 Vac	5-96-6402-25			1	
	460 Vac	5-96-6404-25			1	
	575 Vac	5-96-6405-25			1	
No. M4+ Class 'H' coil kit 115 Vac 230 Vac 60 Hz	115/230 Vac	5-96-6457-25				1
	230/460 Vac	5-96-6459-25				1
	115 Vac	5-96-6451-25				1
	230 Vac	5-96-6452-25				1
	460 Vac	5-96-6454-25				1
	575 Vac	5-96-6455-25				1



Rexnord Industries, Inc.
Stearns Division
5150 S. International Drive
Cudahy, Wisconsin 53110
(414) 272-1100 Fax: (414) 277-4364 www.rexnord.com