

Torque (lb-ft)	125		175		230		330		440		550	
Current	AC	DC	AC	DC	AC	DC	AC	DC	AC	DC	AC	DC
Brake Model Number →	1-082-012-02	1-082-016-02	1-082-022-02	1-082-026-02	1-082-032-02	1-082-036-02	1-082-042-02	1-082-046-02	1-082-052-02	1-082-056-02	1-082-062-02	1-082-066-02

TABLE 2
Components for Standard Modifications

Type of Modification	Item No.	Description (most items not shown)	Part Number ↓	1-082-012-02	1-082-016-02	1-082-022-02	1-082-026-02	1-082-032-02	1-082-036-02	1-082-042-02	1-082-046-02	1-082-052-02	1-082-056-02	1-082-062-02	1-082-066-02
Vertical Mounting above Motor	2	Endplate and oil seal assembly w/pins	5-22-2014-00	1	1	1	1	1	1	1	1	1	1	1	1
	3	Endplate and oil seal assembly w/pins	5-22-2015-00												
	5	Stationary disc	8-003-206-02	1	1	1	1	2	2	2	2	3	3	4	4
		Pressure plate	8-005-205-02					1	1	1	1			1	1
		Pressure plate	8-005-206-02	1	1	1	1					1	1		
	61	Vertical mounting pin	8-061-208-00	4	4	4	4	4	4	4	4				
	62	Vertical mounting pin	8-061-209-00									4	4	4	4
		Vertical mounting spring (red)	9-70-1105-00											4	4
		Vertical mounting spring (white)	9-70-1004-00									4	4	4	4
		Vertical mounting spring (blue)	9-70-1005-00					4	4	4	4	4	4	4	4
		Vertical mounting spring (green)	9-70-1106-00	4	4	4	4	4	4	4	4	4	4	4	4
		Vertical mounting spring (yellow)	9-70-1006-00	4	4	4	4	4	4	4	4	4	4	4	4
	141	Spring spacer (brass)	8-138-207-00	*	*	*	*	*	*	*	*	*	*	*	*
		Spring spacer (stainless steel)	8-138-208-00	*	*	*	*	*	*	*	*	*	*	*	*
	170	Plunger guide bracket													
	170S	Cap screw (bracket)	kit												
	170W	Lock washer (bracket)	5-55-2002-00	1	1	1	1	1	1	1	1	1	1	1	1
171	Shim (bracket)														
172	Spacer														
	Release plate	} components of support plate - vertical mounting	8-170-105-00	1	1	1	1	1	1	1	1	1	1	1	
	Screw		9-16-3014-00	2	2	2	2	2	2	2	2	2	2	2	
	Lock nut		9-40-3730-00	2	2	2	2	2	2	2	2	2	2	2	
	Spring pin		9-32-4055-00	1	1	1	1	1	1	1	1	1	1	1	
	Release rod		8-146-201-01	1	1	1	1	1	1	1	1	1	1	1	
Foot Mounting	34	Foot mounting kit, comprised of:	5-55-2022-00												
	34S	Foot mounting bracket	8-034-205-01	1	1	1	1	1	1	1	1	1	1	1	
	39W	Cap screw	9-17-1624-00	4	4	4	4	4	4	4	4	4	4	4	
		Lock washer	9-45-0336-00	4	4	4	4	4	4	4	4	4	4	4	
Vertical Mounting below Motor	3	Stationary disc	8-003-206-02	1	1	1	1	2	2	2	2	3	3	4	4
	5	Pressure plate (less pins - Item 61)	8-005-205-03					1	1	1	1			1	1
		Pressure plate (less pins - Item 61)	8-005-206-03	1	1	1	1					1	1		
	61	Vertical mounting pin	8-061-210-00	4	4	4	4								
		Vertical mounting pin	8-061-211-00					4	4	4	4				
		Vertical mounting pin	8-061-212-00									4	4		
		Vertical mounting pin	8-061-213-00											4	4
	62	Vertical mounting spring (green)	9-70-1106-00											4	4
		Vertical mounting spring (black)	9-70-1007-00									4	4	4	4
		Vertical mounting spring (natural)	9-70-1008-00					4	4	4	4	4	4	4	4
		Vertical mounting spring (orange)	9-70-1009-00	4	4	4	4	4	4	4	4	4	4	4	4
	141	Spring spacer (brass)	8-138-207-00	*	*	*	*	*	*	*	*	*	*	*	*
		Spring spacer (stainless steel)	8-138-208-00	*	*	*	*	*	*	*	*	*	*	*	*
170	Plunger guide bracket (AC)	8-170-204-00	1	1	1	1	1	1	1	1	1	1	1	1	
170S	Cap screw (bracket)	8-350-002-00	2	2	2	2	2	2	2	2	2	2	2	2	
170W	Lock washer (bracket)	9-45-0330-00	2	2	2	2	2	2	2	2	2	2	2	2	
171	Shim (bracket)	8-454-016-00	*	*	*	*	*	*	*	*	*	*	*	*	
Brass Parts (horizontal brakes)	3	Stationary disc	8-003-208-01	1	1	1	1	2	2	2	2	3	3	4	4
	4	Friction disc	8-004-208-00	2	2	2	2	3	3	3	3	4	4	5	5
	5	Pressure plate	8-005-207-01					1	1	1	1			1	1
		Pressure plate	8-005-208-01	1	1	1	1					1	1		
Space Heater	not shown	Heater (115 volt circuit)	9-62-2058-00	1	1	1	1	1	1	1	1	1	1	1	1
		Heater (230 volt circuit)	9-62-2061-00	1	1	1	1	1	1	1	1	1	1	1	1
		Clamp (heater)	9-61-0077-00	1	1	1	1	1	1	1	1	1	1	1	1
		Screw	9-25-7321-00	1	1	1	1	1	1	1	1	1	1	1	1

*As required.

TABLE 3
Components of Support Plate Assemblies

Item No.	Description	Part Number ↓	Brake Size Torque (lb-ft)			
			125	175	230	330 440 550
			5-42-2071-34-09	5-42-2073-34-09	5-42-2075-34-09	5-42-2077-34-42
8	Solenoid lever and pinion assembly (comprised of Items 28, 32, 32R, 54, 71, 141 and 141A)	5-96-7382-00	1	1	1	1
11	Pressure spring (green)	9-70-4601-00	1			
	Pressure spring (yellow)	9-70-6001-00		1	1	
	Pressure spring (red)	9-70-5801-00				1
12	Solenoid assembly	see Table 4	1	1	1	1
13	Solenoid link	8-013-205-00	1	1	1	1
13B	Bearing (solenoid link)	9-04-1001-00	1	1	1	1
13C	Cap screw (solenoid link)	8-157-703-00	1	1	1	1
13N	Nut (solenoid link)	9-40-3732-00	1	1	1	1
17	Lever arm assembly	5-17-2001-00	1	1	1	1
17B	Pressure button	9-25-1908-00	2	2	2	2
17E	Eccentric sleeve (lever arm)	8-054-201-00	1	1	1	1
17S	Set screw (lever arm)	9-22-1004-00	2	2	2	2
19	Pressure spring nut	8-019-202-01	1	1	1	1
22	Solenoid lever stop	8-022-603-00	1	1	1	1
28	Solenoid lever (component of Item 8)		1	1	1	1
32	Pinion (component of Item 8)		1	1	1	1
32R	Retaining ring (component of Item 8)		1	1	1	1
53	Manual release spring tube	8-053-201-00	1	1	1	1
53P	Roll pin (spring tube)	9-32-4012-00	1	1	1	1
54	Sleeve (component of Item 8)		1	1	1	1
55	Actuator (component of Item 159)	8-170-211-00	1	1	1	1
55N	Nut (component of Item 159)	9-40-3730-00	1	1	1	1
55S	Machine screw (component of Item 159)	9-10-3040-00	1	1	1	1
59	Release spring	9-71-0004-00	1	1	1	1
71	Wrap spring (component of Item 8)		1	1	1	1
76	Wrap spring stop	8-076-203-00	1	1	1	1
76A	Holding plate (wrap spring stop)	8-076-204-00	1	1	1	1
76S	Cap screw (spring stop)	9-17-2812-00	2	2	2	2
76W	Lock washer (spring stop)	9-45-1328-00	2	2	2	2
126	Support plate and bearing assembly	5-26-2004-00	1	1	1	1
130	Pivot pin (lever arm)	8-118-204-00	1	1	1	1
131	Pivot pin (solenoid lever)	8-131-201-00	1	1	1	1
131R	Retaining ring (pivot pin)	9-03-0020-00	5	5	5	5
132	Cap screw (solenoid mounting)	8-350-008-00	4	4	4	4
132H	Holding plate (solenoid mounting)	8-076-207-00	2	2	2	2
132L	Lock plate (solenoid mounting)	8-076-206-00	2	2	2	2
134	Pressure spring spacer	8-134-001-02	1	1		
	Pressure spring spacer	8-134-001-03			1	
	Pressure spring spacer	8-134-001-05				1
138	Bearing (washer type)	8-138-201-00	8	8	8	8
138A	Bearing (washer type)	8-138-701-00	2	2	2	2
141	Wrap spring spacer	} component of item 8	*	*	*	*
141A	Wrap spring sleeve spacer		1	1	1	1
146	Release rod	8-146-201-00	1	1	1	1
146B	Ball bearing (release rod)	9-01-6801-00	1	1	1	1
146R	Retaining ring (release rod)	9-03-0007-00	1	1	1	1
152	Pressure spring stud	8-152-201-00	1	1	1	1
152P	Pivot pin (spring stud)	8-118-202-00	1	1	1	1
152R	Retaining ring (spring stud)	9-03-0019-00	2	2	2	2
159	Brake release interlock kit (side manual release)	5-55-2004-00	1	1	1	1
178	Instruction plate	8-078-054-00	1	1	1	1
178S	Drivescrew	9-25-1303-00	2	2	2	2
179	Solenoid mounting plate	8-179-205-01	1	1	1	1
179G	Grommet (mounting plate)	8-147-202-00	3	3	3	3
179S	Shoulder screw (mounting plate)	9-26-1108-00	3	3	3	3
179W	Washer (mounting plate)	8-138-202-00	3	3	3	3
170	Manual release plate	8-170-105-00	1	1	1	1
170S	Release plate screw	9-16-3014-01	2	2	2	2
170N	Release plate nut	9-40-3730-00	2	2	2	2

*As required

Support Plate Assembly

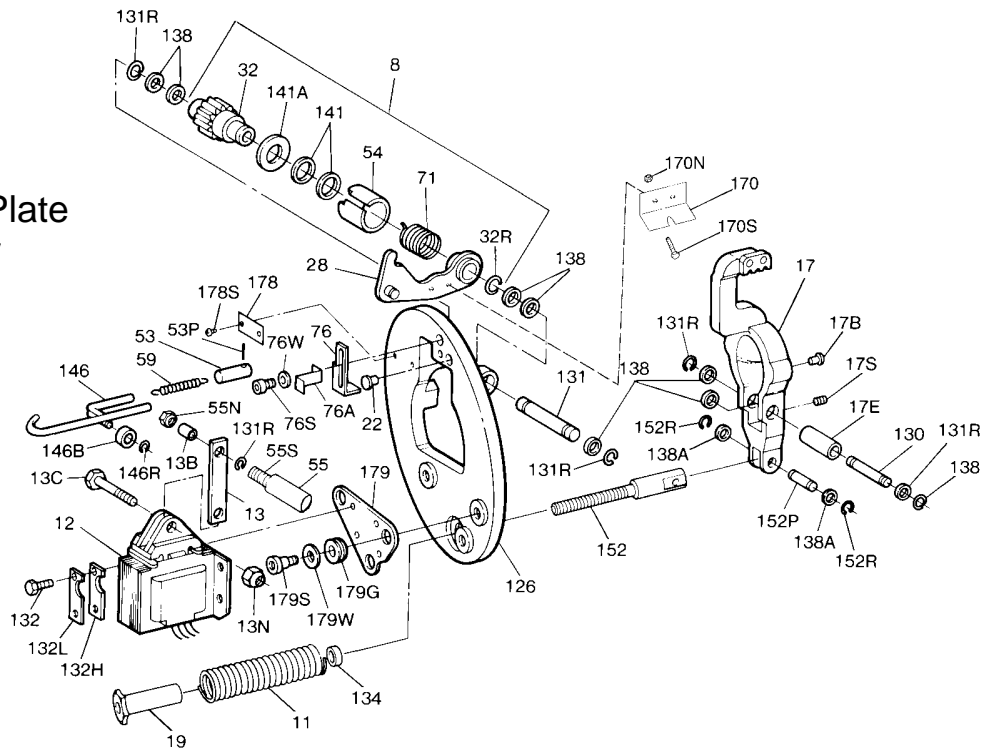
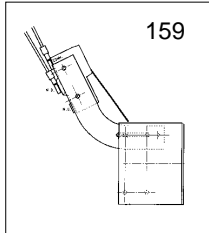

Solenoid and Coil Assembly

TABLE 4 – Components of Solenoid and Coil Assemblies

Item	Description	Part Number	Torque (lb-ft)		
			125/175/230	330/440/550	
12	Solenoid assembly	5-12-5529-00	1	1	
AC Brakes					
12A	No. 9 coil assembly 60 Hz	115 Vac	5-96-6901- **	1	
		230 Vac	5-96-6902- **	1	
		460 Vac	5-96-6904- **	1	
		575 Vac	5-96-6905- **	1	
		115/230 Vac	5-96-6907- **	1	
		230/460 Vac	5-96-6909- **	1	
12A	No. K9 coil assembly 60 Hz	115 Vac	5-96-6951- **		1
		230 Vac	5-96-6952- **		1
		460 Vac	5-96-6954- **		1
		575 Vac	5-96-6955- **		1
		115/230 Vac	5-96-6957- **		1
		230/460 Vac	5-96-6959- **		1
DC Brakes					
12A	No. 9 coil assembly	115 Vdc 230 Vdc	5-96-6916- ** 5-96-6917- **	1 1	1 1
157	DC switch kit	115 Vdc 230 Vdc	5-57-5716-02 5-57-5717-02	1 1	1 1

**-.05 (green coil) indicates class H coil.
 -.33 (black coil) indicates class B coil.

TABLE 5 – Contents of Assemblies and Kits

Item No.	Description
12	Solenoid assembly (5-12-5529-00) 1 - Plunger 1 - Frame 2 - Lock plates 1 - Solenoid link cap screw 1 - Solenoid link nut 1 - Cable clamp and screw (DC only)
12A	Coil assembly (5-96-69XX-**) <ul style="list-style-type: none"> 1 - Coil 2 - Plunger guides 2 - Plunger guide screws
157	DC switch kit (5-57-57XX-02) <ul style="list-style-type: none"> 1 - DC switch 2 - Mounting screws 2 - Lock washers
159	Brake switch kit (5-55-2004-00) (brake release interlock switch - N.O.) <ul style="list-style-type: none"> 1 - Microswitch 1 - Bracket, microswitch 1 - Bracket, mounting 1 - Mounting hardware
7R	Full release kit (5-55-2007-00) <ul style="list-style-type: none"> 1 - Release lever 1 - Spring pin 1 - O - ring 1 - Release handle 1 - Locking plate 1 - Assembly hardware

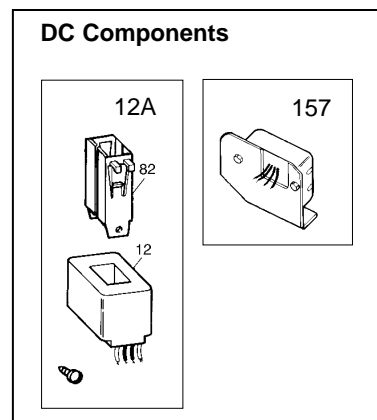
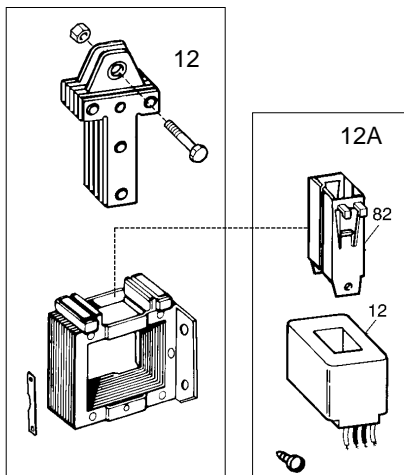

Copyright© 2000 by Rexnord Industries, Inc.

Rexnord Industries, Inc.
 Stearns Division
 5150 S. International Dr.,
 Cudahy, Wisconsin 53110
 (414) 272-1100

Fax: (414) 277-4364 www.rexnord.com