

Parts List for 55,000 Series Brakes

Information required when ordering replacement parts:

- When ordering brake parts, give part number of parts or kits needed, brake model number and brake serial number. The brake model and serial number may identify special brakes not covered by this parts list.
- Description items in ***CAPITALIZED BOLD ITALICS*** are recommended spare parts. One set per 5 brakes in service is recommended.
- When ordering hubs, specify shaft diameter (hub bore) and keyway. Consult factory for bores not listed.
- Enclosures are designated as follows:
O = Standard
E = Dust-tight, waterproof (DTWP)

For installation and service instructions, see P/N 8-078-925-00.
Detailed service instruction sheet is included with each kit.

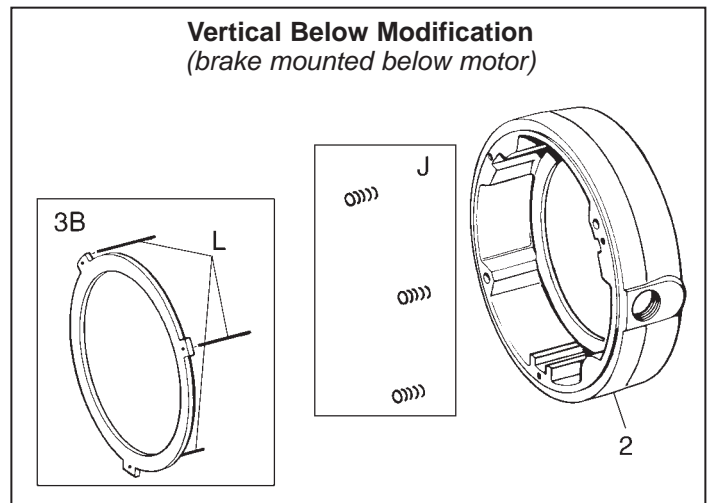
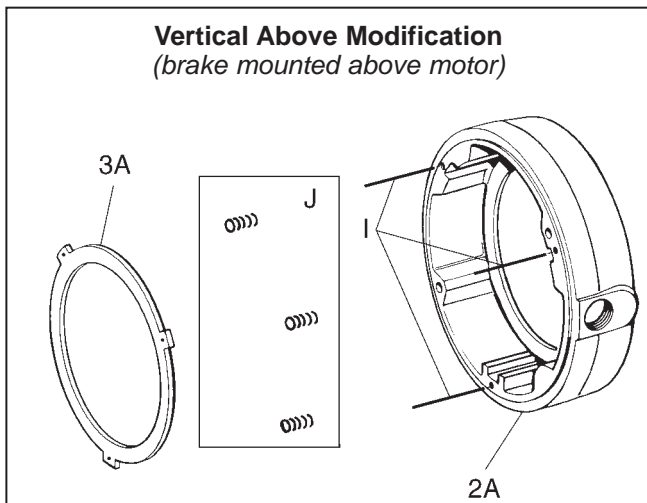
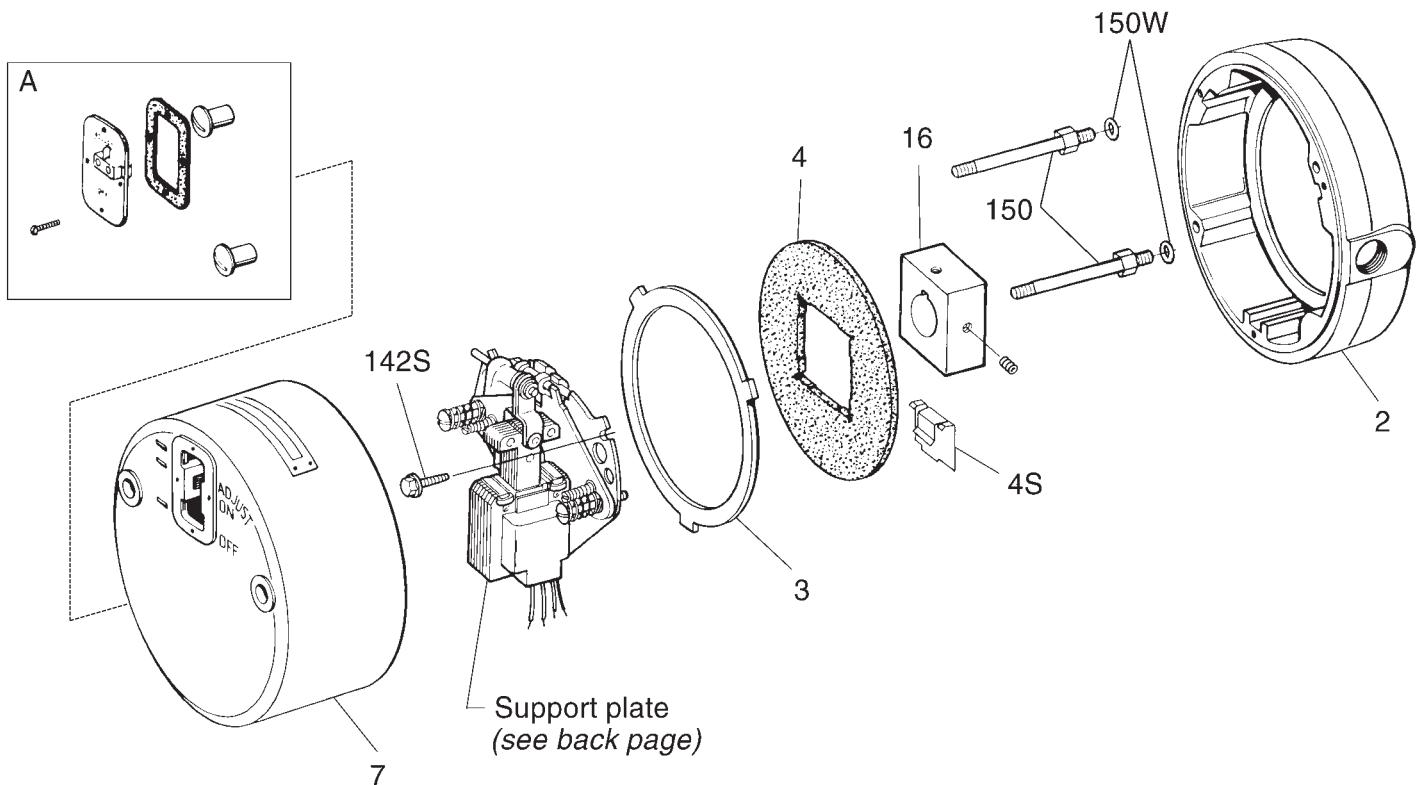

TABLE 1
Components of Standard AC or DC Brakes and Vertical Modifications

			Torque (lb-ft)		1.5 & 3		6		10		15		25	
			Current		AC	DC	AC	DC	AC	DC	AC	DC	AC	DC
			Enclosure		O	E	O	E	O	E	O	E	O	E
			Brake Model Number →		1-055-011-01 & 021-01		1-055-012-01 & 022-01		1-055-015-02 & 025-02		1-055-016-02 & 026-02		1-055-031-01	
					1-055-032-01		1-055-035-02		1-055-036-02		1-055-043-01		1-055-044-01	
					1-055-047-02		1-055-048-02		1-055-051-01		1-055-052-01		1-055-055-02	
					1-055-056-02		1-055-053-01		1-055-054-01		1-055-057-02		1-055-058-02	
Item	Description	Part Number ↓												
A	HARDWARE KIT - OPEN BRAKE HARDWARE KIT - DTWP BRAKE	5-66-1004-00 5-66-1005-00	1	1	1	1	1	1	1	1	1	1	1	1
7	Housing (<i>aluminum</i>) Housing (<i>aluminum</i>)	8-007-533-00 8-007-533-02	1	1	1	1	1	1	1	1	1	1	1	1
3	STATIONARY DISC KIT	5-66-8351-00	1	1	1	1	2	2	2	2	3	3	3	3
4	FRICITION DISC KIT	5-66-8452-00	1	1	1	1	2	2	2	2	3	3	3	3
4S	Stabilizing spring	8-161-501-00	2	2	2	2								
16	Hub and set screw assembly - 5/8" bore* Hub and set screw assembly - 7/8" bore* Hub and set screw assembly - 5/8" bore* Hub and set screw assembly - 7/8" bore* Hub and set screw assembly - 5/8" bore* Hub and set screw assembly - 7/8" bore* Hub and set screw assembly - 5/8" bore* Hub and set screw assembly - 7/8" bore*	5-16-5101-00-01B 5-16-5101-00-01D 5-16-5103-00-01B 5-16-5103-00-01D 5-16-5105-00-01B 5-16-5105-00-01D 5-16-5107-00-01B 5-16-5107-00-01D	1	1	1									
	Hub and set screw assembly } <i>specify bore size</i> Hub and set screw assembly } Hub and set screw assembly } Hub and set screw assembly }	5-16-5102-00 5-16-5104-00 5-16-5106-00 5-16-5108-00		1	1		1	1		1	1		1	1
2	Endplate Endplate Endplate Endplate and oil seal assembly Endplate and oil seal assembly Endplate and oil seal assembly	8-002-507-02 8-002-508-02 8-002-509-02 5-22-5001-00 5-22-5003-00 5-22-5005-00	1	1	1	1	1	1	1	1	1	1	1	1
150	Housing stud	8-150-505-00	2	2	2	2	2	2	2	2	2	2	2	2
150W	Lock washer	9-45-1328-00	2	2	2	2	2	2	2	2	2	2	2	2
Vertical Above Modification														
2A	Endplate and pin assembly Endplate and pin assembly Endplate and pin assembly Endplate, oil seal and pin assembly Endplate, oil seal and pin assembly Endplate, oil seal and pin assembly	5-20-5001-00 5-20-5002-00 5-20-5003-00 5-22-5002-00 5-22-5004-00 5-22-5006-00	-	-	-	-	1	1						
3A	STATIONARY DISC KIT - VERTICAL MTG.	5-66-8352-00	-	-	-	-	2	2	2	2	3	3	3	3
I	Vertical mounting pin Vertical mounting pin Vertical mounting pin	8-061-501-00 8-061-502-00 8-061-505-00	-	-	-	-	3	3	3	3	3	3	3	3
J	Vertical mounting spring kit - blue Vertical mounting spring kit - white Vertical mounting spring kit - red	5-66-3151-00 5-66-3152-00 5-66-3153-00	-	-	-	-	1	1	1	1	1	1	1	1
Vertical Below Modification														
3B	PRESSURE PLATE KIT - VERT. MTG. W/O PINS	5-66-8553-00	-	-	-	-	1	1	1	1	1	1	1	1
L	Vertical mounting pin Vertical mounting pin Vertical mounting pin	9-32-4070-00 9-32-4062-00 9-32-4071-00	-	-	-	-	3	3	3	3	3	3	3	3
3A	STATIONARY DISC KIT - VERTICAL MTG.	5-66-8352-00	-	-	-	-	1	1	1	1	2	2	2	2
J	Vertical mounting spring kit - blue Vertical mounting spring kit - white Vertical mounting spring kit - red	5-66-3151-00 5-66-3152-00 5-66-3153-00	-	-	-	-	1	1	1	1	1	1	1	1

*All bores have 3/16" x 3/32" keyway.

TABLE 2 – Components of Support Plate and Coil Assembly

Item	Description	Part Number	1.5 through 15 (lb-ft)	25 (lb-ft)	
<i>not shown</i>	Support plate assembly (Items M through Y and EA)	5-42-5502-00 5-42-5503-00	1	1	
6	Bearing	8-006-501-00	1	1	
8	Solenoid lever	8-008-504-01	1	1	
8R	Retaining ring	9-03-0057-00	2	2	
8W	Spacer	9-45-0168-00	3	3	
11N	Torque adjustment nut	9-40-3928-00	2	2	
10	Wear adjustment screw	8-100-501-00	2	2	
11	Pressure spring	9-70-1302-00	2		
	Pressure spring	9-70-1306-00		2	
17	Lever arm and stopnut assy.	5-17-5002-00	1	1	
26	Bearing pin	9-29-4826-00	1	1	
28	Wear indicator	8-028-502-00	1	1	
59	Release spring	9-70-0809-00	1	1	
126	Support plate and spring stud assembly	5-26-5013-00	1		
	Support plate and spring stud assembly	5-26-5014-00		1	
131	Pivot pin	9-29-4836-00	1	1	
142S	Mounting screws	9-25-7331-00	3	3	
29A	Plunger stop	8-094-504-00	1	1	
AC Brakes					
Z	NO. 4 SOLENOID KIT	5-66-5041-00	1	1	
12A	NO. 4 COIL KIT	115/230 Vac	5-66-6407-33	1	
		230/460 Vac	5-66-6409-33	1	
		115 Vac	5-66-6401-33	1	
		230 Vac	5-66-6402-33	1	
	NO. K4 COIL KIT	460 Vac	5-66-6404-33	1	
		575 Vac	5-66-6405-33	1	
		115/230 Vac	5-66-6457-33		1
		230/460 Vac	5-66-6459-33		1
	115 Vac	5-66-6451-33		1	
	230 Vac	5-66-6452-33		1	
	460 Vac	5-66-6454-33		1	
	474 Vac	5-66-6455-33		1	
CC	Interlock microswitch	5-57-5515-00	1	1	
DC Brakes					
12B	NO. 4 COIL ASSEMBLY	115 Vdc	5-96-6416-33	1	
		230 Vdc	5-96-6417-33	1	
	NO. K4 COIL ASSEMBLY	115 Vdc	5-96-6466-33		
		230 Vdc	5-96-6467-33		
157	ELECTRONIC DC SWITCH KIT	24/28 Vdc	5-57-5712-05	1	
		115 Vdc	5-57-5716-05	1	
		230 Vdc	5-57-5717-05	1	

TABLE 3 – Old Model Number Interchange Table

Torque (lb-ft)	Old Model Number	Current Model Numbers		
		Enclosure	AC	DC
1.5	HTC-52	standard DTWP	1-055-011-01 1-055-012-01	1-055-015-02 1-055-016-02
3	HTC-52A	standard DTWP	1-055-021-01 1-055-022-01	1-055-025-02 1-055-026-02
6	HTC-54	standard DTWP	1-055-031-01 1-055-032-01	1-055-035-02 1-055-036-02
9	HTC-56	standard DTWP	none none	none none
10	HTC-56A	standard DTWP	1-055-043-01 1-055-044-01	1-055-047-02 1-055-048-02
15	HTC-58	standard DTWP	1-055-051-01 1-055-052-01	1-055-055-02 1-055-056-02
25	HTC-58	standard DTWP	1-055-053-01 1-055-054-01	1-055-057-02 1-055-058-02

TABLE 4 – Contents of Kits and Assemblies (contents may vary)

Letter Designation	Kit Description
A	Hardware kit-standard brake (5-66-1004-00) 2 - Housing nuts 1 - Release cover with clip 1 - Release cover gasket
	Hardware kit-DTWP brake (5-66-1005-00) 1 - Endplate oil seal 1 - Drain plug 2 - Housing nuts 2 - Housing nut gaskets 1 - Release cover 4 - Release cover screws 1 - Release cover gasket 1 - Housing-to-endplate gasket
3	Stationary disc kit (5-66-8351-00) 1 - Stationary disc
4	Friction disc kit (5-66-8452-00) 1 - Friction disc
16	Hub and set screw assemblies (all types) - all bores (5-16-51XX-00) 1 - Brake hub 2 - Set screws
3A	Stationary disc kit - vertical mounting (5-66-8352-00) 1 - Stationary disc for vertical above or below mounting
J	Vertical mounting spring kit - blue (5-66-3151-00) 3 - Vertical mounting springs -blue
	Vertical mounting spring kit - white (5-66-3152-00) 3 - Vertical mounting springs - white
	Vertical mounting spring kit - red (5-66-3153-00) 3 - Vertical mounting springs - red
K	Pressure plate kit - vertical mounting (5-66-8553-00) 1 - Pressure plate - vertical below
Z	No. 4 solenoid kit (5-66-5041-00) 1 - Plunger 1 - Solenoid link 1 - Frame (including mounting bracket) 1 - Solenoid link cap screw 1 - Solenoid link nut 3 - Solenoid mounting screws
12A 12B	No. 4 and K4 coil kit (5-66-64XX-33) and assembly (5-96-64XX-33) - all voltages 1 - Coil 2 - Top plunger guide Wire nuts } where Crimp terminals } required
157	DC switch kit (5-57-57XX-05) 1 - Switch 1 - Mounting bracket 2 - Support plate mounting screws 2 - Switch mounting screws 2 - Nuts 3 - Crimp connectors
CC	Interlock microswitch (5-57-5515-00) 1 - Microswitch 1 - Mounting bracket 4 - Screws 2 - Lock washers 2 - Star washers 2 - Nuts

Support Plate Assembly

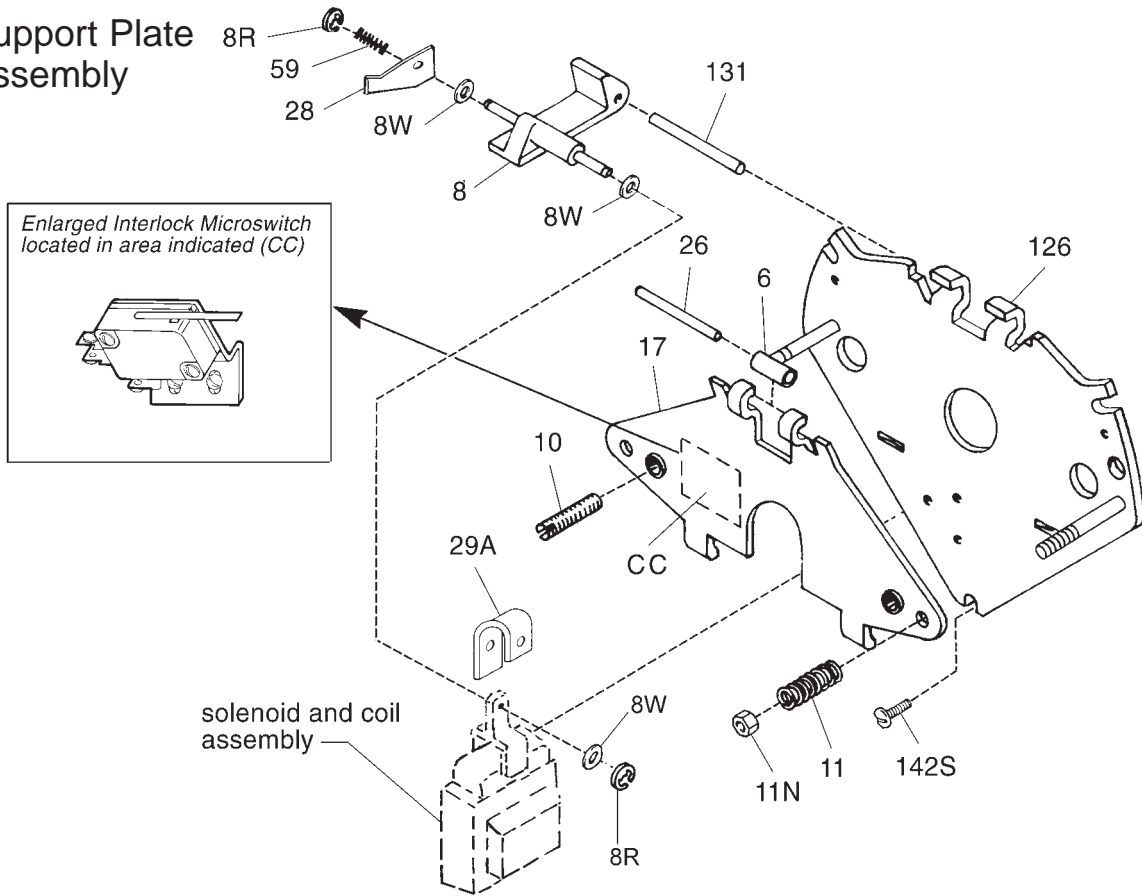

Solenoid and Coil Assembly

