

Parts List for 55,700 Double C-Face Coupler

With 1985 design brake shaft (35) and hub (16) coupled to motor shaft.

Information required when ordering replacement parts:

- Give part number of parts or kits needed, brake model number, and brake serial number. The brake model and serial number may identify special brakes not covered by this parts list.
- When ordering hubs, specify shaft diameter (hub bore) and keyway.
- Enclosures are designed as follows:
 O = Standard
 E = Dust-tight, waterproof (DTWP)

For installation and service instructions see P/N 8-078-925-07.
Detailed service instruction sheet is included with each kit.

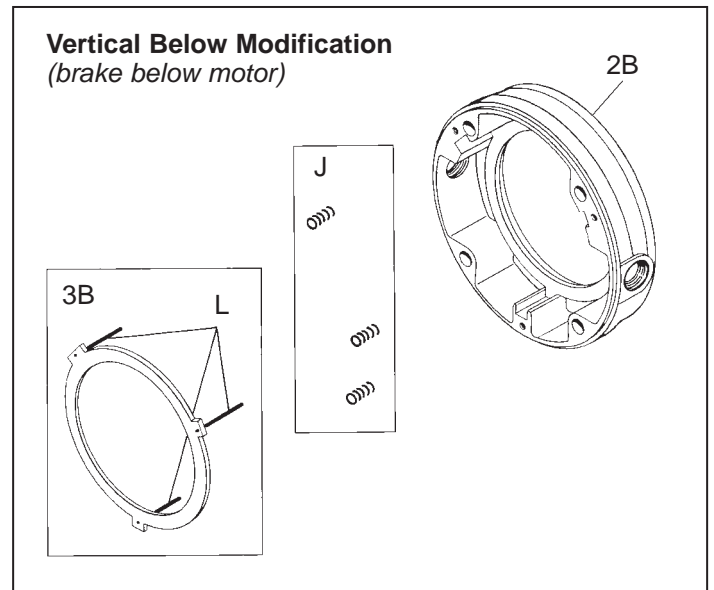
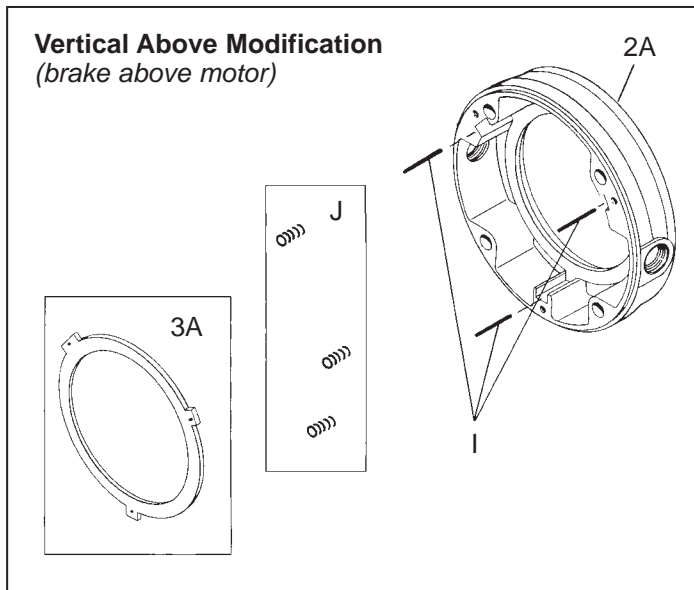
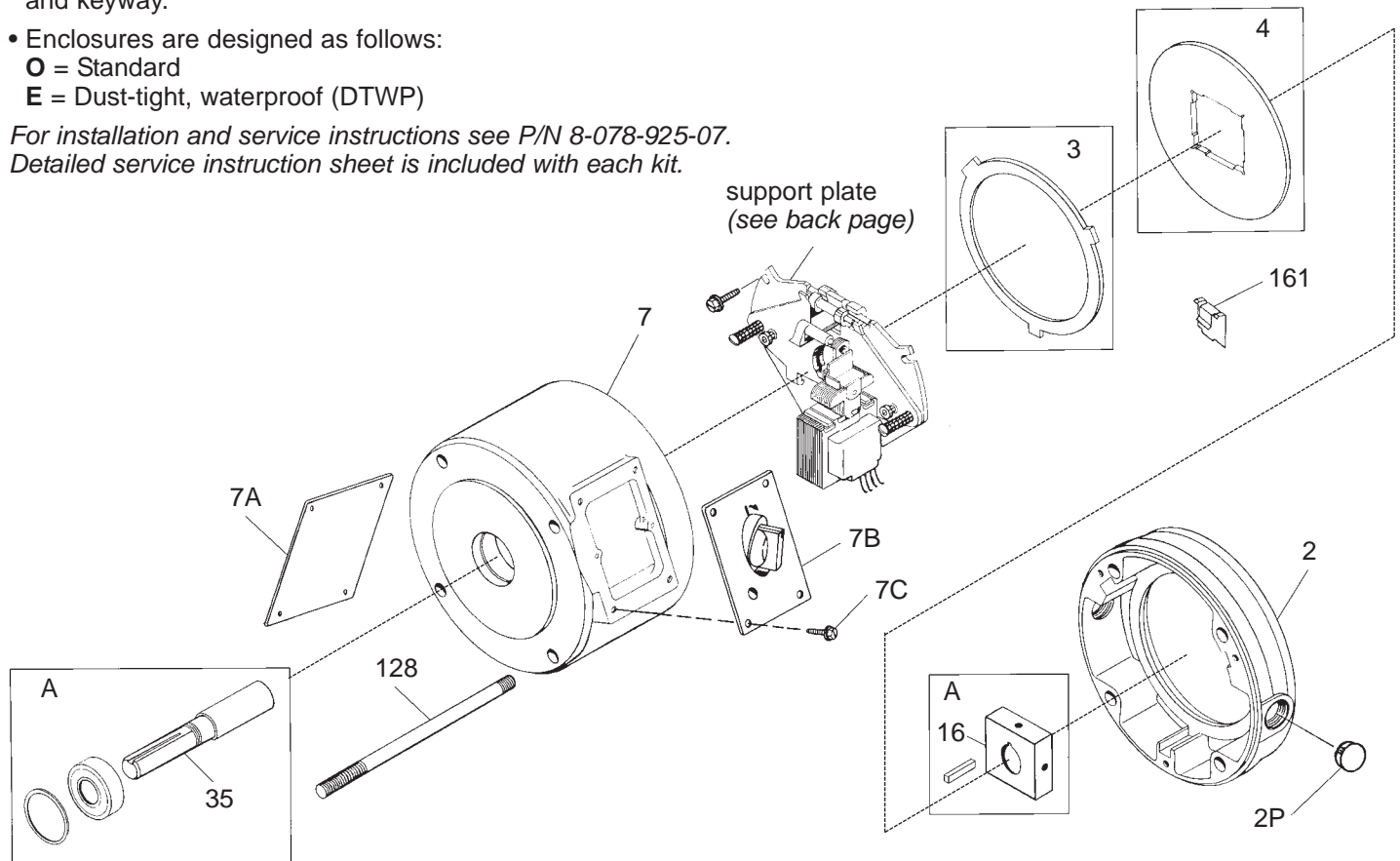

Support Plate Assembly

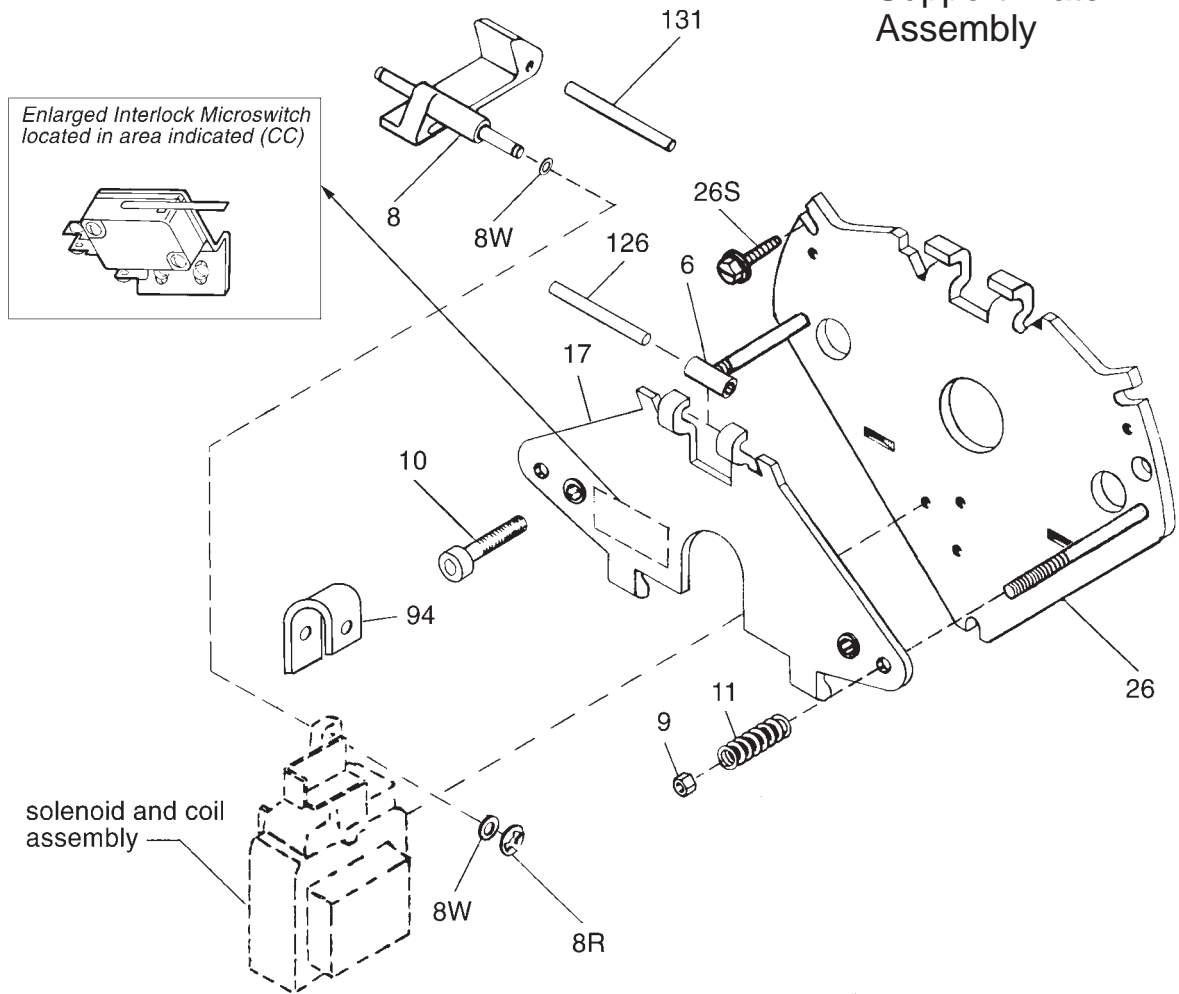
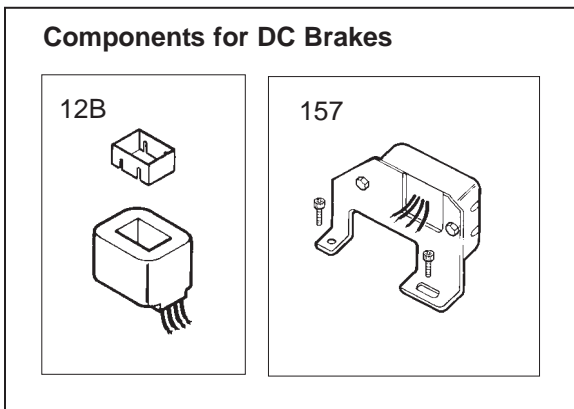
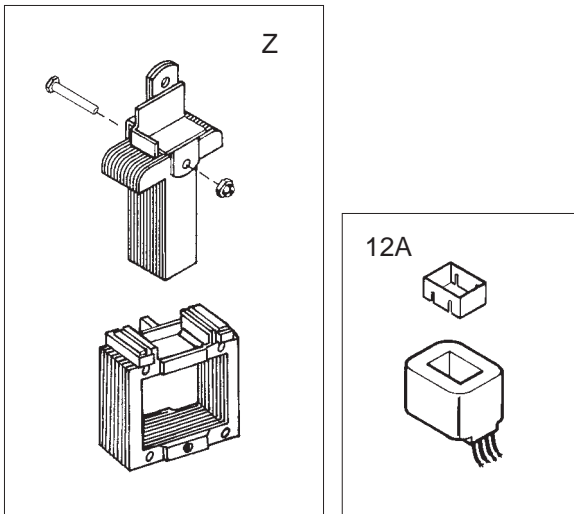

TABLE 3 - Components of Support Plate and Coil Assembly

Item	Description	Part Number	Torque (lb-ft)		
			1.5-3	6-10	15
<i>not shown</i>	Support plate assembly	5-42-5571-00	1		
<i>not shown</i>	Support plate assembly	5-42-5572-00		1	
<i>not shown</i>	Support plate assembly	5-42-5573-00			1
6	Bearing	8-006-501-00	1	1	1
8	Solenoid lever	8-008-504-01	1	1	1
8R	Retaining ring	9-03-0057-00	1	1	1
8W	Spacer	9-45-0168-00	2	2	2
9	Torque adjustment nut	9-40-3928-00	2	2	2
10	Wear adjustment screw	9-17-8420-00	2	2	2
11	Pressure spring	9-70-1210-00	2		
	Pressure spring	9-70-1302-00		2	
	Pressure spring	9-70-1306-00			2
17	Lever arm & stop nut assy.	5-17-5002-00	1	1	1
126	Bearing pin	9-29-4826-00	1	1	1
94	Plunger stop	8-094-503-00	1	1	1
26	Support plate and spring stud assembly	5-26-5017-00	1	1	
	Support plate and spring stud assembly	5-26-5018-00			1
26S	Screw - thread roll 10-24 x 1/2"	9-25-7331-00	3	3	3
131	Pivot pin	9-29-4836-00	1	1	1

Item	Description	Part Number	Torque (lb-ft)		
			1.5-3	6-10	15
AC Brakes					
Z	No. 4 solenoid kit	5-12-5547-00	1	1	1
AA	No. 4 coil kit	115/230 Vac	5-66-6407-33	1	1
		230/460 Vac	5-66-6409-33	1	1
		115 Vac	5-66-6401-33	1	1
		230 Vac	5-66-6402-33	1	1
		460 Vac	5-66-6404-33	1	1
		575 Vac	5-66-6405-33	1	1
	No. K4 coil kit	115/230 Vac	5-66-6457-33		1
		230/460 Vac	5-66-6459-33		1
		115 Vac	5-66-6451-33		1
		230 Vac	5-66-6452-33		1
		460 Vac	5-66-6454-33		1
		575 Vac	5-66-6455-33		1
CC	Interlock microswitch	5-57-5515-00	1	1	1
DC Brakes					
AB	No. 4 coil assembly	115 Vdc	5-96-6416-33	1	1
		230 Vdc	5-96-6417-33	1	1
	No. K4 coil assembly	115 Vdc	5-96-6466-33		1
		230 Vdc	5-96-6467-33		1
BB	Electronic DC switch kit	24/28 Vdc	5-57-5712-05	1	1
		115 Vdc	5-57-5716-05	1	1
		230 Vdc	5-57-5717-05	1	1

Solenoid and Coil Assembly



Manual Release Kits

(for standard open brakes only)

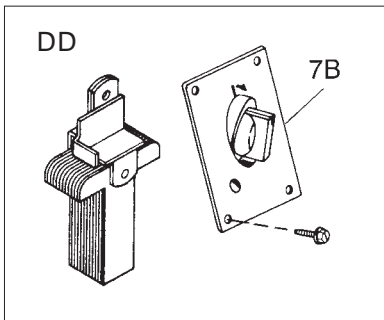

TABLE 4 - Contents of Kits and Assemblies
(contents may vary)

Letter Designation	Kit Description
A	Coupler brake shaft kit 5/8" shaft (5-66-8855-01) 7/8" shaft (5-66-8857-01) 1 - Hub and set screw assembly 1 - Ball bearing 1 - Housing retaining ring 1 - Brake shaft 1 - Brake shaft key
3	Stationary disc kit (5-66-8351-00) 1 - Stationary disc
4	Friction disc kit (5-66-8452-00) Friction disc
3A	Stationary disc kit - vertical mounting (5-66-8352-00) 1 - Stationary disc for vertical above or below mounting
J	Vertical mounting spring kit - blue (5-66-3151-00) 3 - Vertical mounting springs - blue Vertical mounting spring kit - white (5-66-3152-00) 3 - Vertical mounting springs - white
3B	Pressure plate kit - vertical mounting (5-66-8553-00) 1 - Pressure plate - vertical below
Z	No. 4 solenoid kit (5-12-5547-00) 1 - Plunger 1 - Solenoid link 1 - Frame (including mounting bracket) 1 - Solenoid link cap screw 1 - Solenoid link nut 3 - Solenoid mounting screws
12A 12B	No. 4 and K4 coil kit (5-66-64XX-33) and assembly (5-96-64XX-33) – all voltages Coil Top plunger guide Wire nuts } where Crimp terminals } required
157	DC switch kit (5-57-57XX-05) 1 - Switch 1 - Mounting bracket 2 - Support plate mounting screws 2 - Switch mounting screws 2 - Nuts 3 - Crimp connectors
CC	Interlock microswitch (5-57-5515-00) 1 - Microswitch 1 - Mounting bracket 4 - Screws 2 - Lock washers 2 - Star washers 2 - Nuts
Manual Release Kits	
DD	Standard open brakes (5-55-5001-00)