

Installation, Service and Parts List for 82,300 Series Brakes

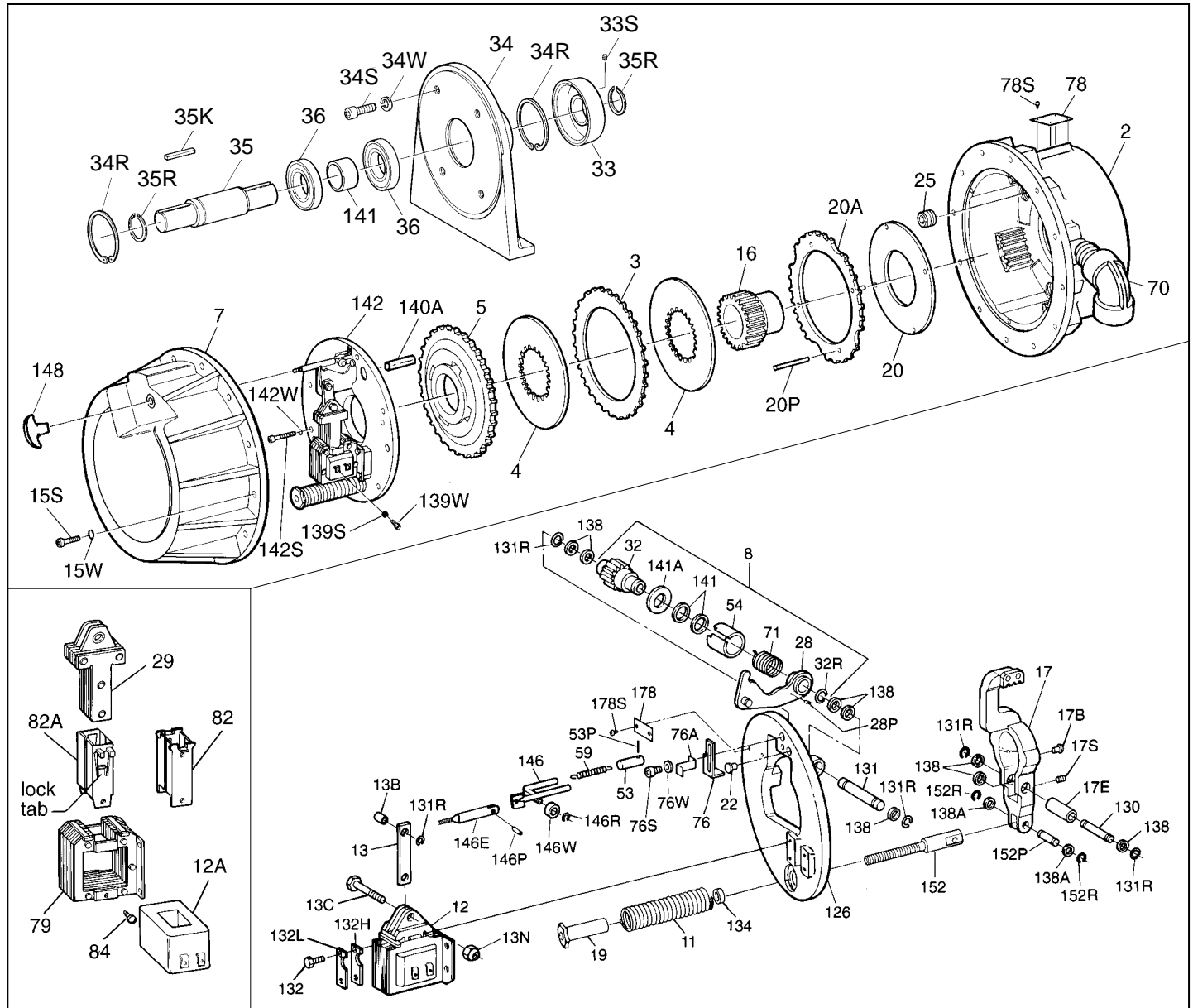

Figure 1

Important

Please read these instructions carefully before installing, operating, or servicing your Stearns brake. Failure to comply with these instructions could cause injury to personnel and/or damage to property if the brake is installed or operated incorrectly. For definition of limited warranty/ liability, contact Rexnord Industries, Inc., Stearns Division, 5150 S. International Dr., Cudahy, WI 53110, (414) 272-1100.

Caution

1. Installation and servicing must be made in compliance with applicable local safety codes including Occupational Safety and Health Act (OSHA). All wiring and electrical connections must comply with

the National Electric Code (NEC) and local electric codes in effect.

2. Do not install brake in a hazardous location other than that as designated on the U.L. label.
3. To prevent an electrical hazard, disconnect power source before working on the brake. If power disconnect point is out of sight, lock disconnect in the *off* position and tag to prevent accidental application of power.
4. Be careful when touching the exterior of an operating brake. Allow sufficient time for brake to cool before disassembly. Surfaces may be hot enough to be painful or cause injury.
5. Do not operate brake with housing

removed. All moving parts should be guarded.

6. Installation and servicing should be performed only by qualified personnel familiar with the construction and operation of the brake.
7. For proper performance and operation, only genuine Stearns parts should be used for repairs and replacements.
8. After usage, the brake interior will contain burnt and degraded friction material dust. This dust must be removed before servicing or adjusting the brake.
DO NOT BLOW OFF DUST using an air hose. It is important to avoid dispersing dust into the air or inhaling it, as this may be dangerous to your health.

- a) Wear a filtered mask or a respirator while removing dust from the inside of a brake.
- b) Use a vacuum cleaner or a soft brush to remove dust from the brake. When brushing, avoid causing the dust to become airborne. Collect the dust in a container, such as a bag, which can be sealed off.

General Description

Stearns Series 82,300 is a spring-set, magnetically released disc brake. The brake is listed by Underwriters Laboratories, Inc. for Class I, Group C and D, and Class II, Group E and F hazardous locations. The listing includes two types of brakes, one for attachment to a listed motor at that motor manufacturer's factory and the other type which is complete by mounting on a common base and coupling to a motor. The listing marks on the brake apply only to the brake, not to the driving equipment. In the case of a motor mounted brake neither brake nor motor are listed unless both are listed. The listing marks of both the brake and the motor must be in agreement as to the Class and Group rating.

The brake is essentially designed for holding purposes but may be used for stopping light inertia loads. The actuating mechanism includes a self-adjust feature to compensate for wear of the friction linings or for thermal expansion. The brake has a single-phase solenoid coil for operation on alternating current only. The nominal static torque is factory set. The brake is not waterproof or dust-tight and protection from the weather and other conditions is required.

Standard AC NEMA Class A voltages are available. Direct current coils are not available.

Operation

Each brake assembly consists of two or three molded friction discs fitted over a splined end of a hub attached to or driven by a motor shaft. The friction discs are located alternately between an endplate, stationary disc(s) and a pressure plate. The stationary disc(s) and pressure plate are restrained from rotating through splines in the endplate. A solenoid, lever system, and a pressure spring are located on a support plate. A fitted housing, attached to the endplate, encloses the working parts. The housing also provides location and support for a manual release lever.

The release of the brake occurs when the solenoid coil is energized causing the solenoid plunger to travel a specified distance and, through the lever system, overcome the pressure spring force. The lever system in its travel disengages from the pressure plate which permits the friction discs to rotate when the motor is energized. When the motor and solenoid coil are de-energized the pressure spring moves the lever system toward the pressure plate, applying a force to stop the rotation of the friction discs.

The brake is equipped with a manual release lever, which, when activated, sufficiently releases the brake without energizing the solenoid coil, permitting manual movement of the drive system. When the solenoid is energized the manual

release lever returns to its initial position and permits the brake to set when the solenoid coil is again de-energized.

Note: The motor should not be run with the brake in the manual release position to avoid overheating of friction discs.

I. Installation Procedure (See Figure 1)

Note 1: For optimum results, position brake so that solenoid plunger (29) is above the frame (79) when installed. The brake may be mounted horizontally with the solenoid plunger above the frame, or if specifically modified, vertically above or vertically below the motor.

If motor is to be wall or ceiling mounted, brake must be oriented so that brake plunger is above frame when motor is installed.

Note 2: The motor mounted brake should be mounted on a C-face surface. The face run out should be within .007 T.I.R. The eccentricity of the mounting rabbet should be within .007 T.I.R. The shaft run out should be within .003 T.I.R.

Method I motor mounted brake

1. Unscrew manual release knob (148), housing screws and washers (15S and 15W) and remove housing (7).
2. Depress solenoid plunger and pull release rod (146) back to lock brake mechanism in manual release position.
3. Disconnect solenoid coil lead wires at solenoid. If brake is supplied with heater it will be necessary to loosen heater clamp (not shown) in order to slide heater through support plate.
4. Remove entire support plate assembly (142) by evenly unscrewing and removing screws and lock washers (142S and 142W).
5. Remove pressure plate (5), friction discs (4) and stationary disc(s) (3).

Note: Vertically mounted brakes will have special pins which guide spacer springs and, in some cases, spring washers. Note color coded sequence of spring and location of washers, if used.

See *Installation*, Note 1.

6. Attach endplate assembly (2) to mounting face of motor using four socket head cap screws and lock washers (not supplied). Insert set screw mounting bolt (25) over socket head cap screws. (Head of set screw mounting bolts must not project above friction surface.)
7. Position hub (16) and key (not supplied) on the motor shaft so that face of hub will protrude approximately 1/8" beyond the face of the last outboard friction disc. (Position may be determined by assembling friction discs and stationary disc(s) onto hub, noting hub position, and removing discs.) Tighten two hub set screws (16S). Torque set screws as follows:

5/16 diameter 165 in-lb
 3/8 diameter 290 in-lb
 1/2 diameter 620 in-lb

Note: A small diametrical clearance is maintained between the cylindrical portion of the hub and the inside diameter of the endplate. Hub should be free to rotate

without binding or interference. Hub should not be touching or interfering with the heat barrier (20).

8. Assemble friction discs and stationary disc(s) alternately. Pressure plate completes disc pack assembly. If vertical style, replace springs, etc.

Note: Friction discs should be free to slide on hub and the stationary disc(s) and pressure plate should be free to slide in endplate.

9. Mount support plate assembly drawing screws down evenly. Be sure the assembly is mounted with the solenoid plunger above the solenoid frame on horizontally installed brakes. (See *Installation*, Note 1.)
10. Disengage manual release lever by depressing plunger sufficiently to allow release rod to retract.

Note: If release rod is not in manual release position and has allowed the mechanism to overadjust and the support plate will not seat against the endplate, it will have to be reset. In this case the lever arm (17) throat will be near, or touching, the pinion (32) teeth. Loosen pressure spring nut (19) until pressure spring (11) is free. Mount support plate and retighten spring nut. Lift plunger to maximum travel and release.

11. Manually depress solenoid plunger into the solenoid frame and release. Repeat this process several times to set solenoid air gap. (Check *Self-Adjust Maintenance* Section for proper air gap measurement or corrective action for loss of gap.)
12. Replace and/or remake connections on all internal electrical hardware. (See Section on *Electrical Connection of Brake*.)
13. Complete external electrical connections. (See Section on *Electrical Connection of Brake*.)
14. Check that friction discs rotate freely when the solenoid plunger is held firmly against the solenoid frame. If binding or sticking occurs recheck Steps 6, 7 & 8.
15. Replace housing, screws and lock washers. Torque screws to 298 in-lbs. Replace manual release knob.

Note: Since a small diametrical clearance exists between the housing and the endplate, care must be taken that this clearance is maintained. Diameters and surfaces must be free of burrs, nicks, and dirt to insure a proper fit.

Method II floor mounted brake

1. The floor mounted brake is factory set and ready to install. Note 1 of *Installation Instructions* applies to floor mounted brakes as well as motor mounted brakes.
2. Couple brake directly to output shaft of the drive system. Alignment of the shafts must be within the recommended limits as specified by the coupling manufacturer. The use of dowels is recommended to insure permanent alignment. Do not subject brake shaft (35) to overhung loads.
3. Continue at Step 11.

II. Electrical Connection of Brake

CAUTION: Inverter Motor and Special Control Systems. This brake contains either a single phase AC coil or DC coil that requires instantaneous power within – 10% of rating at the coil. A separate power source is required when this brake is used in conjunction with a motor or control system that limits voltage or current input (i.e. inverter motors) or causes a ramping of the power supply.

Note 1: Brake coil connections described here cover common motor connections. For nonstandard motors or control connections, contact respective supplier or Stearns Division.

Note 2: On brakes with space heater, connect to appropriate power source. Heater is to be energized continuously, including storage periods, if rust may occur.

Note 3: See Figure 4 for proper connections of protector switch TSW2, optional warning switch TSW1, optional heater and optional microswitches.

The Series 82,300 Brake is equipped with an AC single-phase coil. Connect single voltage coil to any two leads on single or three-phase motor of the same voltage as the brake. Refer to brake nameplate and coil number for correct voltage and frequency. The brake can also be wired to external switch contacts providing proper voltage other than that used to control the motor. Normally, the motor and brake contacts are interlocked.

Dual voltage coil connection

Preconnect as shown in Figure 2. On these coils observe the lead numbering sequence for proper connections as follows:

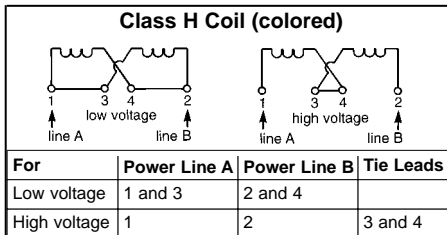

Figure 2

Connecting AC solenoid coils to dual voltage 230/460 three-phase motors

To use a 230 volt coil with a 230/460 dual voltage, three-phase motor, brake leads are connected across two motor terminals as shown in Figure 3, or two equivalent combinations. Brake will operate on 230 volts whether motor is connected for 230 or 460 volts.

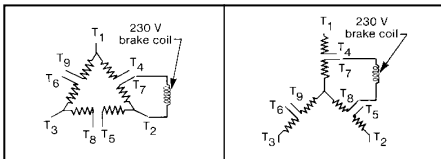

Figure 3

III. General Maintenance

Warning! Any mechanism or load held in position by the brake should be secured to prevent possible injury or damage to equipment before any disassembly of the brake is attempted or the manual release

knob or lever is operated on the brake.

A. Coil replacement

1. Disconnect power source from brake and lock out.
2. Unscrew manual release knob, housing screws and washers, and remove housing.
3. Disconnect coil (12) from circuit.
4. Remove solenoid link screw (13C), retaining ring (131R), solenoid link (13) and lift plunger (29) from frame (79).
5. For metallic plunger guides (82) remove plunger guide screw(s) (84) and lock washer(s) (84W). Remove both plunger guides (82) by prying up on the flanges. Discard plunger guides if worn or cracked.
 - a) To remove non-metallic plunger guides (82A) remove screw(s) (84) and insert shim stock or other thin gauge material at top center of coil between coil and solenoid frame. Push to release lock tab while lifting up on plunger guide. Repeat for other plunger guide.
6. Slide coil (12A) out from solenoid frame (79) in the direction of the terminals. If necessary, tap coil lightly with a soft hammer. If solenoid coil had burned out, be sure to remove all foreign material from the solenoid plunger (29) and solenoid frame.
7. Install new coil (12A) into solenoid frame with same relative position as old coil. Assemble new metallic plunger guides (82), plunger guide screw(s) (84) and lock washer(s) (84W) if used.
 - a) Assemble new non-metallic plunger guides (82A) by inserting into position and pushing down until lock tab snaps under top bar of solenoid frame.

Note: Check that lock face is flush with inside surface of guide. If not, file chamfer (about 1/16 by 45) on coil at lock tab area.

 Install plunger guide screw(s) (84) and lock washers (84W).
8. Reinstall material removed at Step 4. Depress solenoid plunger and release as in Step 11 of the *Installation Procedure*, Method I.

- a) Assemble new non-metallic plunger guides (82A) by inserting into position and pushing down until lock tab snaps under top bar of solenoid frame.

Note: Check that lock face is flush with inside surface of guide. If not, file chamfer (about 1/16 by 45) on coil at lock tab area.

 Install plunger guide screw(s) (84) and lock washers (84W).

8. Reinstall material removed at Step 4. Depress solenoid plunger and release as in Step 11 of the *Installation Procedure*, Method I.

B. Renewal of friction discs

1. Disconnect power source from brake and lock out.
2. Follow Steps 1 through 5 of the *Installation Procedure*, Method I.
3. Follow Steps 8 through 15 of the *Installation Procedure*, Method I.

C. Renewal of heat barrier and insulator disc

1. Disconnect power source from brake and lock out.

WARNING - The thermostats (mounted in this brake must be wired into control circuit to limit the brake external surface temperature.

Note For Dual Voltage Connection Only. Solenoid coil is factory wired for high voltage. Black coil leads 1 and 2, only coil leads extending outside of brake enclosure, always connects to power. For lower rated voltage connection, rewire coil internally per dual voltage diagram on solenoid frame.

Warning device TSW1 indicates the approach of an abnormal high temperature condition. The duty cycle should be reduced when TSW1 closes activating the warning device electrical circuit, and indicating an abnormally hot condition. If the warning is not needed and the temperature continues to rise, switch TSW2 will open the motor circuit and cause the brake to set. In moist atmospheres a heater is recommended and should be energized whenever the brake is set.

Two purple lead wires are provided for each microswitch, (SW1 - for brake release and SW2 - for maximum wear indicator). Lead wires are factory wired to N.O. microswitch contacts. Customer may reconnect to N.C. contacts if so desired.

| Ratings Vac | | | |
|-------------|------|-------|------|
| TSW1 | | TSW2 | |
| Volts | Amps | Volts | Amps |
| 575 | 1.25 | 575 | 1.25 |
| 460 | 1.56 | 460 | 1.56 |
| 230 | 3.13 | 230 | 3.13 |
| 120 | 6.00 | 120 | 6.00 |

| Ratings Vac Optional Heater | |
|--------------------------------|-------|
| Volts | Watts |
| 120 | 50 |
| 240 | 50 |

| Ratings for Optional Microswitches | |
|---------------------------------------|---------|
| Voltage | Current |
| 240 Vac | 15A |
| 115 Vdc | .5A |

Typical Connection Diagram

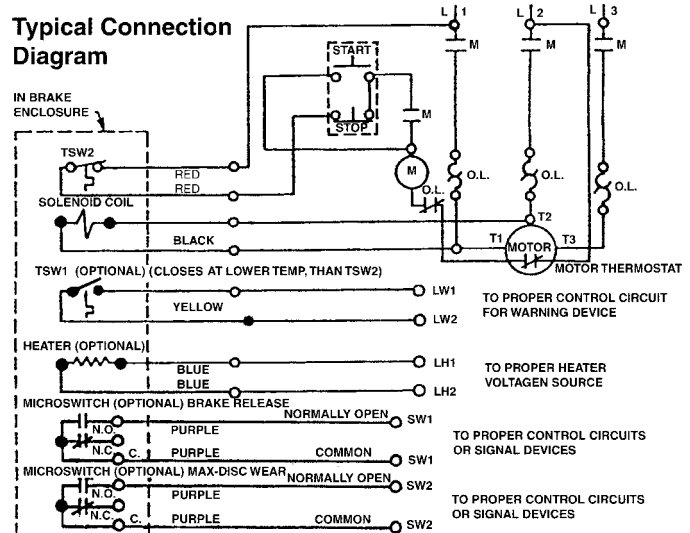

Figure 4

2. Follow Steps 1 through 5 of the *Installation Procedure*, Method I, and remove hub.
3. Using a suitable pry bar (a standard 5/16 hexagon key, for instance) pry evenly around insulator disc (20A) until free of spiro pins (20P) and lift out.
4. Remove spiro pins. (Gripping with suitable pliers pull and twist until pins are free.)
5. Remove heat barrier (20) and clean all surfaces as required.
6. Position new heat barrier and insulator disc. Be sure holes for spiro pins line up with holes in endplate and notches in insulator disc clear set screw mounting bolts.
7. Install spiro pins using a large diameter flat punch to drive pins until flush with surface of insulator disc. Using a smaller diameter punch drive pins until seated against insulator disc.
8. Follow Steps 8 through 15 of the *Installation Procedure*, Method I.

D. Bearing replacement (floor mounted brake)

1. Disconnect power source from brake and lock out.
2. Follow Steps 1 through 5 of the *Installation Procedure* for motor mounted brake, Method I.
3. Reverse Steps 7 and 6 of the *Installation Procedure*, Method I to remove hub and endplate.
4. Remove retaining ring (35R) from brake shaft (35) located outboard of floor stand collar (33). Remove collar by loosening set screws (33S) and sliding collar off.
5. Remove large diameter retaining rings (34R).
6. Press bearings out of floor stand (34).
7. Remove retaining ring (35R) from brake shaft and press shaft out of bearings and bearing spacer (141).
8. Clean shaft and floor stand as required.
9. Replace retaining ring on inboard end (end with longest space between shoulder and retaining ring groove) of shaft. Pressing on inner race of bearings install new bearings and bearing spacer in same order as removed. Retaining ring will serve as a stop.
10. Replace inboard retaining ring in floor stand and by pressing on outer race of bearing install bearing and shaft assembly into floor stand.
11. Complete installation by reversing Steps 5 and 4 of this procedure.
12. Reassemble brake to floor stand following *Installation Procedure*, Method I, for the motor mounted brake.

E. Self-adjust maintenance

The solenoid is factory set with a 1-3/8 to 1-7/16 air gap, and requires no resetting, even when changing friction discs. The air gap is determined by the position of the wrap spring stop (76). Due to *wear-in* of parts the normal operating gap is 1-5/16 to 1-1/2 .

Note: To measure solenoid air gap on vertically mounted brakes grasp solenoid link to hold plunger in a free horizontal position, and move toward solenoid frame

until spring pressure is felt. Holding firmly in this position measure air gap between mating (ground) surfaces on solenoid frame and solenoid plunger.

Should gap have changed, inspect position of the wrap spring stop and adjust air gap as follows:

1. Tang of wrap spring (71) must be below and must make contact with wrap spring stop when solenoid lever (28) is manually lifted to a maximum position. If wrap spring stop is bent outward, allowing tang to bypass it, rebend to a square position and assemble correctly.
2. The air gap is measured between mating surfaces of plunger and solenoid frame. To set air gap, loosen spring stop cap screw (76S). Raise wrap spring stop to its maximum position and retighten cap screws slightly. Lift solenoid plunger to its maximum position and release. Gently tap the wrap spring stop down toward the solenoid frame. Continue until air gap is between 1-3/8 and 1-7/16 . Retighten cap screws. Depress plunger manually or electrically into the solenoid frame and allow it to snap back. Repeat several times, then recheck air gap. To increase air gap raise wrap spring stop slightly and to decrease air gap lower wrap spring stop slightly. After every adjustment depress and release plunger several times, as above, before rechecking air gap.

Should air gap have disappeared, oil or other lubrication may have contaminated the solenoid lever and pinion assembly (8) requiring cleaning. Remove support plate assembly following Steps 3 and 4 of *Installation Procedure*, Method I. Loosen pressure spring nut (19) until pressure spring (11) is free. Remove retaining rings (131R) from solenoid lever pivot pin (131). Note sequence of washer type bearings (138) and push pivot pin out to free assembly. Remove retaining ring (32R) from assembly and remove pinion (32) by rotating as it is pulled out. Remove sleeve (54). Remove wrap spring from solenoid lever by gently pulling and rotating. Parts should be thoroughly cleaned in a clean solvent M.E.K. or equivalent that does not leave a film. Dry all parts thoroughly and reassemble. Be sure wrap spring is tightly against side face of solenoid lever and the end of the last turn touches, without preload, spiro pin (28P). Spiro pin should protrude into solenoid lever for no more than the width of this turn.

Check condition and position of pinion and rack (part of lever arm assembly [17]). If pinion shows excessive wear, replace entire solenoid lever and pinion assembly (8) following above procedure. If rack shows excessive wear, remove and replace lever arm assembly as follows:

- a) Loosen pressure spring nut until pressure spring is free. Remove nut, spring and pressure spring spacer (134).
- b) Remove retaining ring (152R) and washer type bearing (138A) from spring stud pivot pin (152P) and remove pin and spring stud (152).
- c) Remove retaining ring (131R), bearing type washers (138), pivot pin (130) and

lever arm (17). Remove two set screws (17S) and eccentric sleeve (17E) from lever arm.

- d) Install new lever arm following Steps c and b in reverse order. Do not tighten pressure spring nut, but snug the two set screws (17S) of eccentric sleeve (17E) with hole in line with set screws.

Upon completion of installation of new lever arm it will be necessary to check and/or adjust the backlash between the rack and pinion.

- a) The backlash at either end of the rack should not exceed .003 and the movement of the rack over the pinion should be smooth and free of binding. Check as follows:
 - b) Lift solenoid plunger to its maximum position and advance lever arm forward toward the pinion. Position the lever arm so the first two teeth of the rack will be engaged with one tooth of the pinion when the plunger is resealed against the solenoid frame. The one tooth of the pinion should be over the centerline of the solenoid lever pivot pin.
 - c) Holding the plunger in the seated position move lever arm back and forth and determine backlash.
 - d) Lift plunger to its maximum position and advance lever arm until the last two teeth of the rack are engaged with one tooth of the pinion, when the plunger is resealed against the solenoid frame. The one tooth of the pinion should be over the centerline of the solenoid lever pivot pin.
 - e) Holding the plunger in the seated position move lever arm back and forth and determine backlash.
 - f) To adjust backlash loosen lever arm set screws (17S). To reduce backlash rotate lever arm eccentric sleeve (17E) counterclockwise. To increase backlash rotate eccentric sleeve clockwise.
 - g) After backlash adjustment has been completed, tighten lever arm set screws to 87 in-lbs torque.

Do not tighten spring nut until support plate assembly is mounted on the endplate. Follow Steps 8 through 13 of the *Installation Procedure*, Method I. Adjust solenoid air gap following Step 2 of *Self-Adjust Maintenance*, Section III-E. Complete assembly of brake by following Steps 14 through 15 of *Installation Procedure*, Method I.

IV. Troubleshooting

A. If brake does not stop properly, coasts, or overheats:

1. Check that manual release knob is not jammed in released mode.
2. Check for excessively worn, charred or broken friction discs.
3. Check that hub has not loosened and shifted on motor shaft or stud shaft (35) on floor mounted brake.
4. Check that friction discs slide freely over hub. Clean hub and/or file burrs and nicks if required.
5. Check that stationary disc(s) and/or

TABLE 1
Components of Motor Mounted and Floor Mounted Brakes

| Item No. | Description | Part Number ↓ | Style | | | | Motor Mounted | | | | Floor Mounted | | | |
|----------|--|------------------|----------------------|----|----|----|---------------|--------------|--------------|--------------|---------------|--------------|--------------|--------------|
| | | | Torque (lb-ft) | | | | 125 | 175 | 230 | 330 | 125 | 175 | 230 | 330 |
| | | | Brake Model Number → | | | | 1-082-311-00 | 1-082-321-00 | 1-082-331-00 | 1-082-341-00 | 1-082-312-00 | 1-082-322-00 | 1-082-332-00 | 1-082-342-00 |
| 2 | Endplate assembly (includes 20, 20A, 20P and 70) (consult factory) | 5-50-1001-00 | 1 | 1 | 1 | 1 | 1 | 1 | 1 | 1 | 1 | 1 | 1 | |
| 3 | Stationary disc | 8-003-105-01 | 1 | 1 | 2 | 2 | 1 | 1 | 2 | 2 | 2 | 2 | 2 | |
| 4 | Friction disc | 8-004-104-00 | 2 | 2 | 3 | 3 | 2 | 2 | 2 | 2 | 3 | 3 | 3 | |
| 4A | Carrier disc (horizontal only) | 5-18-1001-00 | | | | | | | | | | | | |
| 5 | Pressure plate | 8-005-107-01 | 1 | 1 | | | 1 | 1 | | | | | | |
| | Pressure plate | 8-005-108-01 | | | 1 | 1 | | | | | 1 | 1 | | |
| 7 | Housing and release rod bushing assembly | 5-07-1001-00 | 1 | 1 | 1 | 1 | 1 | 1 | 1 | 1 | 1 | 1 | 1 | |
| 15S | Cap screw | 9-17-3224-00 | 12 | 12 | 12 | 12 | 12 | 12 | 12 | 12 | 12 | 12 | 12 | |
| 15W | Lock washer | 9-45-1332-00 | 12 | 12 | 12 | 12 | 12 | 12 | 12 | 12 | 12 | 12 | 12 | |
| 16 | Hub and set screw assembly | 5-16-1003-00 | 1 | 1 | | | | | | | | | | |
| | Hub and set screw assembly | 5-16-1003-00-03L | | | | | 1 | 1 | | | | | | |
| | Hub and set screw assembly | 5-16-1004-00 | | | 1 | 1 | | | | | | | | |
| | Hub and set screw assembly | 5-16-1004-00-03L | | | | | | | | | 1 | 1 | | |
| 20 | Heat barrier (component of Item 2) | 8-004-104-01 | 1 | 1 | 1 | 1 | 1 | 1 | 1 | 1 | 1 | 1 | 1 | |
| 20A | Insulator disc (component of Item 2) | 8-003-106-01 | 1 | 1 | 1 | 1 | 1 | 1 | 1 | 1 | 1 | 1 | 1 | |
| 20P | Spirol pin (component of Item 2) | 9-32-2004-00 | 4 | 4 | 4 | 4 | 4 | 4 | 4 | 4 | 4 | 4 | 4 | |
| 25 | Set screw mounting bolt | 8-025-101-00 | 4 | 4 | 4 | 4 | 4 | 4 | 4 | 4 | 4 | 4 | 4 | |
| 70 | 90 elbow (component of Item 2) | 9-33-3005-00 | 1 | 1 | 1 | 1 | 1 | 1 | 1 | 1 | 1 | 1 | 1 | |
| 139S | Machine screw | 9-13-3017-00 | 2 | 2 | 2 | 2 | 2 | 2 | 2 | 2 | 2 | 2 | 2 | |
| 139W | Lock washer | 9-45-0326-00 | 2 | 2 | 2 | 2 | 2 | 2 | 2 | 2 | 2 | 2 | 2 | |
| 140A | Lead wire bushing (support plate) | 8-140-003-02 | 1 | 1 | 1 | 1 | 1 | 1 | 1 | 1 | 1 | 1 | 1 | |
| 142 | Support plate assembly (less coil) | 5-42-1018-00 | 1 | | | | 1 | | | | | | | |
| | Support plate assembly (less coil) | 5-42-1019-00 | | 1 | | | | 1 | | | | | | |
| | Support plate assembly (less coil) | 5-42-1020-00 | | | 1 | | | | | 1 | | | | |
| | Support plate assembly (less coil) | 5-42-1021-00 | | | | 1 | | | | | | 1 | | |
| 142S | Cap screw | 9-17-5016-00 | 6 | 6 | 6 | 6 | 6 | 6 | 6 | 6 | 6 | 6 | 6 | |
| 142W | Conical spring washer, 1/4 I.D. x 9/16 O.D. | 9-46-0006-00 | 6 | 6 | 6 | 6 | 6 | 6 | 6 | 6 | 6 | 6 | 6 | |
| 148 | Release knob | 8-148-804-00 | 1 | 1 | 1 | 1 | 1 | 1 | 1 | 1 | 1 | 1 | 1 | |
| 149 | Lead wire clamp | 9-61-0010-00 | 1 | 1 | 1 | 1 | 1 | 1 | 1 | 1 | 1 | 1 | 1 | |
| 149S | Machine screw | 9-10-2806-00 | 1 | 1 | 1 | 1 | 1 | 1 | 1 | 1 | 1 | 1 | 1 | |
| 149W | Lock washer | 9-45-0328-00 | 1 | 1 | 1 | 1 | 1 | 1 | 1 | 1 | 1 | 1 | 1 | |
| 33 | Floor stand collar | 8-033-101-01 | | | | | | 1 | 1 | 1 | 1 | 1 | 1 | |
| 33S | Set screw | 9-20-1006-00 | | | | | | 2 | 2 | 2 | 2 | 2 | 2 | |
| 34 | Floor stand | 8-034-103-01 | | | | | | 1 | 1 | 1 | 1 | 1 | 1 | |
| 34R | Retaining ring | 9-03-0064-00 | | | | | | 2 | 2 | 2 | 2 | 2 | 2 | |
| 34S | Cap screw | 9-17-1624-00 | | | | | | 4 | 4 | 4 | 4 | 4 | 4 | |
| 34W | Lock washer | 9-45-0316-00 | | | | | | 4 | 4 | 4 | 4 | 4 | 4 | |
| 35 | Brake shaft | 8-035-101-00 | | | | | | 1 | 1 | | | | | |
| | Brake shaft | 8-035-102-00 | | | | | | | | | 1 | 1 | | |
| 35K | Key (brake shaft) | 9-50-1840-00 | | | | | | 1 | 1 | | | | | |
| | Key (brake shaft) | 9-50-1848-00 | | | | | | | | | 1 | 1 | | |
| 35R | Retaining ring | 9-03-0037-00 | | | | | | 2 | 2 | 2 | 2 | 2 | 2 | |
| 36 | Ball bearing | 9-01-0040-00 | | | | | | 2 | 2 | 2 | 2 | 2 | 2 | |
| 141 | Bearing spacer | 8-141-102-00 | | | | | | 1 | 1 | 1 | 1 | 1 | 1 | |
| 160 | Thermal protector (TSW2) | 9-62-8017-00 | 1 | 1 | 1 | 1 | 1 | 1 | 1 | 1 | 1 | 1 | 1 | |
| 161 | Lock Plate | 8-076-713-00 | 1 | 1 | 1 | 1 | 1 | 1 | 1 | 1 | 1 | 1 | 1 | |
| 162 | Screw - lock plate | 9-14-2704-00 | 1 | 1 | 1 | 1 | 1 | 1 | 1 | 1 | 1 | 1 | 1 | |

TABLE 2
Components of Support Plate Assembly

| Item No. | Description | Part Number ↓ | Brake Size Torque (lb-ft) | | | |
|----------|--|---------------|---------------------------|--------------|--------------|--------------|
| | | | 125 | 175 | 230 | 330 |
| | | | 5-42-1018-00 | 5-42-1019-00 | 5-42-1020-00 | 5-42-1021-00 |
| 8 | Solenoid lever and pinion assembly (comprised of Items 28, 32, 32R, 54, 71, 141 and 141A) | 5-66-7321-00 | 1 | 1 | 1 | 1 |
| 11 | Pressure spring (green) | 9-70-4601-00 | 1 | | | |
| | Pressure spring (yellow) | 9-70-6001-00 | | 1 | 1 | |
| | Pressure spring (red) | 9-70-5801-00 | | | | 1 |
| 12 | Solenoid assembly | 5-12-5529-00 | 1 | 1 | 1 | 1 |
| 13 | Solenoid link and bearing assembly | 5-55-2006-00 | 1 | 1 | 1 | 1 |
| 13C | Cap screw (solenoid link) | 8-157-703-00 | 1 | 1 | 1 | 1 |
| 13N | Nut (solenoid link) | 9-40-3732-00 | 1 | 1 | 1 | 1 |
| 17 | Lever arm assembly (with pressure buttons) | 5-17-2001-00 | 1 | 1 | 1 | 1 |
| 17B | Pressure button | 9-25-1908-00 | 2 | 2 | 2 | 2 |
| 17E | Eccentric sleeve (lever arm) | 8-054-201-00 | 1 | 1 | 1 | 1 |
| 17S | Set screw (lever arm) | 9-20-3004-00 | 2 | 2 | 2 | 2 |
| 19 | Pressure spring nut | 8-019-201-00 | 1 | 1 | 1 | 1 |
| 22 | Solenoid lever stop | 8-022-603-00 | 1 | 1 | 1 | 1 |
| 28 | Solenoid lever (component of Item 8) | | 1 | 1 | 1 | 1 |
| 32 | Pinion (component of Item 8) | | 1 | 1 | 1 | 1 |
| 32R | Retaining ring (component of Item 8) | | 1 | 1 | 1 | 1 |
| 53 | Manual release spring tube | 8-053-201-00 | 1 | 1 | 1 | 1 |
| 53P | Roll pin (spring tube) | 9-32-4012-00 | 1 | 1 | 1 | 1 |
| 54 | Sleeve (component of Item 8) | | 1 | 1 | 1 | 1 |
| 59 | Release spring | 9-71-0004-00 | 1 | 1 | 1 | 1 |
| 71 | Wrap spring (component of Item 8) | | 1 | 1 | 1 | 1 |
| 76 | Wrap spring stop | 8-076-203-00 | 1 | 1 | 1 | 1 |
| 76A | Holding plate (wrap spring stop) | 8-076-204-00 | 1 | 1 | 1 | 1 |
| 76S | Cap screw (spring stop) | 9-17-2812-00 | 2 | 2 | 2 | 2 |
| 76W | Lock washer (spring stop) | 9-45-1328-00 | 2 | 2 | 2 | 2 |
| 126 | Support plate and bearing assembly | 5-26-1002-00 | 1 | 1 | 1 | 1 |
| 130 | Pivot pin (lever arm) | 8-118-204-00 | 1 | 1 | 1 | 1 |
| 131 | Pivot pin (solenoid lever) | 8-131-201-00 | 1 | 1 | 1 | 1 |
| 131R | Retaining ring (pivot pin) | 9-03-0020-00 | 5 | 5 | 5 | 5 |
| 132 | Cap screw (solenoid mounting) | 8-350-002-00 | 4 | 4 | 4 | 4 |
| 132H | Holding plate (solenoid mounting) | 8-076-207-00 | 2 | 2 | 2 | 2 |
| 132L | Lock plate (solenoid mounting) | 8-076-206-00 | 2 | 2 | 2 | 2 |
| 134 | Pressure spring spacer | 8-134-001-02 | 1 | 1 | | |
| | Pressure spring spacer | 8-134-001-03 | | | 1 | |
| | Pressure spring spacer | 8-134-001-05 | | | | 1 |
| 138 | Bearing (washer type) | 8-138-201-00 | 7 | 7 | 7 | 7 |
| 138A | Bearing (washer type) | 8-138-701-00 | 2 | 2 | 2 | 2 |
| 141 | Wrap spring spacer (component of Item 8) | | * | * | * | * |
| 141A | Wrap spring sleeve spacer (component of Item 8) | | | | | |
| 146 | Release rod | 8-146-104-00 | 1 | 1 | 1 | 1 |
| 146B | Ball bearing (release rod) | 9-01-6801-00 | 1 | 1 | 1 | 1 |
| 146E | Extension (release rod) | 8-146-105-00 | 1 | 1 | 1 | 1 |
| 146P | Roll pin (release rod) | 9-32-4032-00 | 1 | 1 | 1 | 1 |
| 146R | Retaining ring (release rod) | 9-03-0007-00 | 1 | 1 | 1 | 1 |
| 146W | Spacer (release rod) | 9-45-0170-00 | 1 | 1 | 1 | 1 |
| 152 | Pressure spring stud | 8-152-201-00 | 1 | 1 | 1 | 1 |
| 152P | Pivot pin (spring stud) | 8-118-202-00 | 1 | 1 | 1 | 1 |
| 152R | Retaining ring (spring stud) | 9-03-0019-00 | 2 | 2 | 2 | 2 |
| 178 | Instruction plate | 8-078-054-00 | 1 | 1 | 1 | 1 |
| 178S | Drivescrew | 9-25-1303-00 | 2 | 2 | 2 | 2 |

*As required

Support Plate Assembly

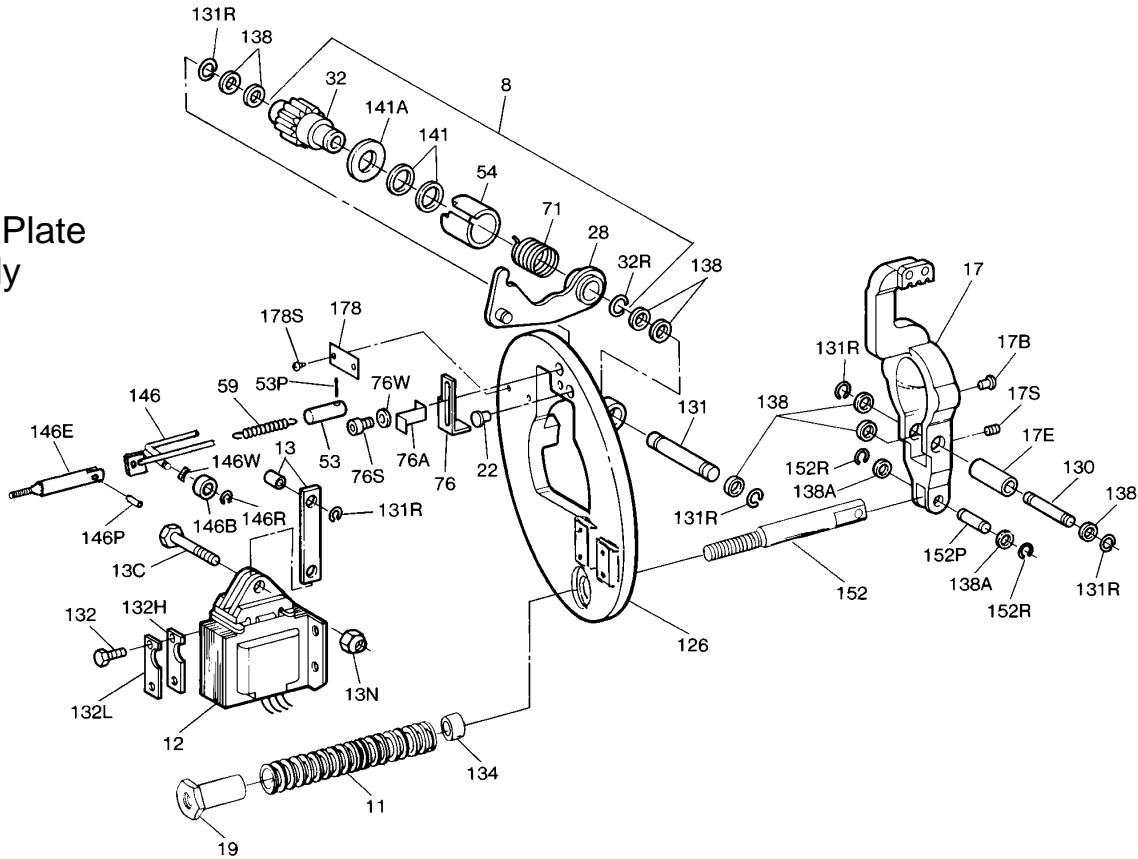

Solenoid and Coil

TABLE 3: Coil Assemblies

| Item | Description | | Part Number | Torque (lb-ft) | |
|------|-------------------------------------|-------------|--------------|-------------------|-----|
| | | | | 125 175 230 | 330 |
| 12A | No. 9 Coil Assembly 60 Hz | 115/230 Vac | 5-96-6907-05 | 1 | |
| | | 230/460 Vac | 5-96-6909-05 | 1 | |
| | | 115 Vac | 5-96-6901-05 | 1 | |
| | | 230 Vac | 5-96-6902-05 | 1 | |
| | | 460 Vac | 5-96-6904-05 | 1 | |
| | | 575 Vac | 5-96-6905-05 | 1 | |
| | No. K9 Coil Assembly 60 Hz | 115/230 Vac | 5-96-6957-05 | | 1 |
| | | 230/460 Vac | 5-96-6959-05 | | 1 |
| | | 115 Vac | 5-96-6951-05 | | 1 |
| | | 230 Vac | 5-96-6952-05 | | 1 |
| | | 460 Vac | 5-96-6954-05 | | 1 |
| | | 575 Vac | 5-96-6955-05 | | 1 |

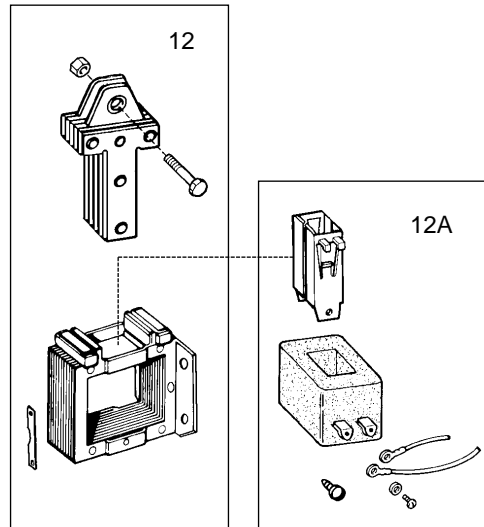

Above coils are UL Listed as Class A, however they contain Class H insulation.

TABLE 4: Contents of Assemblies

| Item No. | Description | Item No. | Description |
|----------|--|----------|---|
| 12 | Solenoid assembly (5-12-5529-00) 1 - Plunger 1 - Frame 2 - Lock plates 1 - Solenoid link cap screw 1 - Solenoid link nut | 12A | Coil assembly (5-96-69XX-00) 1 - Coil 2 - Lead wire & terminal assemblies 2 - Terminal screws 2 - Terminal lock washers 2 - Plunger guides 2 - Plunger guide screws |



Rexnord Industries, Inc.
Stearns Division
5150 S. International Drive
Cudahy, Wisconsin 53110
(414) 272-1100 Fax: (414) 277-4364 www.rexnord.com