

Installation and Service Instructions for Series 82,000

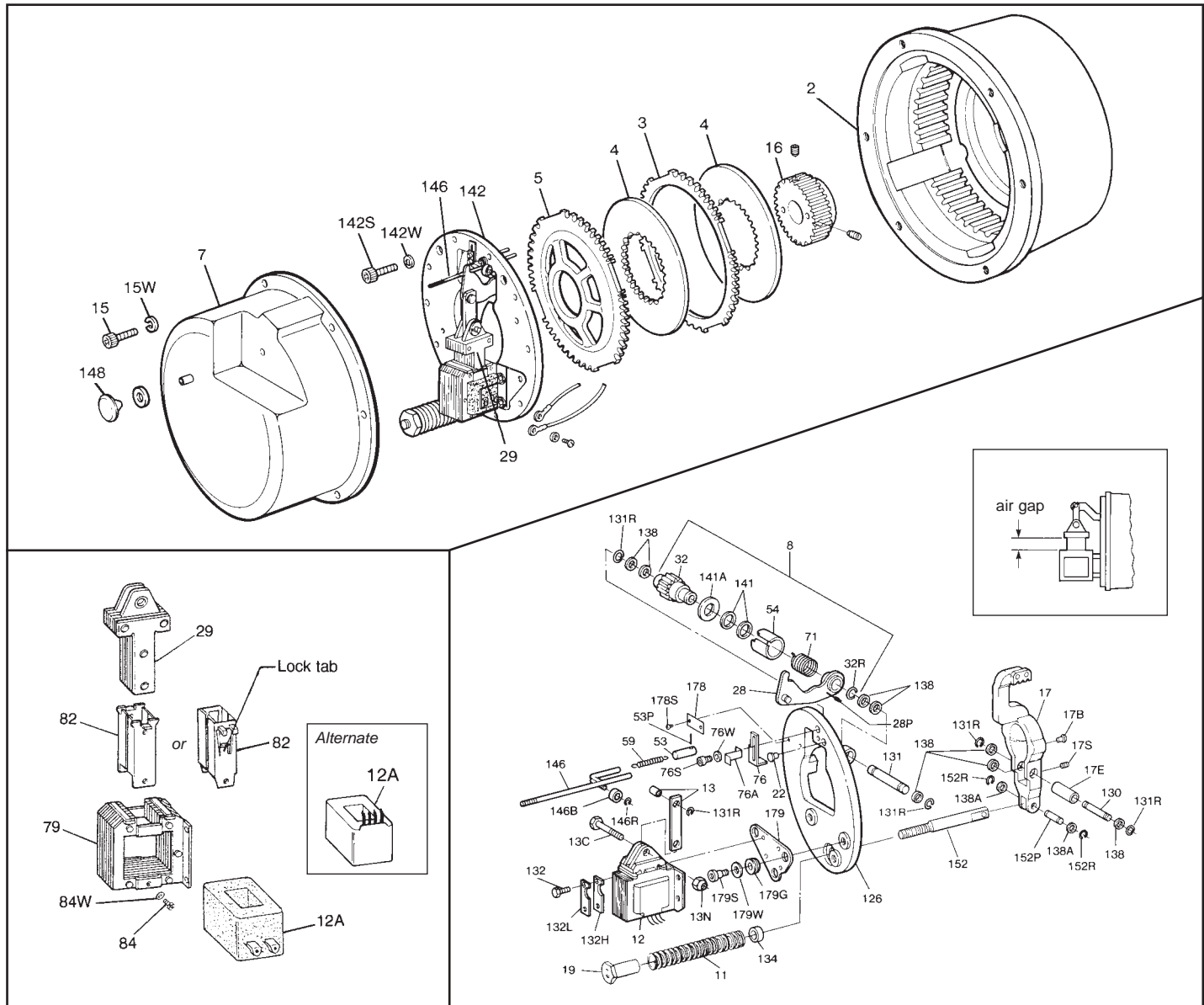

Figure 1

Important

Please read these instructions carefully before installing, operating, or servicing your Stearns brake. Failure to comply with these instructions could cause injury to personnel and/or damage to property if the brake is installed or operated incorrectly. For definition of limited warranty/liability, contact Rexnord Industries, Inc., Stearns Div., 5150 S. International Dr., Cudahy, WI 53110, (414) 272-1100.

Caution

1. Installation and servicing must be made in compliance with all local safety codes including Occupational Safety and Health Act (OSHA). All wiring and electrical connections must comply with the National Electric Code (NEC) and local electric codes in effect.

2. Do not install the brake in atmospheres containing explosive gases or dusts.
3. To prevent an electrical hazard, disconnect power source before working on the brake. If power disconnect point is out of sight, lock disconnect in the *off* position and tag to prevent accidental application of power.
4. Make certain power source conforms to the requirements specified on the brake nameplate.
5. Be careful when touching the exterior of an operating brake. Allow sufficient time for brake to cool before disassembly. Surfaces may be hot enough to be painful or cause injury.
6. Do not operate brake with housing removed. All moving parts should be guarded.

7. Installation and servicing should be performed only by qualified personnel familiar with the construction and operation of the brake.
8. For proper performance and operation, only genuine Stearns parts should be used for repairs and replacements.
9. After usage, the brake interior will contain burnt and degraded friction material dust. This dust must be removed before servicing or adjusting the brake.

DO NOT BLOW OFF DUST using an air hose. It is important to avoid dispersing dust into the air or inhaling it, as this may be dangerous to your health.

 - a) Wear a filtered mask or a respirator while removing dust from the inside of a brake.

- b) Use a vacuum cleaner or a soft brush to remove dust from the brake. When brushing, avoid causing the dust to become airborne. Collect the dust in a container, such as a bag, which can be sealed off.

General Description

The 82,000 Series is a spring-set, electrically released disc brake for controlled stopping and holding of a load. It is self-adjusting for friction disc wear and mounts directly to a NEMA C-face motor with 12-1/2" (AK) register and an 11" (AJ) bolt circle, machine with same register or Stearns foot mounting bracket. The nominal static torque is factory pre-set and should not be altered.

Operation

Each brake assembly consists of two, three, four or five molded or carrier ring friction discs fitted over a splined hub attached to and driven by a motor shaft. The friction discs are located alternately between an endplate, stationary disc(s) and a pressure plate. The stationary disc(s) and pressure plate are restrained from rotating through splines in the endplate. A solenoid, lever system, and a pressure spring are located on a support plate. A fitted housing, attached to the endplate, encloses the working parts. The housing also provides location and support for a manual release lever.

The release of the brake occurs when the solenoid coil is energized causing the solenoid plunger to travel a specified distance and, through the lever system, overcome the pressure spring force. The lever system in its travel disengages from the pressure plate which permits the friction discs to rotate when the motor is energized. When the motor and solenoid coil are de-energized the pressure spring moves the lever system toward the pressure plate, applying a force to stop the rotation of the friction discs.

When the motor is off and the load is to be moved without energizing the motor, the manual release lever or rod should be used. This removes the holding torque from the motor shaft, allowing it to be rotated by hand, however drag may be noted. The brake will remain in the manual release position until the release lever or rod is returned manually to its set position, or until the brake is re-energized electrically and the release lever or rod returns to its set position automatically.

Note: The motor should not be run with the brake in the manual release position to avoid overheating of friction discs.

I. Installation Procedure

(See Figure 1)

Note 1: For optimum results, position brake so that solenoid plunger (29) is above the frame (79) when installed. The brake may be mounted horizontally with the solenoid plunger above the frame, or if specifically modified, vertically above or vertically below the motor. **If motor is to be ceiling or horizontally wall mounted, brake must be oriented so the brake plunger is above frame when motor is installed.**

Note 2: If foot mounted, secure foot mounting bracket to foundation. The use of

dowels to insure permanent alignment is recommended. Foot, machine or C-face mounted brake must be carefully aligned within .007" on concentricity and face runout. Shaft runout should be within .002" T.I.R. Maximum permissible shaft endfloat is .020".

- A. Unscrew manual release knob (148), housing screws and washers (15 and 15W) and remove housing (7).
- B. Depress solenoid plunger and pull release rod (146) back to lock brake mechanism in manual release position or plunger may be tied to frame.
- C. Remove entire support plate assembly (142) by evenly unscrewing and removing screws and lock washers (142S and 142W).
- D. Remove pressure plate (5), friction discs (4) and stationary disc(s) (3).

Note 3: Vertically mounted brakes will have special pins which guide spacer springs and, in some cases, spring washers. Note color coded sequence of springs and location of washers, if used, or refer to Instruction P/N 8-078-932-05 (Sheet 301.2) for proper assembly.

- E. Attach endplate assembly (2) to mounting face of motor using four socket head cap screws (not supplied) torque per manufacturer's specification. (Head of mounting bolts must not project above friction surface.)
- F. Position hub (16) and key (not supplied) on the motor shaft so that face of hub will protrude outboard approximately 3/32" to 1/8" beyond the face of the last outboard friction disc. (Position may be determined by assembling friction discs and stationary disc(s) onto hub, noting hub position, and removing discs.) If brake utilizes vertical mounting springs, do not assemble them when measuring for hub location. On some applications, particularly in vertical position, a set screw dimple drilled into shaft is recommended.

Tighten two hub set screws (16S).

Torque set screws as follows:

- 5/16" diameter – 156 in-lb
- 3/8" diameter – 290 in-lb
- 1/2" diameter – 620 in-lb

- G. Assemble friction discs and stationary disc(s) alternately. Pressure plate completes disc pack assembly. If vertical style, replace springs, etc. in proper order. If sequence is lost, see Instruction P/N 8-078-932-05 (Sheet 301.2).

Note 4: Friction discs should be free to slide on hub and the stationary disc(s) and pressure plate should be free to slide in endplate.

- H. Mount support plate assembly drawing screws down evenly. Be sure the assembly is mounted with the solenoid plunger above the solenoid frame on horizontally installed brakes. (See *Installation*, Note 1.) Torque screws with lock washers to 150 in-lbs.

Note 5: If manual release rod is not in manual release position and has allowed the mechanism to over-adjust and the support plate will not seat against the endplate, it will have to be reset. In this case the lever arm

(17) throat will be near, or touching, the pinion (32) teeth. Loosen pressure spring nut (19) until pressure spring (11) is free. Lift the plunger (29) to its full extension to release the wrap spring. Pull the lever arm (17) forward until it is only engaged on the last two teeth of the rack assembly on the lever arm. Mount support plate and retighten spring nut until snug. Torque to 50 lb-ft. Lift plunger to maximum travel and release.

- I. Disengage manual release lever by depressing plunger sufficiently to allow release rod to retract or remove plunger to frame tie-down.
- J. Manually depress solenoid plunger into the solenoid frame and release. Repeat this process several times to set solenoid air gap. (Check *Self-Adjust Maintenance* Section for proper air gap measurement or corrective action for loss of gap.)
- K. Connect all internal electrical hardware. (See Section on *Electrical Connection of Brake*.)
- L. Check that friction discs rotate freely when the solenoid plunger is held firmly against the solenoid frame. If binding or sticking occurs recheck Steps E, F & G.
- M. Replace housing, screws, lock washers, and manual release knob. On DTWP install gaskets provided.

II. Electrical Connection

CAUTION 1: Inverter Motor and Special Control Systems. This brake contains either a single phase AC coil or DC coil that requires instantaneous power within $\pm 10\%$ of rating at the coil. A separate power source is required when this brake is used in conjunction with a motor or control system that limits voltage or current input (i.e. inverter motors) or causes a ramping of the power supply.

CAUTION 2: Class H coils with terminals. Do not bend lead wire crimp connection as this causes a fatigue in the metal which may break under vibration.

Note 1: Brake coil connections described here cover common motor connections. For non-standard motor or control connection, contact respective supplier or Stearns Division.

Note 2: Be sure lead wires to coil are not tight or pinched, and that leads will not be rubbed by friction disc, trapped between solenoid plunger and frame, caught between lever arm and endplate, or by linkage.

Note 3: On brake with space heater, connect to appropriate power source. Heater is to be energized continuously, even during storage, if rusting may occur.

Note 4: Consult factory for inrush current on 115 or 230 volt AC or DC coil so adequate switch and power supply is provided.

A. AC coils, single or dual voltage

1. Dual voltage coils may be factory preconnected for high voltage unless otherwise specified on brake purchase order. Checking coil connection is suggested.
2. On single voltage coils, connect coil to any two leads on three-phase motors of the same voltage as the brake. Refer to brake nameplate and coil number for

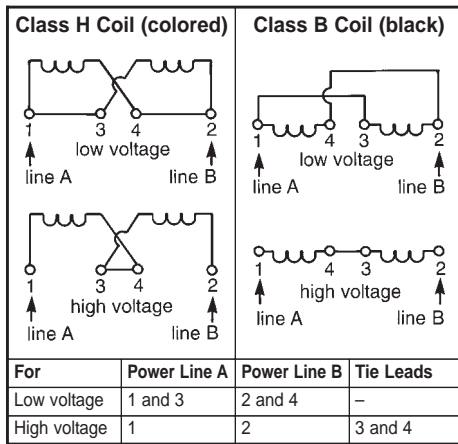

Figure 2

correct voltage and frequency. See Figure 2 for dual voltage coil connection and connect to any two leads of three-phase motor of the same voltage. The brake can also be wired to external switch contacts providing proper voltage other than that used to control the motor. Normally, the motor and brake contacts are interlocked.

B. Connecting AC solenoid coils on dual voltage 230/460 three-phase motors

To use a 230 volt coil (or a 230/460 dual voltage coil connected for 230 volts) with a 230/460 dual voltage three-phase motor, the brake leads are connected across two motor terminals as shown, or other equivalent combinations. If a 230 volt brake coil is connected as shown in Figures 3 and 4 the

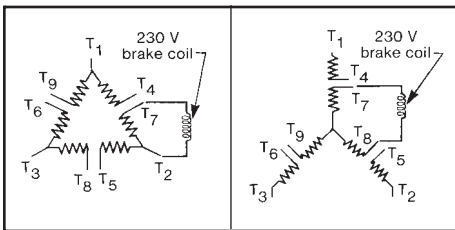

Figure 3

Figure 4

motor can be operated on either 230 volts or 460 volts with no effect on brake operation.

C. DC coils – all models

1. All Stearns DC coils are single voltage and have dual windings. A high current pull-in winding is initially energized to start solenoid plunger movement, while a low current holding winding is momentarily short circuited via a normally closed switch mounted on solenoid frame. When the solenoid plunger is almost seated, an actuator arm, welded to it, opens the switch, removes the short circuit from the holding winding, and connects it in series with the pull-in winding. Due to the high initial current demand of a DC solenoid, a separate DC power source of adequate current capacity is usually required.

Caution! Never use a series resistor to drop power supply voltage to solenoid coil as brake malfunction will result!

2. Connect proper power source to two terminals of coil or the two free leads (red and black) of four lead coil. Polarity is immaterial. Two coil leads are preconnected at factory to a DC switch on solenoid in parallel with arc suppression module.

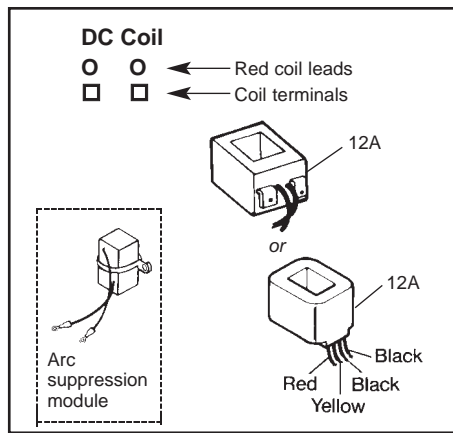

Figure 5

III. General Maintenance

Warning! Any mechanism or load held in position by the brake should be secured to prevent possible injury or damage to equipment before any disassembly of the brake is attempted or the manual release knob or lever is operated on the brake. Observe all cautions listed at the beginning of this manual.

Note: Do not lubricate any part of the brake as this may cause a malfunction and/or a loss of torque.

A. Coil replacement

1. Unscrew manual release knob (148), housing screws (15) and washers (15W) and remove housing.
2. Disconnect coil (12A) from circuit.
3. Remove solenoid link screw (13C) and lift plunger (29) from frame (79).
4. For metallic plunger guides (82) remove plunger guide screws (84) and lock washers (84W). Remove both plunger guides (82) by prying up on the flanges. Discard plunger guides.
 - a) To remove non-metallic plunger guides (82) remove screws (84) and lock washers (84W). Insert shim stock or other thin gauge material at top center of coil between coil and solenoid frame. Push to release lock tab while lifting up on plunger guide. Repeat for other plunger guide.
5. Slide coil (12A) out from solenoid frame (79) in the direction of the coil leads or terminals. If necessary, tap coil lightly with a soft hammer. If solenoid coil had burned out, be sure to remove all foreign material from the solenoid plunger (29) and solenoid frame.
6. Install new coil (12A) into solenoid frame with same relative position as old coil. Install coil, alternate (12A), with lead wires upward on outboard side of solenoid. If solenoid actuated switch or DC coil is used, install coil with lead wires upward toward inboard side of solenoid. Assemble new metallic plunger guides (82), plunger guide screws (84) and lock washers (84W) if used.
 - a) Assemble new non-metallic plunger guides (82) by inserting into position and pushing down until lock tab snaps under top bar of solenoid frame. On

coil (12A) with terminals, check that lock tab face is flush with inside surface of guide. If not, file chamfer (about 1/16" by 45°) on coil at lock tab area. Install plunger guide screws (84) and lock washers (84W) if used.

7. Reassemble plunger into solenoid by reversing Steps 3, 2 and 1.
8. Depress solenoid plunger and release as in Step J of the *Installation Procedure*.

B. Renewal of friction discs

Note: Disc pack should be replaced when total wear of the disc pack reaches .375" or any one individual disc has worn beyond .188.

1. Follow Steps A through D of the *Installation Procedure*.
2. Follow Steps G through M of the *Installation Procedure*.

C. Self-adjust maintenance

The solenoid is factory set with a 1-3/8" to 1-7/16" air gap, and requires no resetting, even when changing friction discs. The air gap is determined by the position of the wrap spring stop (76). The air gap is measured between mating surfaces of plunger and solenoid frame. See Figure 1.

Note: To measure solenoid air gap on vertically mounted brakes, grasp solenoid link to hold plunger in a free horizontal position, and move toward solenoid frame until spring pressure is felt. Holding firmly in this position measure air gap between mating (ground) surface on solenoid frame and solenoid plunger.

Should gap have changed, inspect position of the wrap spring stop and adjust air gap as follows:

1. Tang of wrap spring (71) must be below and must make contact with wrap spring stop when solenoid lever (28) is manually lifted to a maximum position. If wrap spring stop (76) is bent outward, allowing tang to bypass it, rebend to a square position and assemble correctly.
2. If (stop) screws (76S) had been loosened and retightened, the air gap may require resetting. The air gap may be increased by raising slightly, or decreased by lowering slightly, wrap spring stop (76). Be sure to retighten (stop) screws (76S). Manually lift plunger to maximum travel and release. Depress plunger, manually or electrically, and allow it to snap up. Repeat several times, then recheck air gap. (For vertically mounted brakes refer to Note at start of this Section C.)
3. Should air gap have disappeared the solenoid lever and pinion assembly (8) may have become contaminated due to lubrication or residue as a result of overheating of brake. Cleaning is required. Remove support plate assembly following Steps B and C of *Installation Procedure*. Loosen pressure spring nut (19) until pressure spring (11) is free. Remove retaining rings (131R) from solenoid lever pivot pin (131). Note sequence of washer type bearings (138) and push pivot pin out to free assembly. Remove retaining ring (32R) from assembly and remove pinion (32) by

rotating as it is pulled out. Remove sleeve (54). Remove wrap spring from solenoid lever by gently pulling and rotating. Parts should be thoroughly cleaned in a clean solvent that does not leave a film (M.E.K. or equivalent). Dry all parts thoroughly and reassemble. Be sure wrap spring is tight against side face of solenoid lever and the end of the last turn touches, without preload, spirol pin (28P). Spirol pin should protrude into solenoid lever for no more than the width of this turn. Reassemble in reverse order of Steps in this paragraph and Steps H through M of *Installation Procedure*.

4. Check condition and position of pinion and rack (part of lever arm assembly [17]). If pinion shows excessive wear, replace entire solenoid lever and pinion assembly (8) following above procedure. If rack shows excessive wear remove and replace lever arm assembly as follows:

- a) Loosen pressure spring nut until pressure spring is free. Remove nut, spring and pressure spring spacer (134).
- b) Remove retaining ring (152R) and washer type bearing (138A) from spring stud pivot pin (152P) and remove pin and spring stud (152).
- c) Remove retaining ring (131R), bearing type washers (138), pivot pin (130) and lever arm (17). Remove two set screws (17S) and eccentric sleeve (17E) from lever arm.
- d) Install new lever arm following Steps c and b in reverse order. Do not tighten pressure spring nut, but snug the two set screws (17S) of eccentric sleeve (17E) with hole in line with set screws.

Upon completion of installation of new lever arm it will be necessary to check and/or adjust the backlash between the rack and pinion.

- a) The backlash at either end of the rack should not exceed .003 and the movement of the rack over the pinion should be smooth and free of binding. Check as follows:
- b) Lift solenoid plunger to its maximum position and advance lever arm forward toward the pinion. Position the lever arm so the first two teeth of the rack will be engaged with one tooth of the pinion when the plunger is resealed against the solenoid frame. The one tooth of the pinion should be over the centerline of the solenoid lever pivot pin.
- c) Holding the plunger in the seated position move lever arm back and forth and determine backlash.
- d) Lift plunger to its maximum position and advance lever arm until the last two teeth of the rack are engaged with one tooth of the pinion, when the plunger is resealed against the solenoid frame. The one tooth of the pinion should be over the centerline of the solenoid lever pivot pin.

- e) Holding the plunger in the seated position move lever arm back and forth and determine backlash.
- f) To adjust backlash loosen lever arm set screws (17S). To reduce backlash rotate lever arm eccentric sleeve (17E) counterclockwise. To increase backlash rotate eccentric sleeve clockwise.
- g) After backlash adjustment has been completed, tighten lever arm set screws to 87 in-lbs torque.

Do not tighten spring nut until support plate assembly is mounted on the endplate. Follow Steps H through J of *Installation Procedure*. Adjust solenoid air gap following Step 2 of *Self-Adjust Maintenance*. Complete assembly of brake by following Steps K through M of *Installation Procedure*.

IV. Troubleshooting

A. If brake does not stop properly, coasts, or overheats:

1. Check that manual release knob is not in released mode.
2. Check for excessively worn, charred or broken friction discs.
3. Check that hub has not loosened and shifted on motor shaft.
4. Check that friction discs slide freely over hub. Clean hub and/or file burrs and nicks if required.
5. Check that stationary disc(s) and/or pressure plate can move freely in endplate and that they are not warped from overheating.
6. Check endplate splines for wear in the areas where stationary disc(s) and/or pressure plate make contact. Grooves in splines can prevent free disc movement and result in torque loss or friction disc breakage.
7. On vertically mounted brakes, check that springs are installed correctly and that stationary disc(s) can slide freely over vertical mounting pins. Also check for wear on plunger guide bracket.
8. Check that pressure spring nut (19) was properly tightened. Correct compressed spring height measured to top face of support plate with new friction discs should be approximately:

Torque (lb-ft)	Compressed Spring Length
125	4-23/32
175	4-23/32
230	4-27/32
330	5-3/32
440	5-3/32
550	5-3/32

9. Check solenoid air gap and other Items per *Self-Adjust Maintenance*, Section III-C. Adjust if necessary.
10. Check that solenoid linkage can move freely. It requires approximately 18 lbs of pressure on the 125 lb-ft; 23 lbs on the

175 and 230 lb-ft; 28 lbs on 330, 440 and 550 lb-ft to seat solenoid plunger to frame on a correctly functioning brake.

11. Check voltage reading at coil terminals against coil voltage rating.
12. Check that brake coil is energized at the same time as, or prior to, motor and de-energized at the same time, or after, motor.
13. If stopping time exceeds 1 second, or if the application requires more than five stops per minute, check the thermal requirements to stop load against the thermal capacity of the brake.
14. If throat of lever arm (17) is near or touching pinion teeth (32), friction discs (4) are to be replaced.

B. If brake hums, solenoid pulls in slowly, or coil burns out:

1. Check Items A-9 and A-11.
2. Check if shading coils are broken.
3. Check for worn plunger guides or if plunger rubs on solenoid frame laminations.
4. Check for worn solenoid plunger and frame.
5. Check if solenoid is dirty.
6. Check if solenoid mounting screws have loosened.
7. Check for worn or binding linkage. For normal pressure required to seat solenoid plunger to frame see A-10.
8. Check for excessive voltage drop in motor line when motor is started. Check wire gauge of supply line against motor starting current and solenoid inrush current. Measure voltage drop at solenoid coil terminals during maximum inrush current condition. To accomplish this, insert a block of wood, or other non-magnetic materials, between solenoid plunger and frame. Block thickness should approximately equal solenoid air gap. Energize motor and brake simultaneously, take reading and immediately shut down. This is to prevent motor, brake, or solenoid burnup.

C. If brake is noisy during stopping and/or friction discs shatter:

1. Check for worn motor bearings allowing shaft runout.
2. On foot mounted brakes, recheck alignment.
3. On either style brake, check hub position on shaft. The outboard face of hub should protrude 3/32" to 1/8" beyond face of outboard friction disc.
4. On motor mounted style, check motor shaft endfloat. It should not exceed 0.020".
5. On motor or machine mounted style, check concentricity of endplate and C-face register. See *Installation Procedure*, Note 2.