

This drawing is the property of MELTRIC Corporation, Franklin (Milwaukee), Wisconsin, USA. Any unauthorized copying of this drawing by any means, ENG/RD/06 REV: 20 ISSUED DATE: 1/15/11 or disclosure of its contents to any person not authorized by MELTRIC Corporation or its agents to receive it, is strictly prohibited.

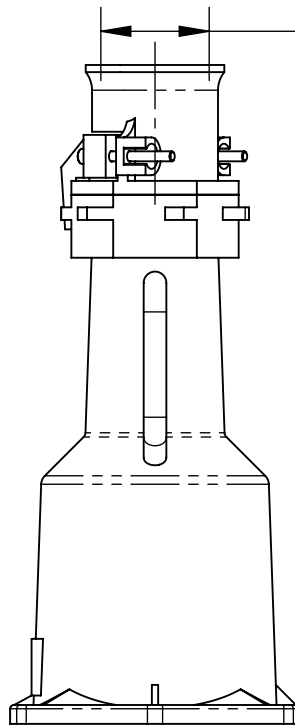

[86mm]
 ϕ 3.39in
 MAXIMUM CABLE
 BUNDLE DIA.

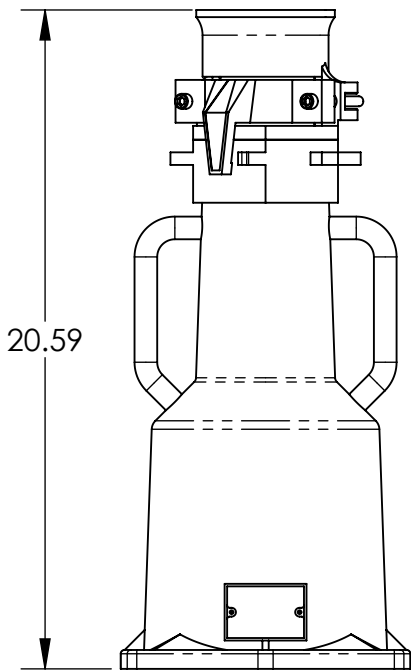
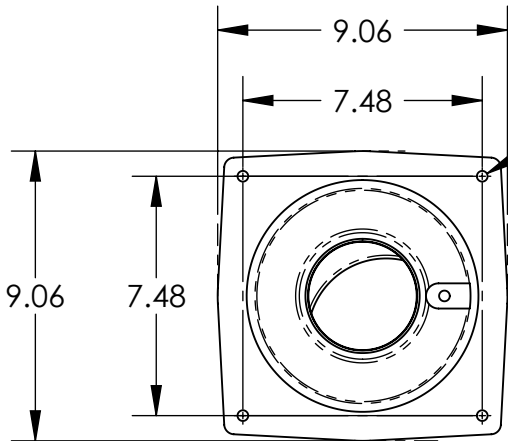
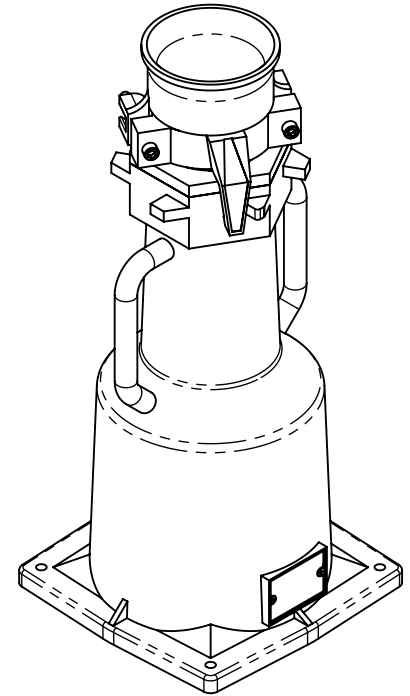

4X
 M10X1.5

PART NUMBER	CABLE RANGE
49-3A013-200	2.000" - 2.125"
49-3A013-225	2.125" - 2.250"
49-3A013-237	2.250" - 2.375"
49-3A013-250	2.375" - 2.500"
49-3A013-275	2.500" - 2.750"
49-3A013-300	2.750" - 3.000"
49-3A013-312	3.000" - 3.125"
49-3A013-335	3.125" - 3.350"
49-3A013-350	3.350" - 3.390"

APPROX WEIGHT = 10 LBS.

TOLERANCES UNLESS OTHERWISE SPECIFIED			
MACHINED SURFACES $\sqrt{125}$ MAX GROUND SURFACES $\sqrt{32}$ MAX ANGLE TOLERANCE $\pm 1^\circ$ REMOVE BURRS & SHARP EDGES TO .015 MAX.	ENGLISH 0.X ± 0.05 0.XX ± 0.01 0.XXX ± 0.005		
DIMENSIONS SHOWN IN OVALS ARE INSPECTION DIMENSIONS.		SCALE: NTS MATERIAL: PAINTED METAL	PART NUMBER: 49-3A013-xxx
	SHEET: 1 OF 1		REVISION: _____