

This drawing is the property of MELTRIC Corporation, Franklin (Milwaukee) Wisconsin, USA. Any unauthorized copying of this drawing by any means, or disclosure of its contents to any person not authorized by MELTRIC Corporation or its agents to receive it, is strictly prohibited. ENG/RD/06 REV: 20 ISSUED DATE: 11/15/11

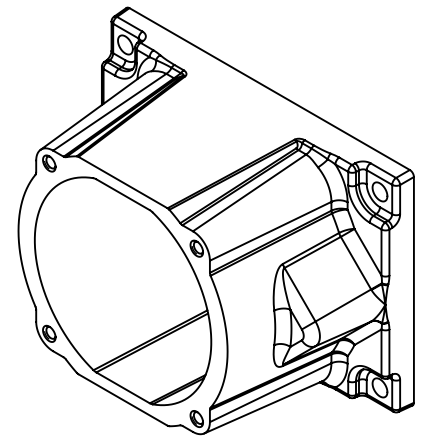
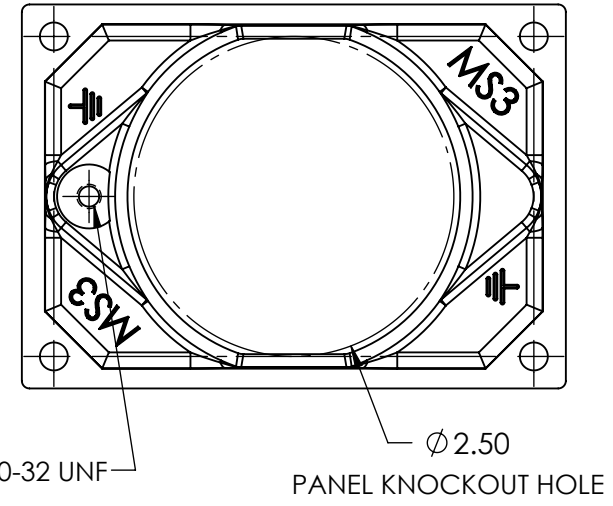
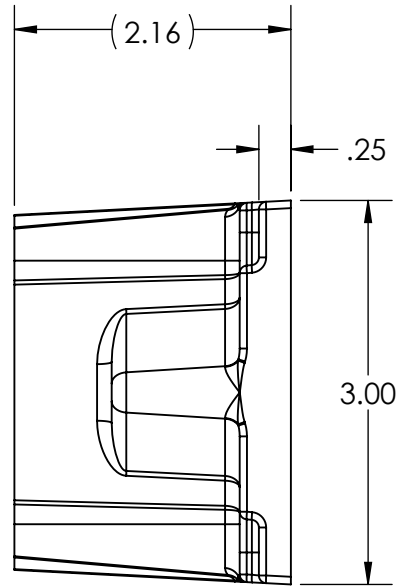
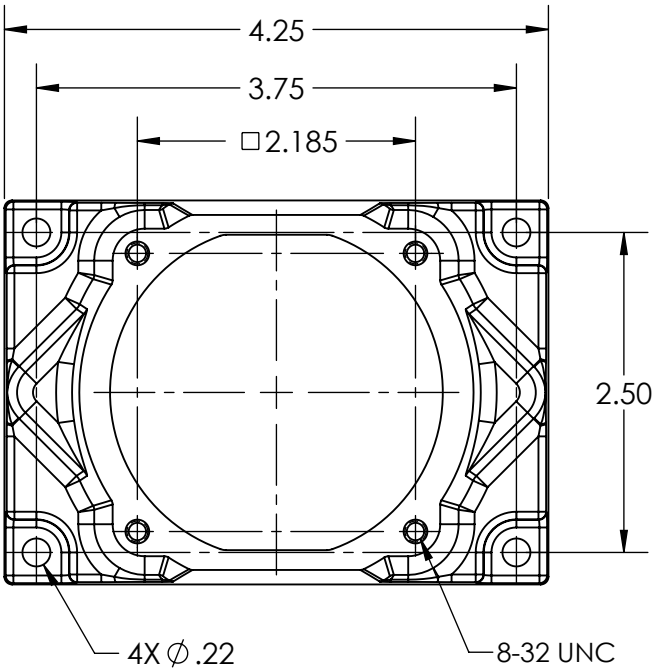

TOLERANCES UNLESS OTHERWISE SPECIFIED		 A COMPANY OF MARECHAL ELECTRIC		DRAWING TITLE:	
MACHINED SURFACES $\sqrt[125]{\text{MAX}}$ GROUND SURFACES $\sqrt[32]{\text{MAX}}$ ANGLE TOLERANCE $\pm 1^\circ$ REMOVE BURRS & SHARP EDGES TO .015 MAX. DIMENSIONS SHOWN IN OVALS ARE INSPECTION DIMENSIONS.	ENGLISH 0.X ± 0.05 0.XX ± 0.01 0.XXX ± 0.005			SIZE 3 BLACK METAL STRAIGHT ADAPTER	
		DRAWN: _____ DATE: _____	APPROVED: _____ SCALE: NTS	PART NUMBER: 5K3M0	
		SHEET: 1 OF 1			REVISION: _____