

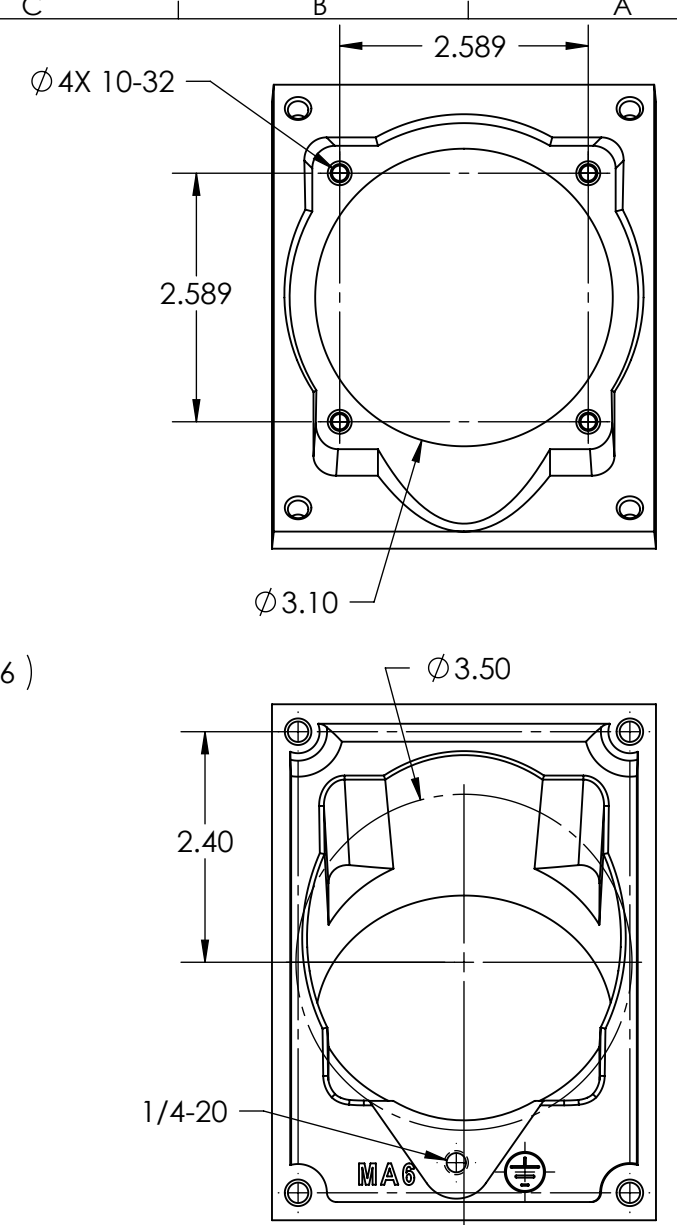

This drawing is the property of MELTRIC Corporation, Franklin (Milwaukee), Wisconsin, USA. Any unauthorized copying of this drawing by any means, ENG/RD/06 REV: 20 ISSUED DATE: 1/15/11 or disclosure of its contents to any person not authorized by MELTRIC Corporation or its agents to receive it, is strictly prohibited.

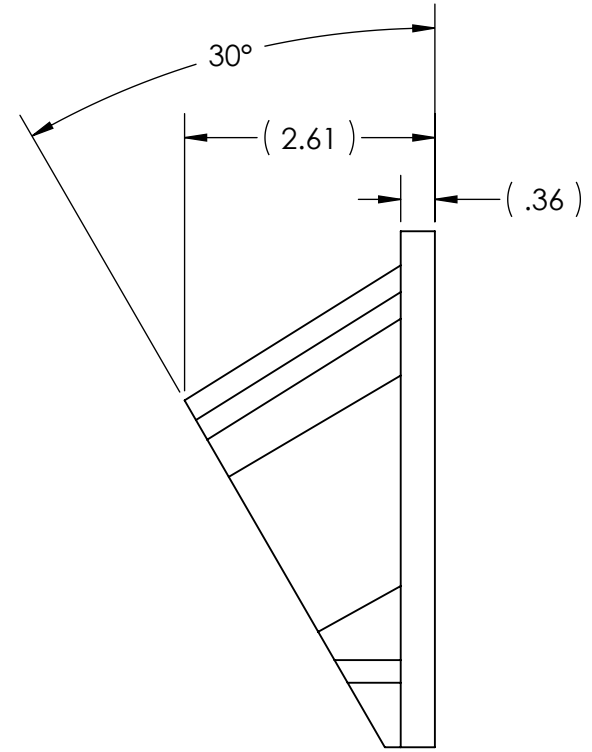
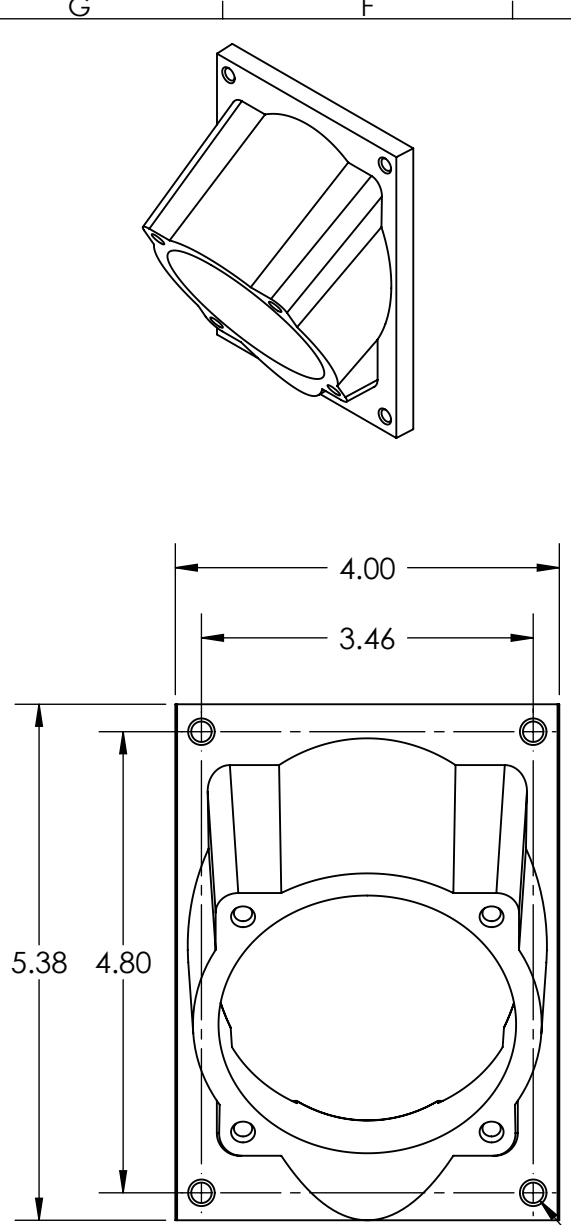

PANEL KNOCKOUT HOLE

TOLERANCES UNLESS OTHERWISE SPECIFIED	
MACHINED SURFACES $\sqrt[125]{\text{MAX}}$	ENGLISH 0.X ±0.05 0.XX ±0.01 0.XXX ±0.005
GROUND SURFACES $\sqrt[32]{\text{MAX}}$	
ANGLE TOLERANCE ±1°	
REMOVE BURRS & SHARP EDGES TO .015 MAX.	
 DIMENSIONS SHOWN IN OVALS ARE INSPECTION DIMENSIONS.	

		DRAWING TITLE:	
DRAWN	APPROVED	SIZE 4 BLACK METAL 30° ANGLE ADAPTER	
DATE:	SCALE	MATERIAL:	
	NTS	BLACK PAINTED METAL	
SHEET:	PART NUMBER	REVISION	
1 OF 1	5K4M3		