

DESCRIPTION:
GEARMOTOR 33A3BEPM-W4 METRIC

SHEET: 1/1	UNLESS OTHERWISE SPECIFIED:
SCALE: 2:3	UNITS ARE IN mm [INCHES]
C	ANGLES: X°:±3° X.X°:±0.5°

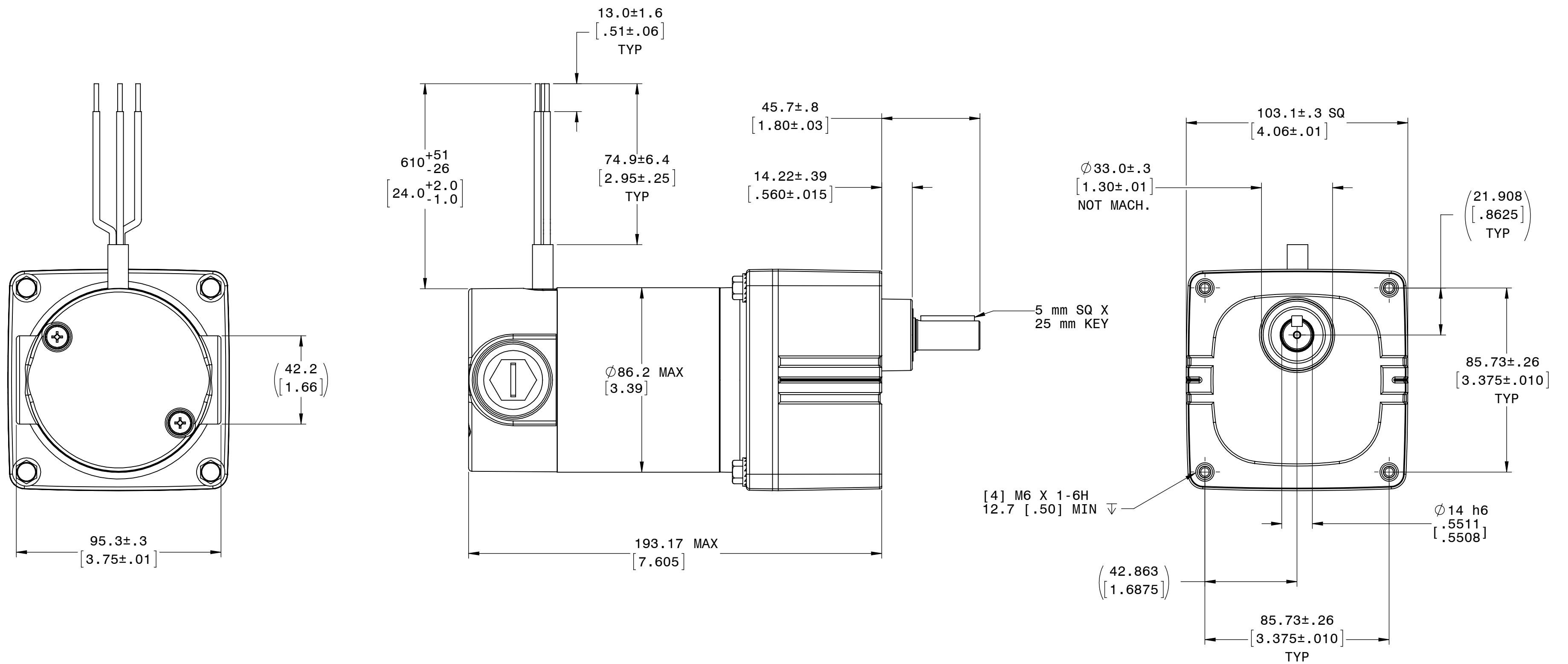

REPRESENTATIVE OF MODEL NUMBER(S):

6247

