

DESCRIPTION:  
GEARMOTOR 33A3BEPM-Z2 METRIC

SHEET: 1/1	UNLESS OTHERWISE SPECIFIED:
SCALE: 1:1	UNITS ARE IN mm [INCHES]
<b>C</b>	ANGLES: X°:±3° X.X°:±0.5°

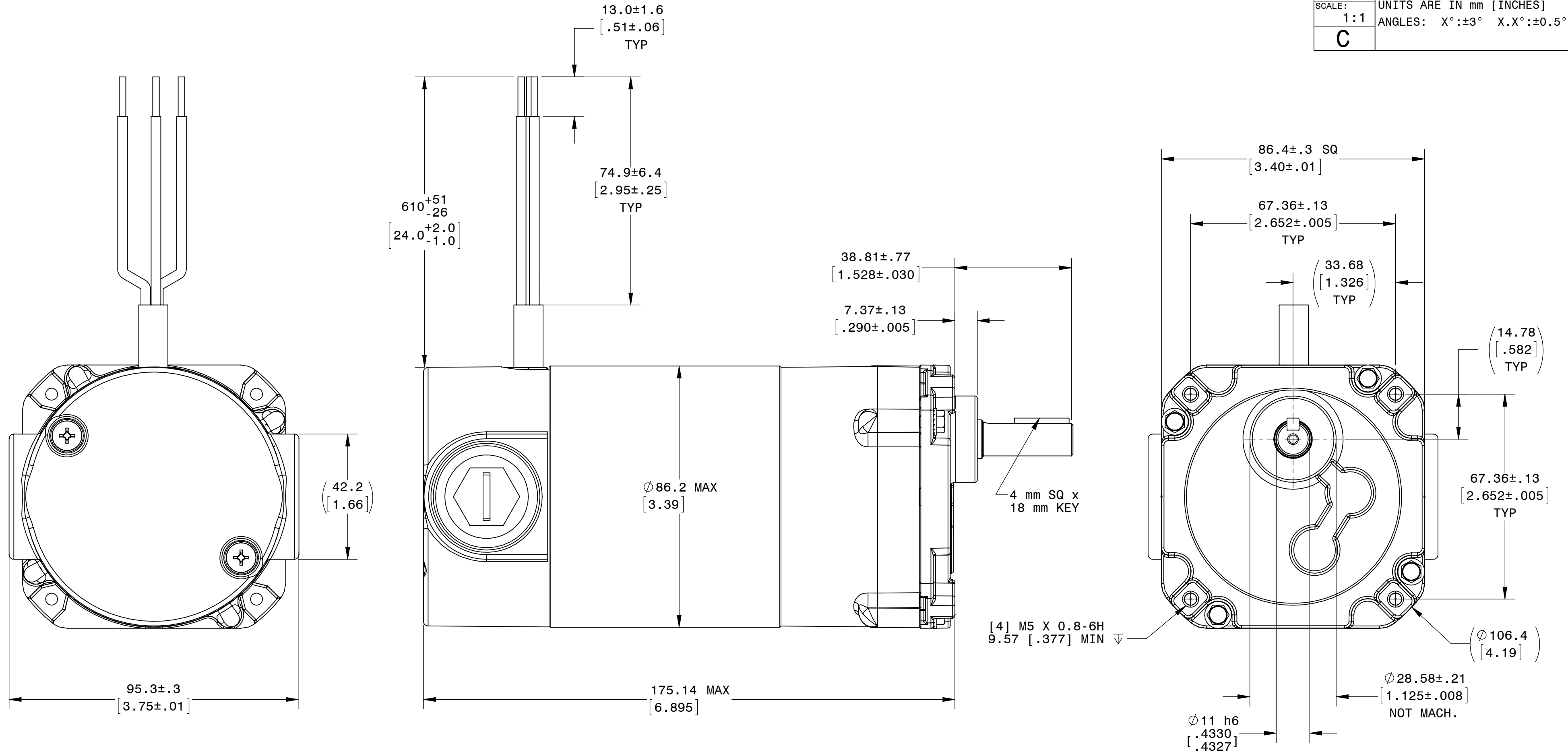

4 mm SQ x  
18 mm KEY

[4] M5 X 0.8-6H  
9.57 [.377] MIN

REPRESENTATIVE OF MODEL NUMBER(S):  
6266

