

DESCRIPTION: KIT BRACKET 33A-D/Z METRIC	
SHEET: 1/1	UNLESS OTHERWISE SPECIFIED:
SCALE: 1:2	UNITS ARE IN INCHES [mm]
C	TOLERANCES: .XX:±.01 .XXX:±.005
	ANGLES: X°:±3° X.X°:±0.5°

- NOTES:
 1. MATERIAL: .090 THICKNESS COLD ROLL STEEL
 2. [4] M5-0.8 X 12 LONG SCREWS SUPPLIED WITH BRACKET
 3. [4] LOCKWASHER FOR #10 SCREWS

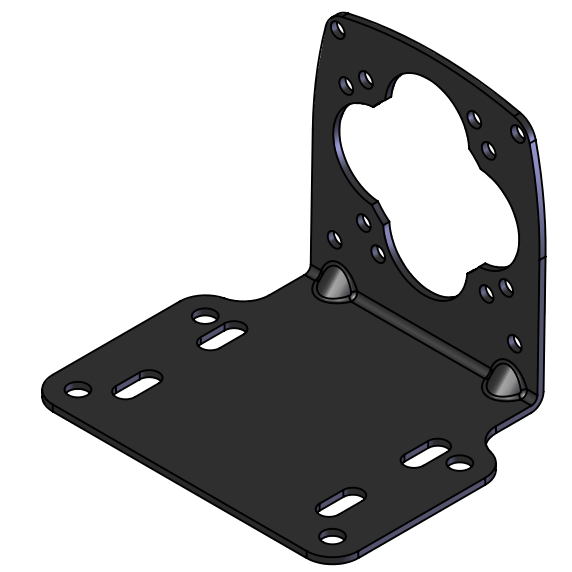
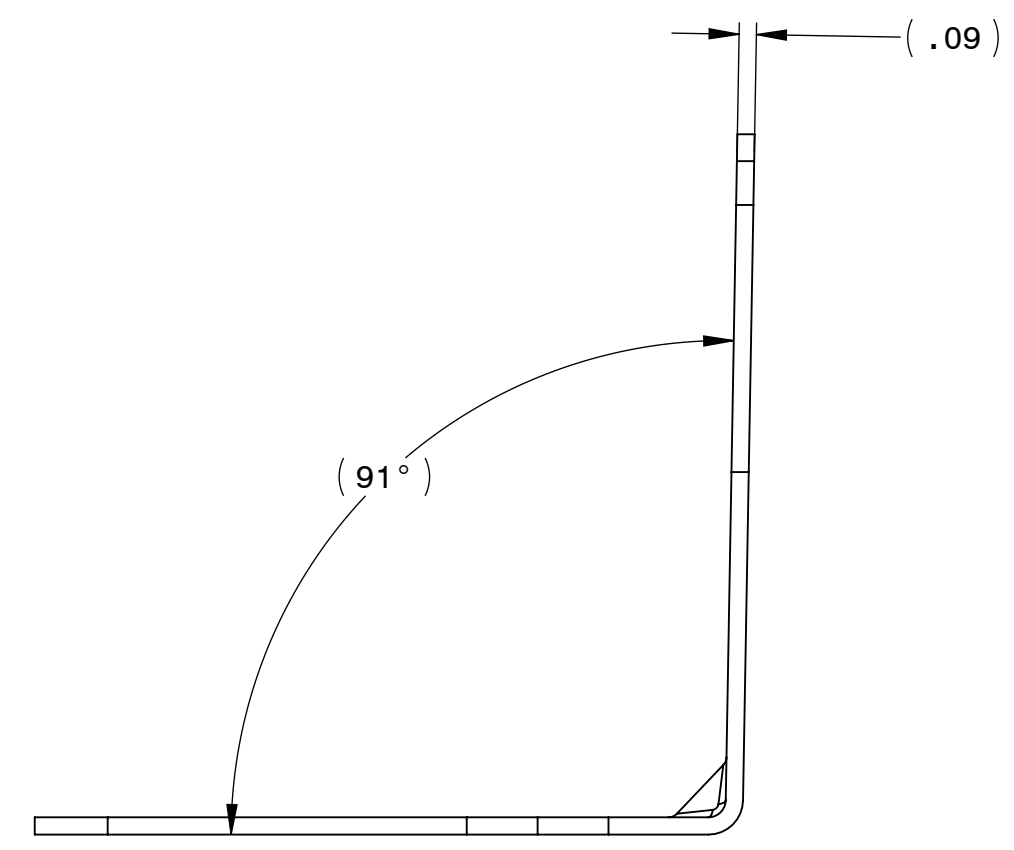
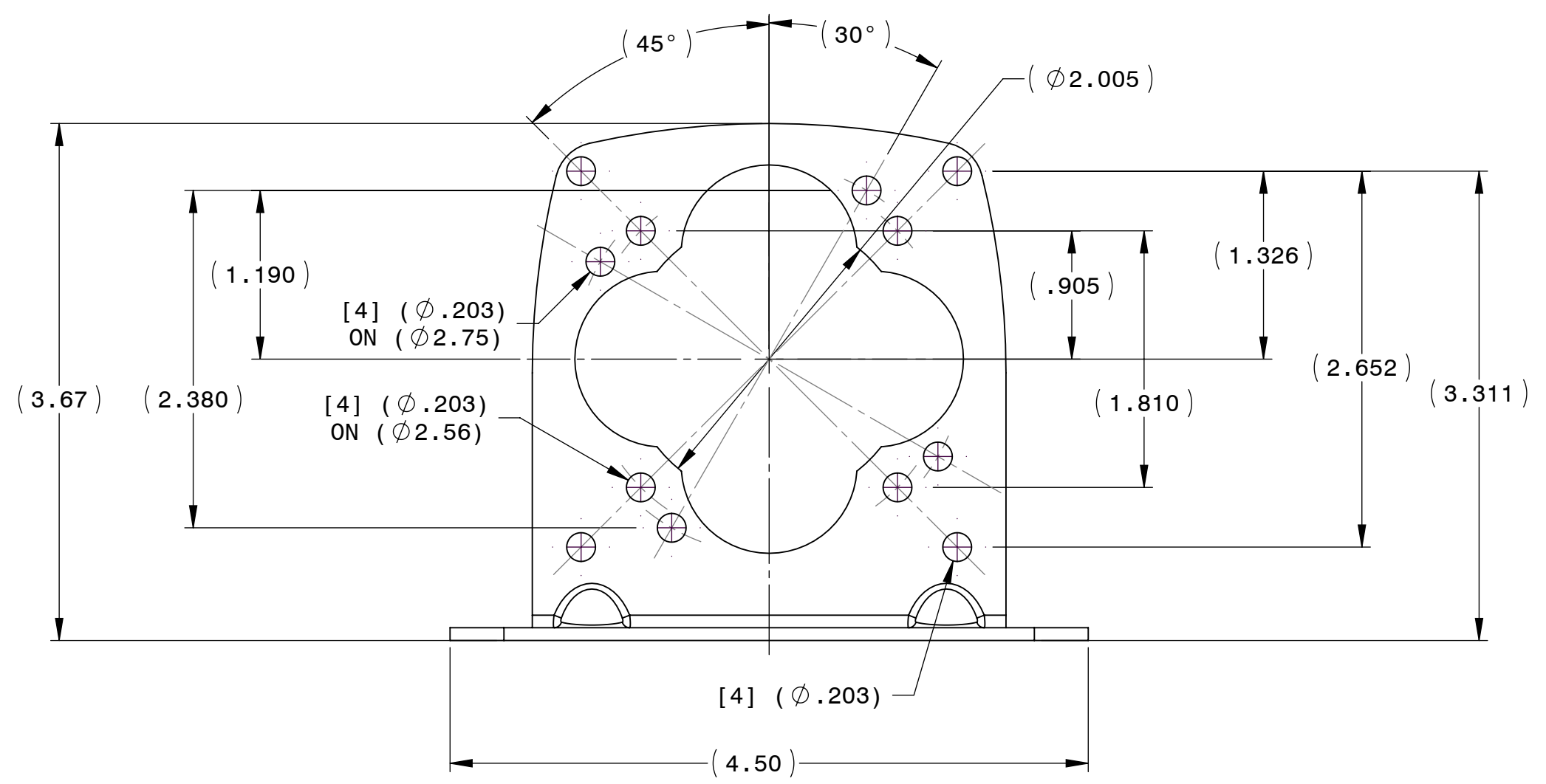
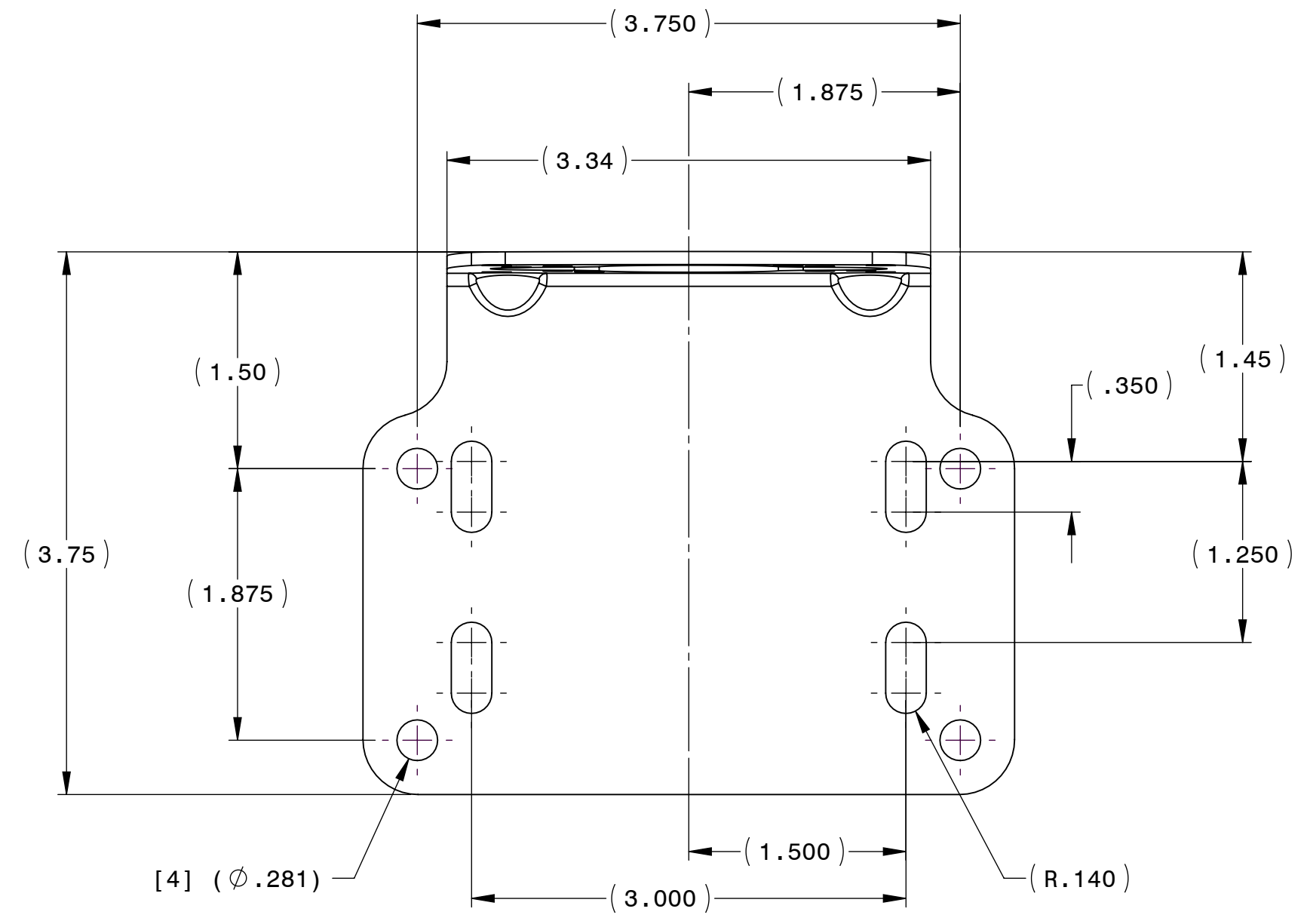

REPRESENTATIVE OF MODEL NUMBER(S):
 1968