

DESCRIPTION:
MOTOR 33A3FPM

SHEET:	1/1	UNLESS OTHERWISE SPECIFIED:
SCALE:	1:2	UNITS ARE IN INCHES [mm]
C		TOLERANCES: .XX:±.01 .XXX:±.005
		ANGLES: X°:±3° X.X°:±0.5°

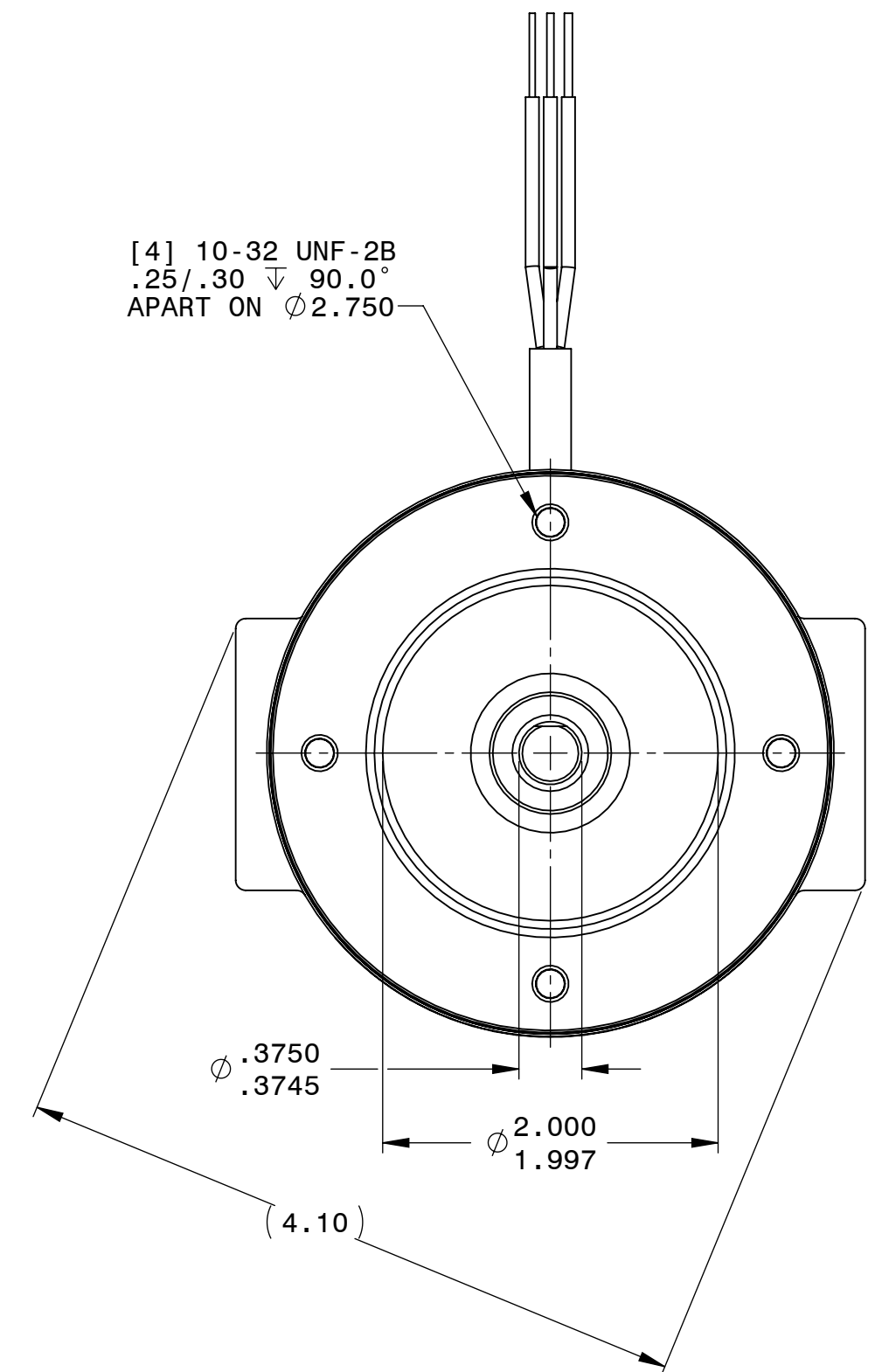

REPRESENTATIVE OF MODEL NUMBER(S):
6424 6434

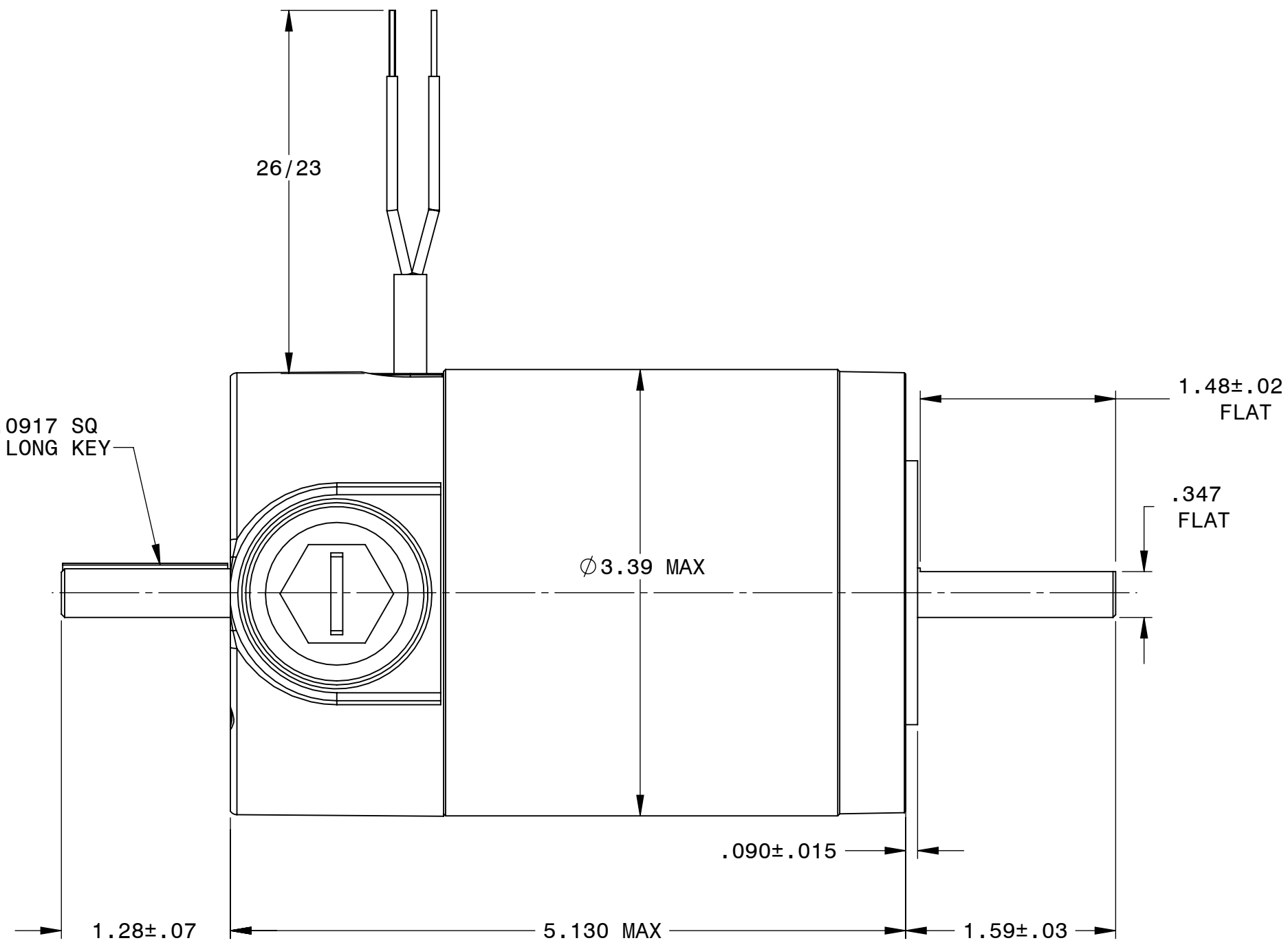
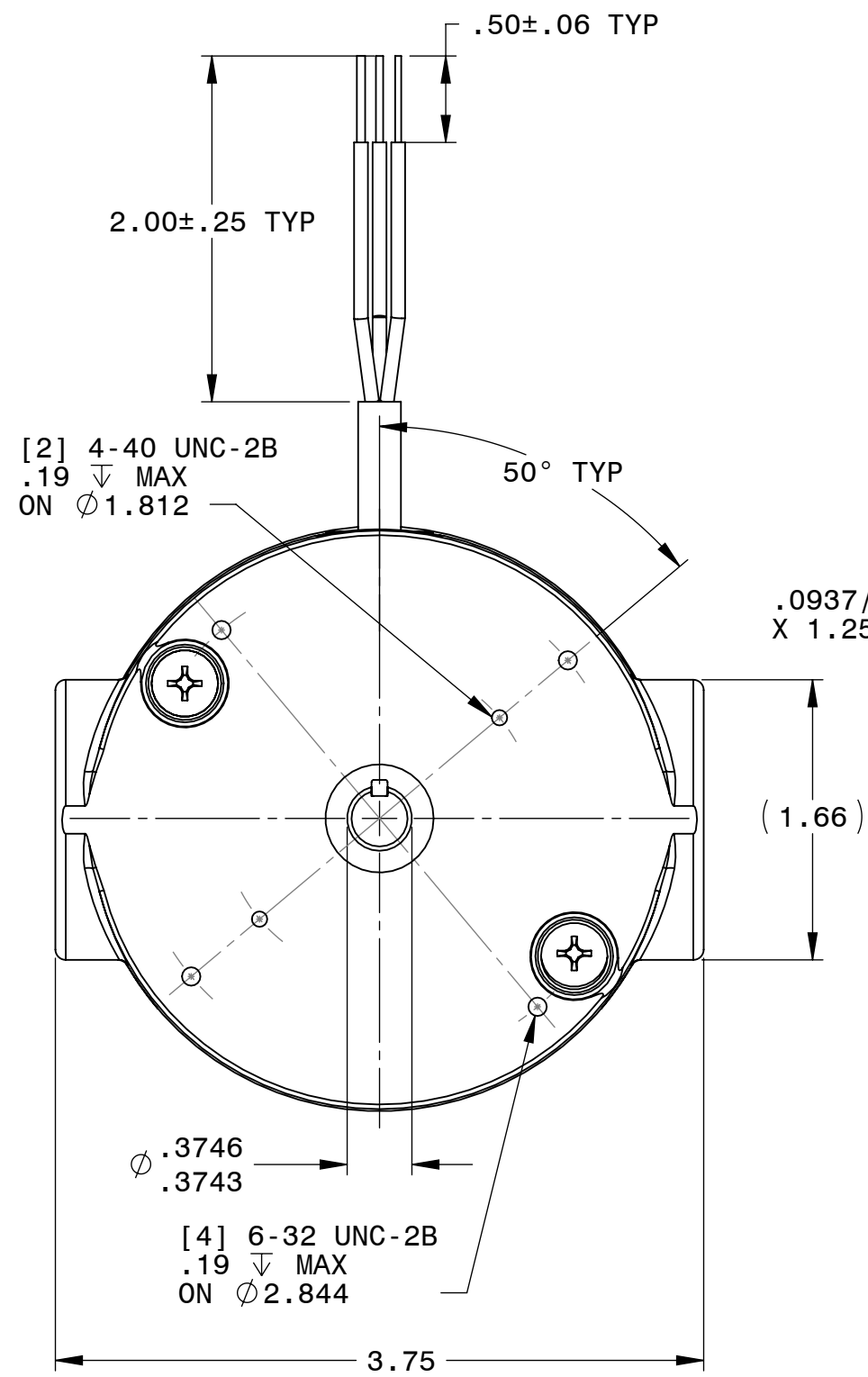