

DESCRIPTION: GEARMOTOR 33A3FEPM-Z2	
SHEET: 1/1	UNLESS OTHERWISE SPECIFIED:
SCALE: 1:1	UNITS ARE IN INCHES [mm]
C	TOLERANCES: .XX:±.01 .XXX:±.005
	ANGLES: X°:±3° X.X°:±0.5°

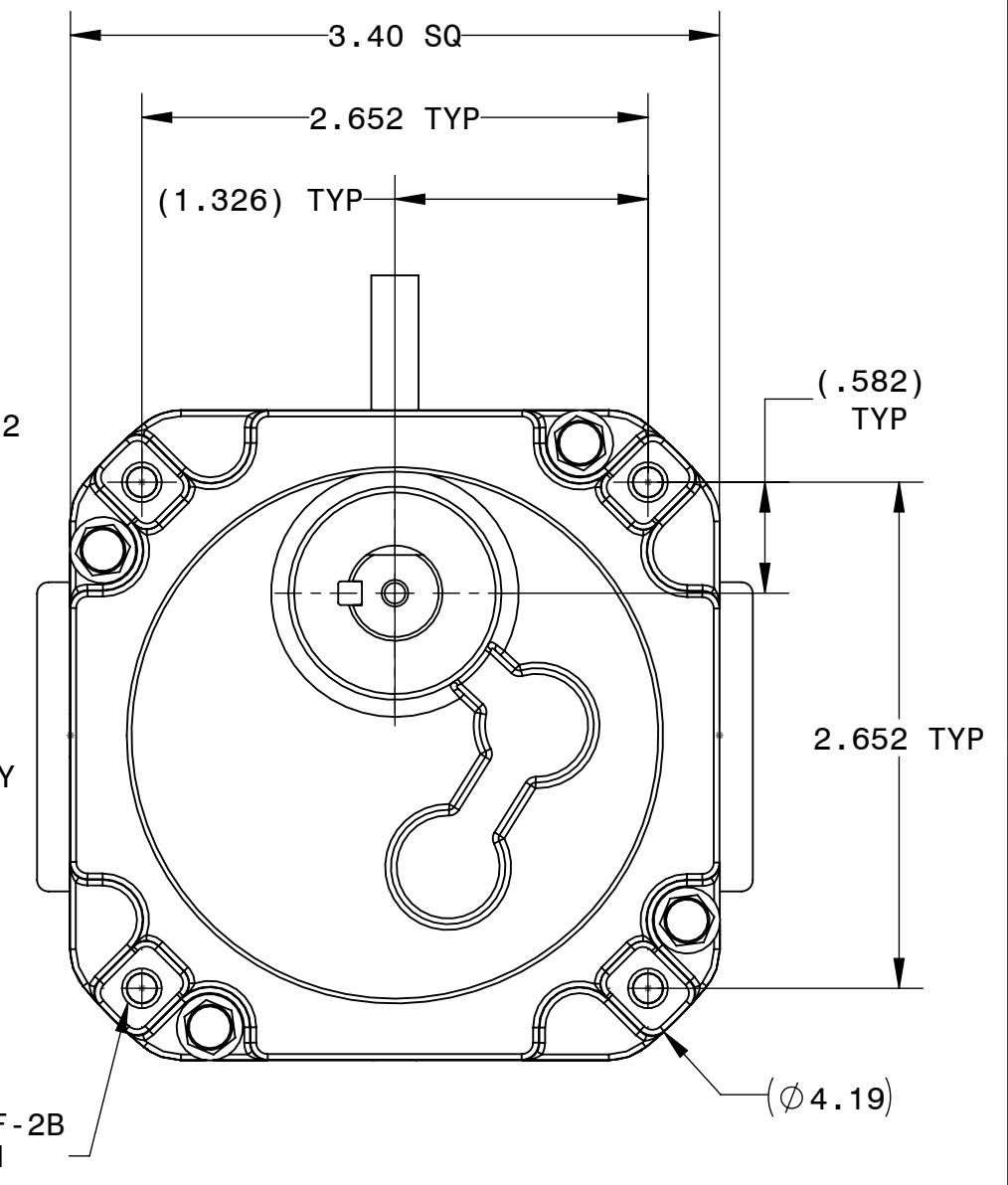
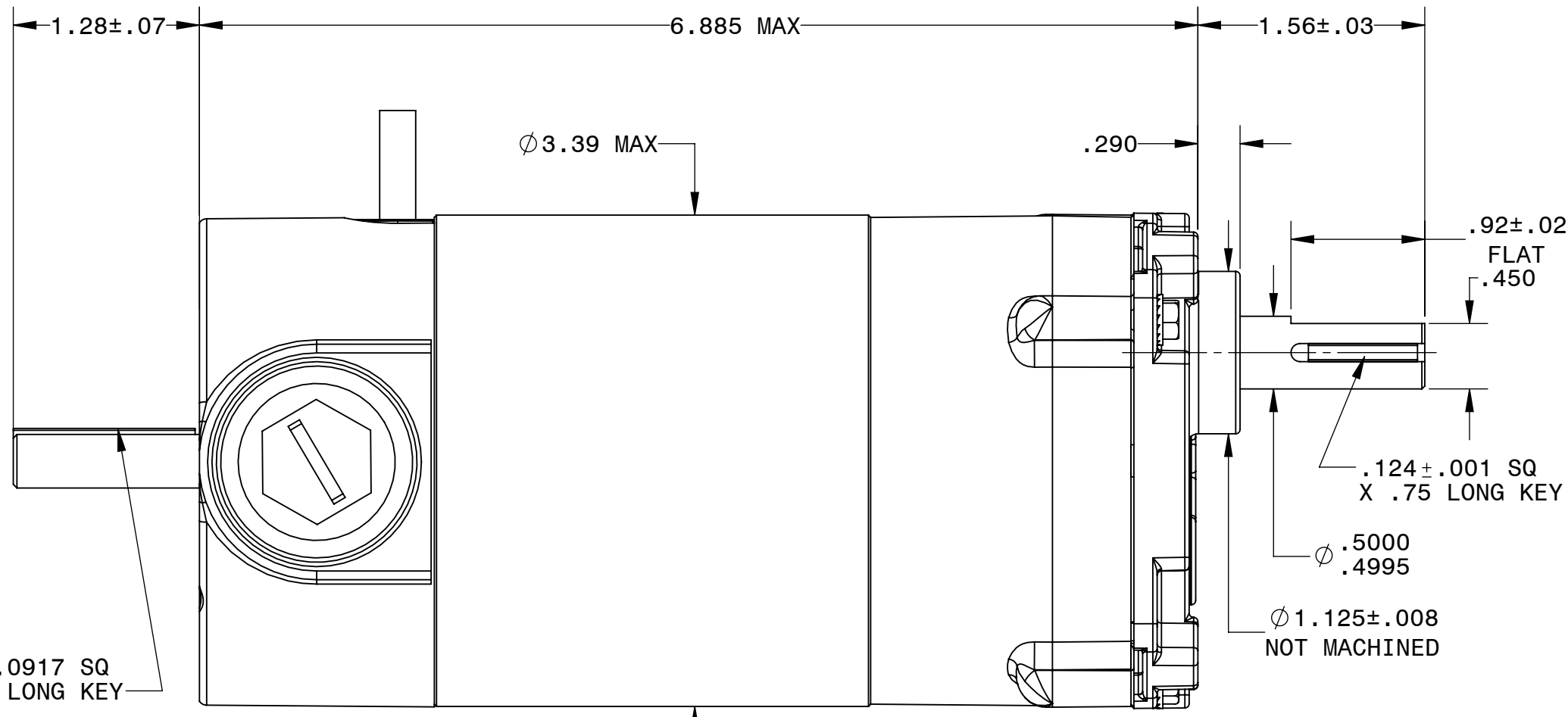
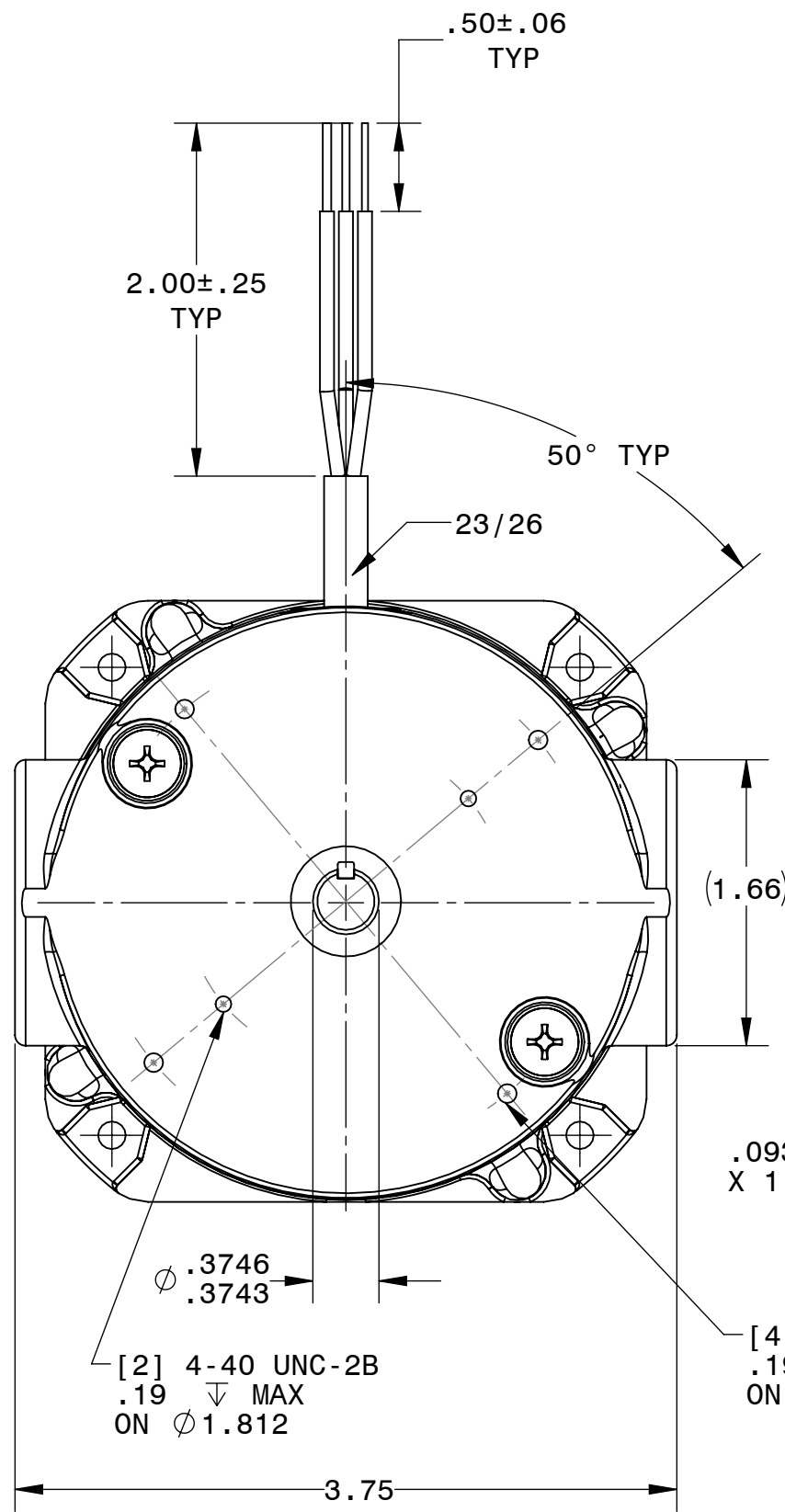

[4] 10-32 UNF-2B
X .377 ∇ MIN

REPRESENTATIVE OF MODEL NUMBER(S):

6565 6566 6567 6965 6966 6967

