

DESCRIPTION: GEARMOTOR 42A5FEPM-5N	
SHEET: 1/1	UNLESS OTHERWISE SPECIFIED:
SCALE: 3:4	UNITS ARE IN INCHES [mm]
C	TOLERANCES: .XX:±.01 .XXX:±.005
	ANGLES: X°:±3° X.X°:±0.5°

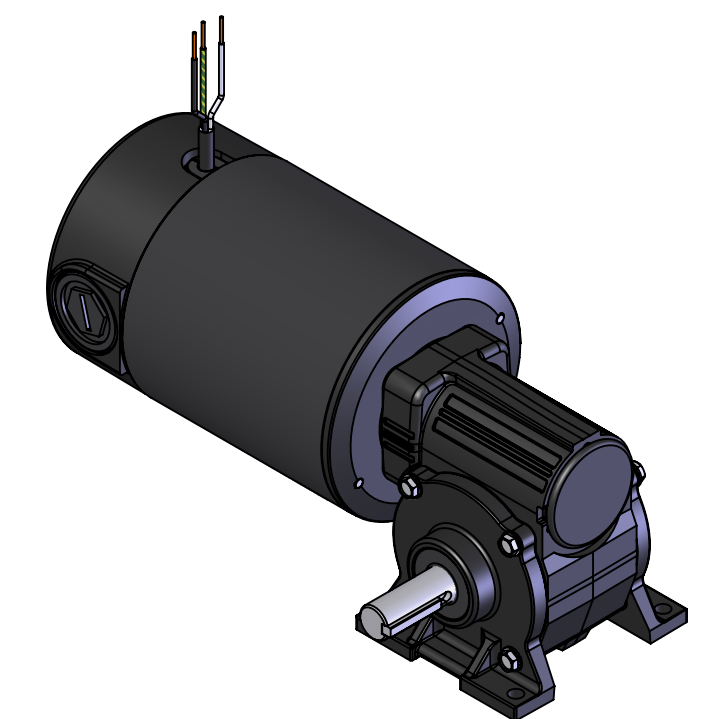
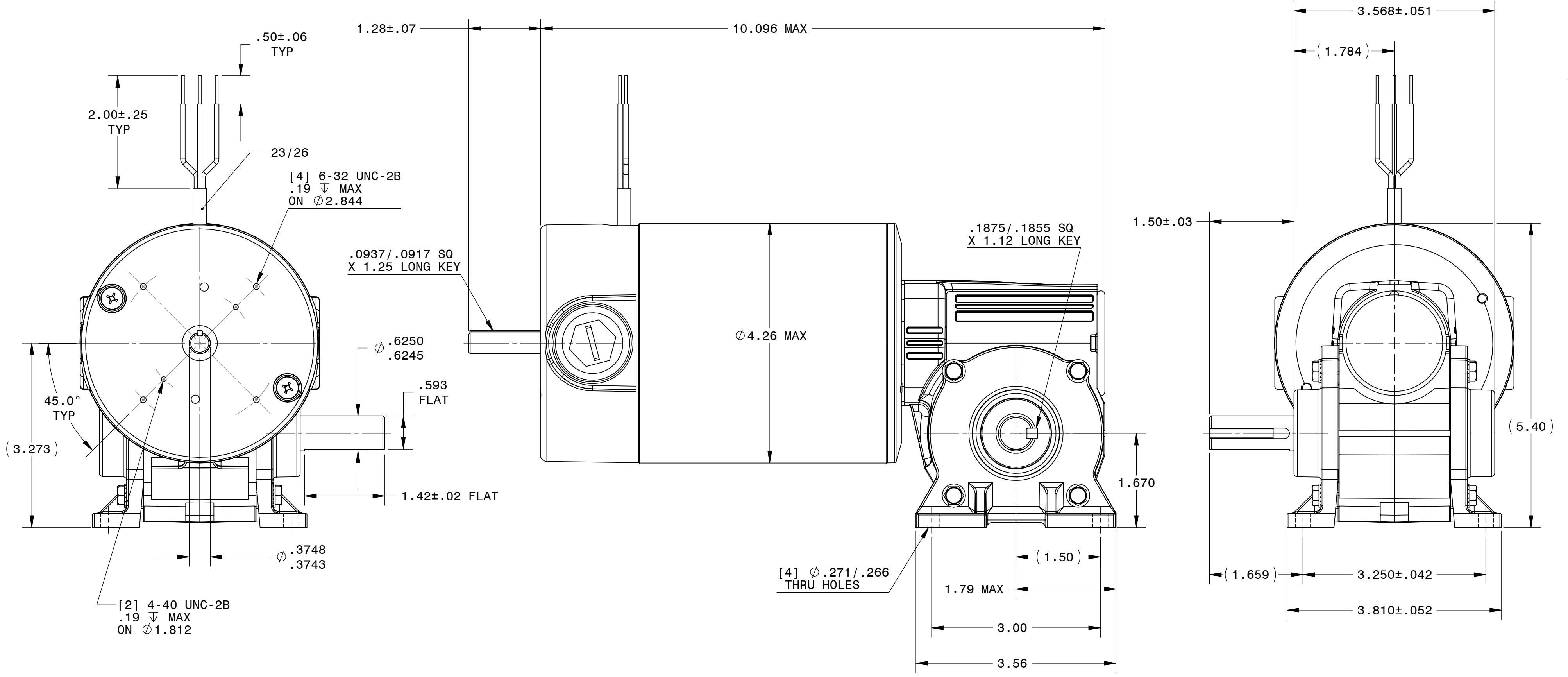

REPRESENTATIVE OF MODEL NUMBER(S):  
4534 4535 4536 4537 4538 5834 5835 5836 5837 5838