

DESCRIPTION:
GEARMOTOR 42A7FEPM-CG

SHEET: 1/1
SCALE: 3:4
C
UNLESS OTHERWISE SPECIFIED:
UNITS ARE IN INCHES [mm]
TOLERANCES: .XX:±.01 .XXX:±.005
ANGLES: X°:±3° X.X°:±0.5°

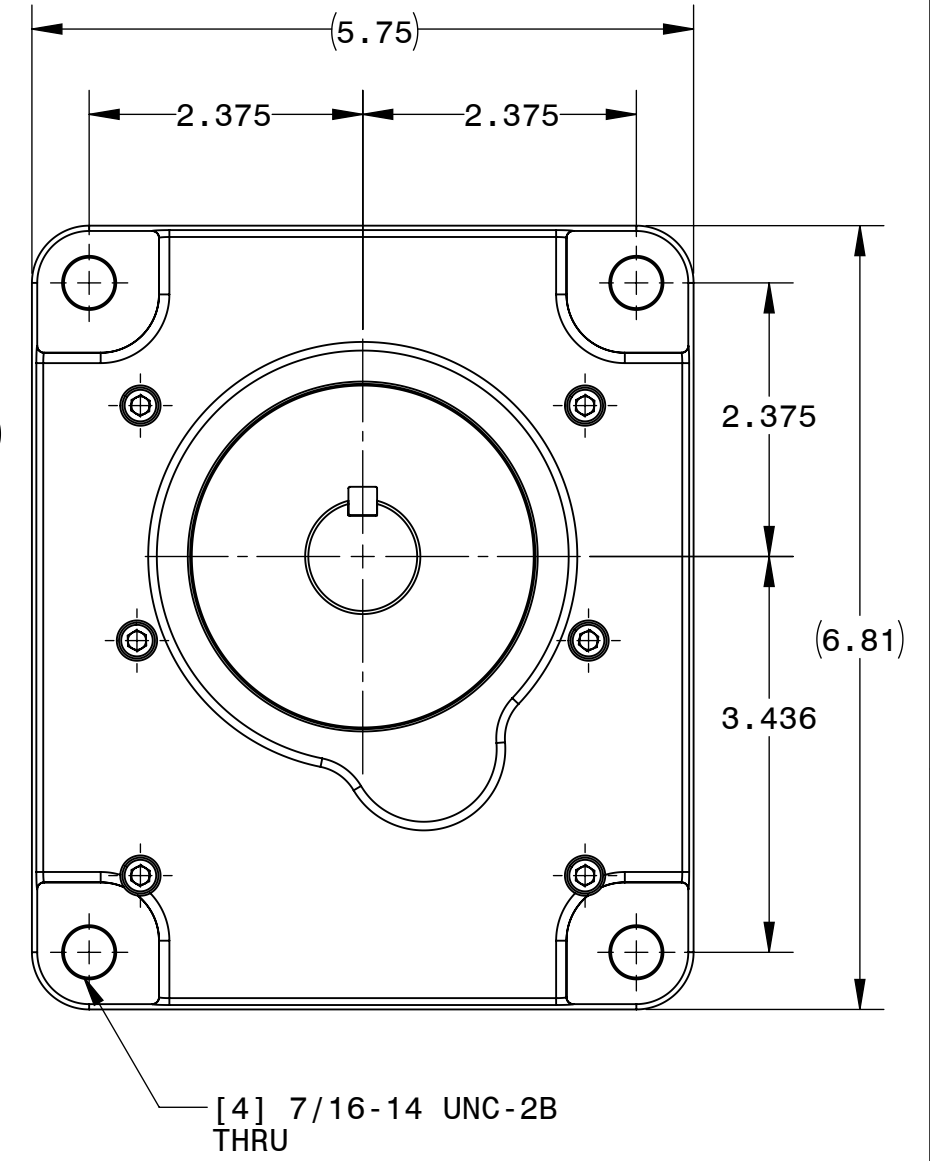
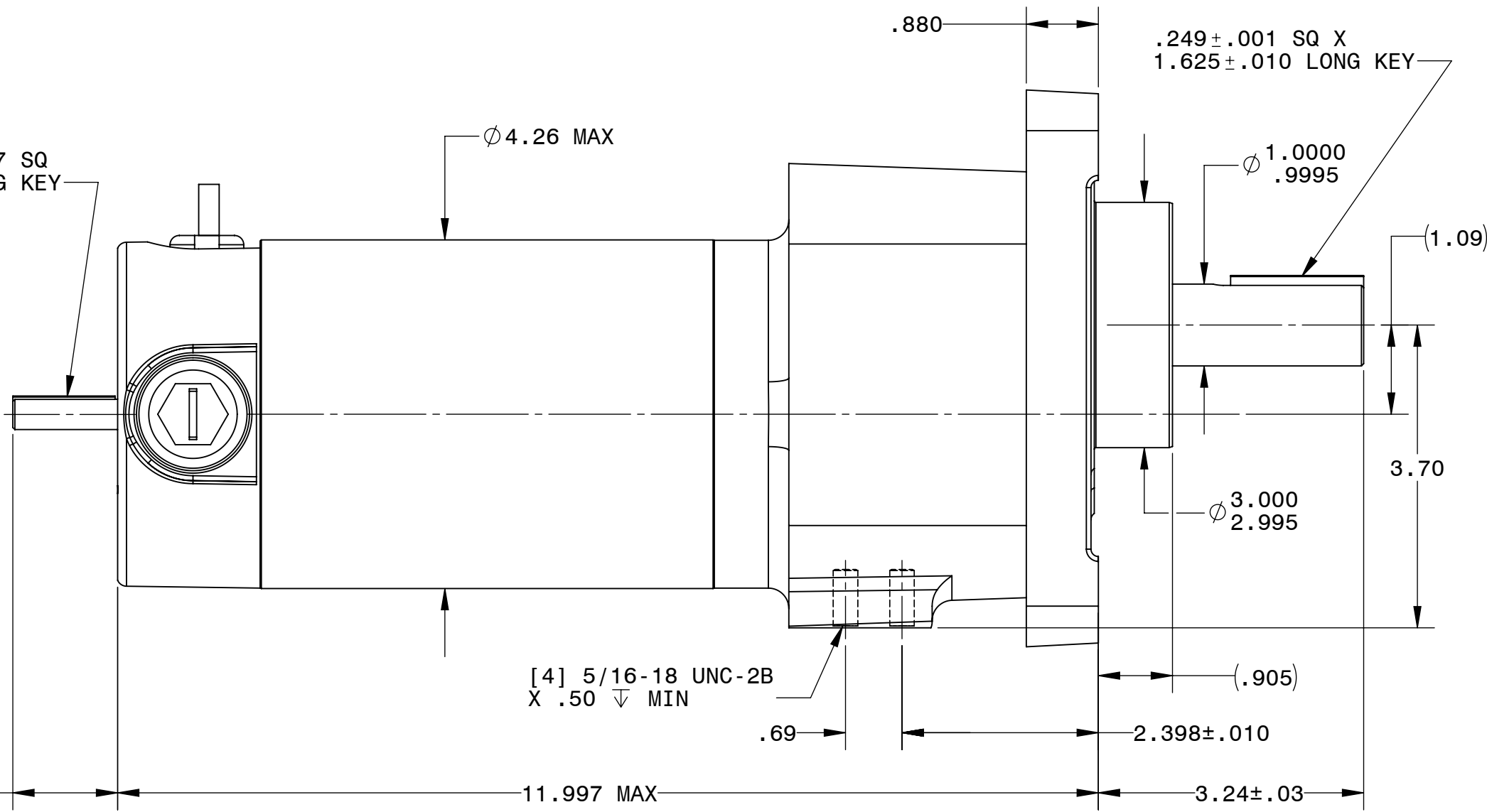
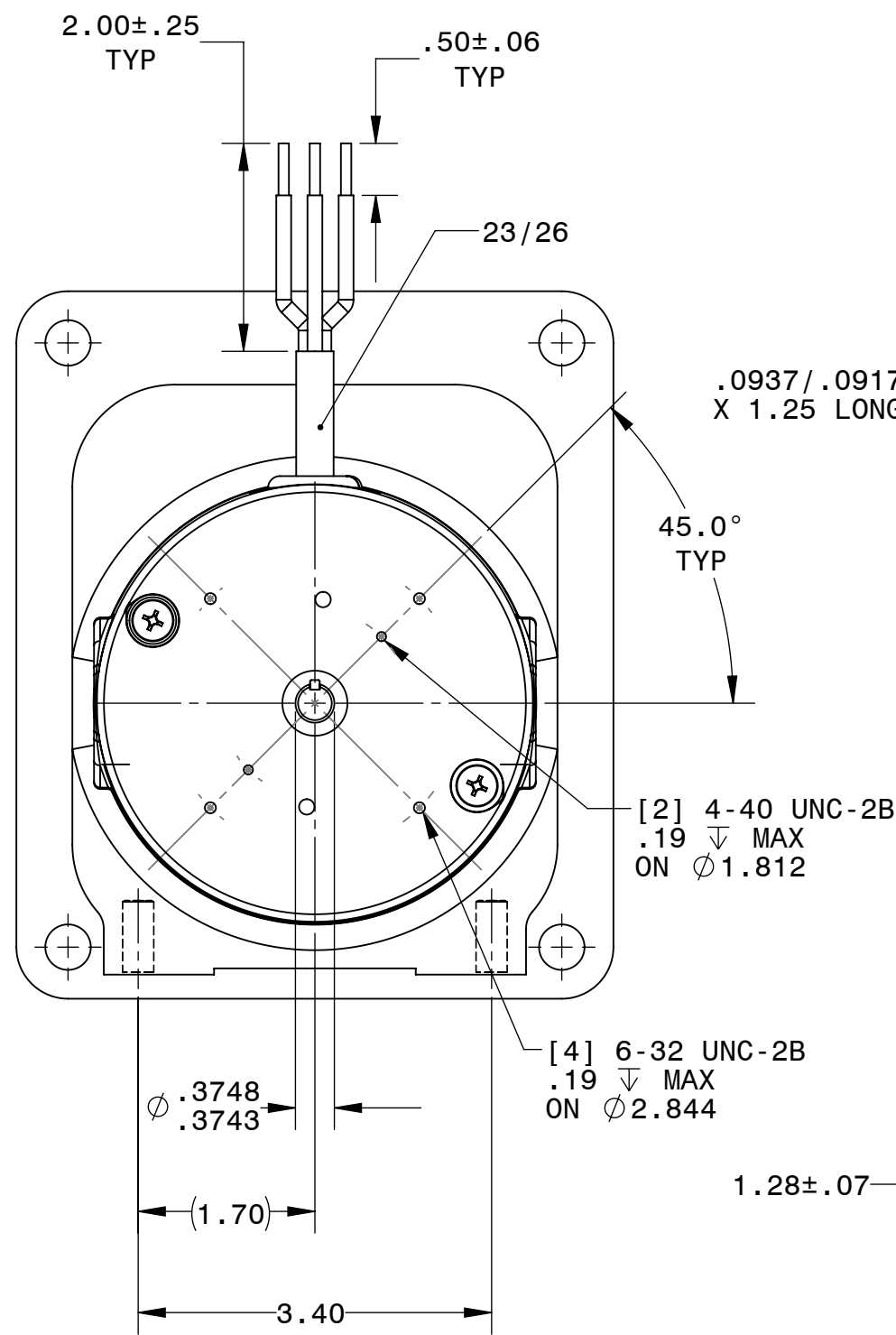

REPRESENTATIVE OF MODEL NUMBER(S):

4882 4883 4884 4885 4886

