

BODINE ELECTRIC COMPANY

PART NO./REV: INFM0378 A



DESCRIPTION:
KIT ACCESSORY SHAFT GB/H GEARMOTOR
Ø.750 X 2.38 EXTENSION

SHEET: 1/1	UNLESS OTHERWISE SPECIFIED:
SCALE: 1:1	UNITS ARE IN INCHES [mm]
B	TOLERANCES: .XX:±.01 .XXX:±.005 ANGLES: X°:±3° X.X°:±0.5°

- NOTES:
 1. MATERIAL: 316 STAINLESS STEEL
 2. ITEMS SUPPLIED WITH SHAFT
 KEYS: [2] STAINLESS STEEL.1875 SQ X 1.62 LONG
 THRUST WASHER: [1] ø1.23 OD X ø.757 ID X .0615 THICK
 RETAINING RINGS: [2] ROTOR CLIP P/N BSH-75 (1 SPARE)

SHAFT KIT INSTALLED

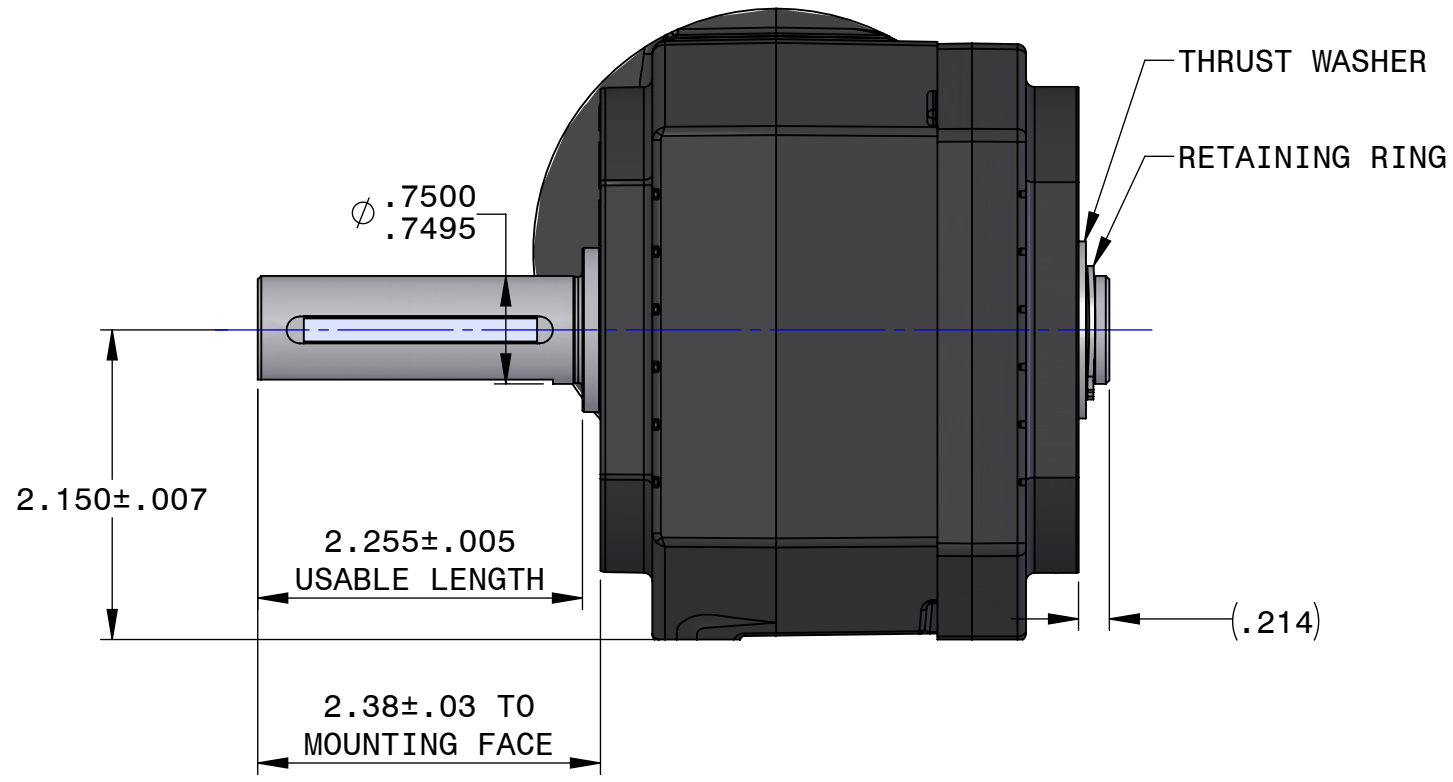

SHAFT DIMENSIONS

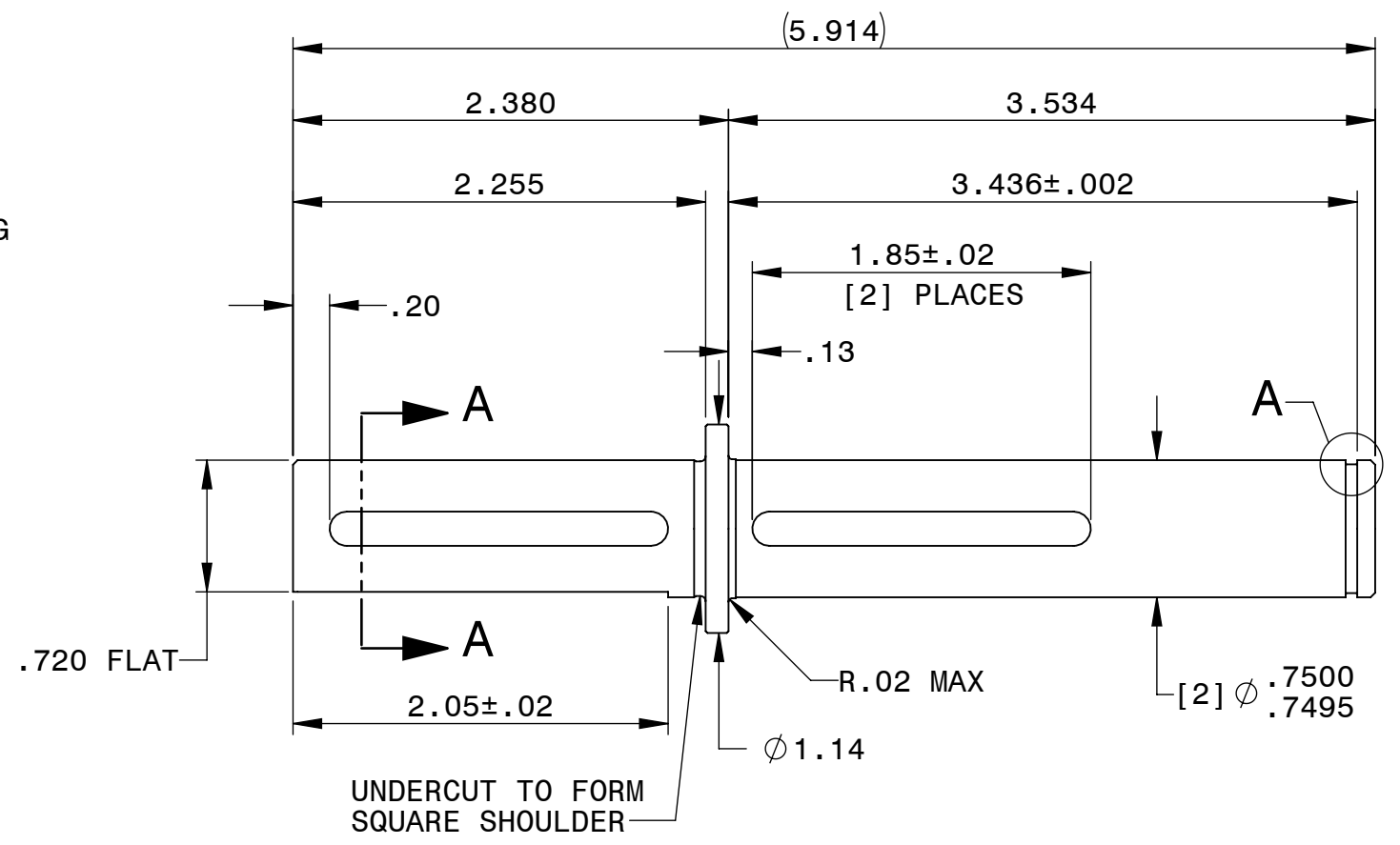

REPRESENTATIVE OF MODEL NUMBER(S):
0917

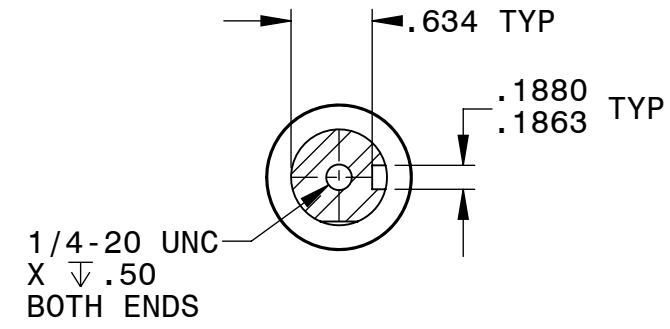

SECTION A-A
SCALE 1 : 1.5

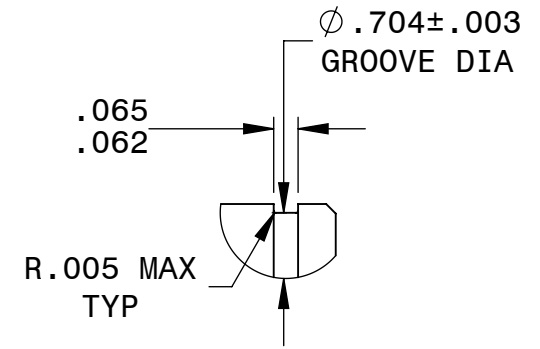

DETAIL A

