

NOTES:

- 1. FLANGE MATERIAL: ALUMINUM
- 2. ITEMS SUPPLIED WITH FLANGE
SCREWS: [4] STEEL 10-32 X .625 LONG

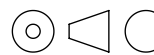

DESCRIPTION:
KIT ACCESSORY FLANGE 60P Ø.500
SHAFT

SHEET: 1/1	UNLESS OTHERWISE SPECIFIED: UNITS ARE IN INCHES [mm]
SCALE: 1:1	TOLERANCES: .XX:±.01 .XXX:±.005
A	ANGLES: X°:±3° X.X°:±0.5°

B

B

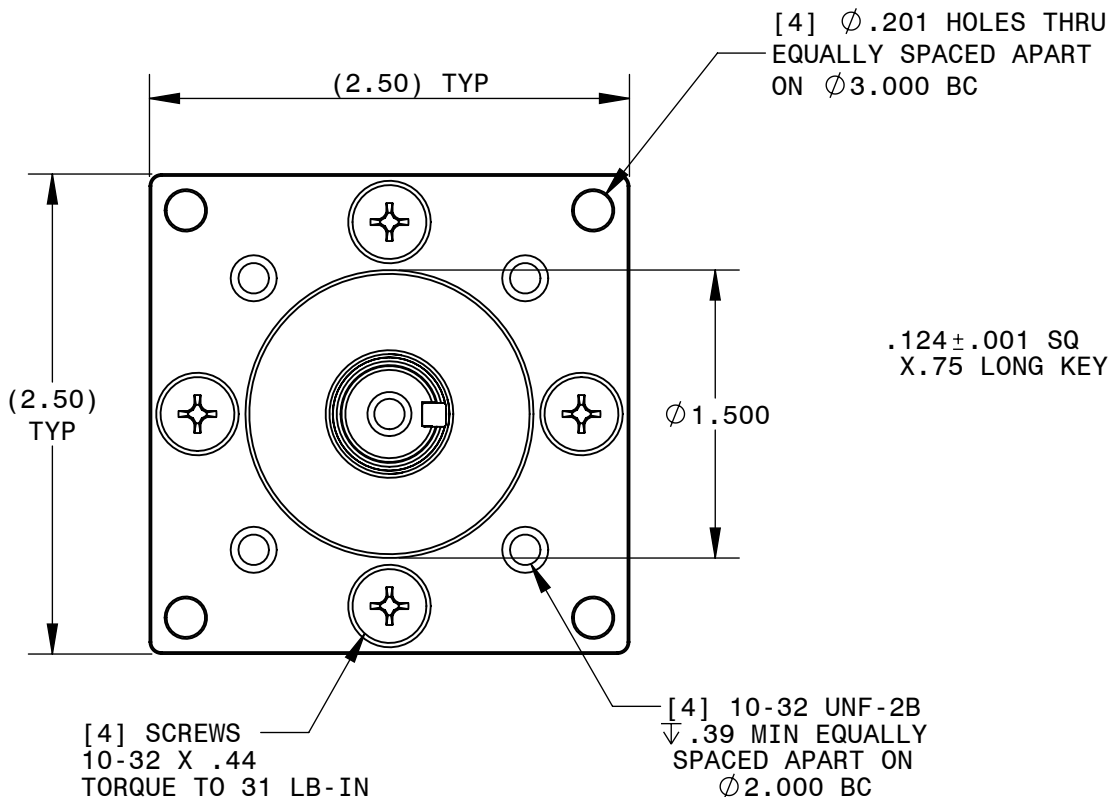

.124±.001 SQ
X.75 LONG KEY

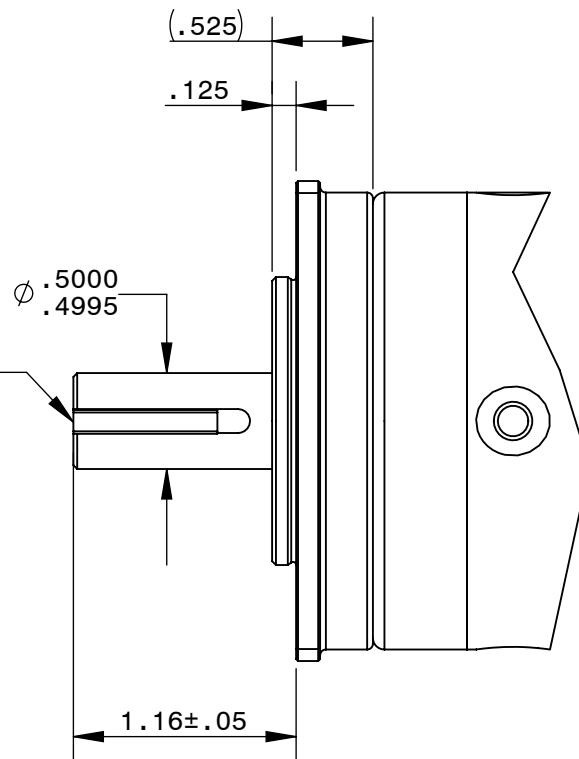

REPRESENTATIVE OF MODEL NUMBER(S):
0960

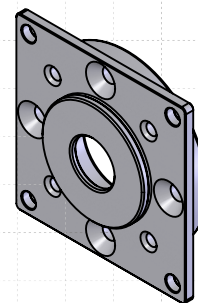

A

A