

NOTES:

- 1. FLANGE MATERIAL: ALUMINUM
- 2. ITEMS SUPPLIED WITH FLANGE
SCREWS: [4] STEEL M5 X 0.8 X 16 LONG

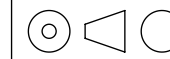

DESCRIPTION:
KIT ACCESSORY FLANGE 60P Ø14mm
SHAFT

SHEET:
1/1
SCALE:
1:1
UNLESS OTHERWISE SPECIFIED:
UNITS ARE IN mm [INCHES]
ANGLES: X°:±3° X.X°:±0.5°

A

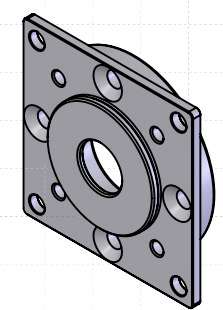
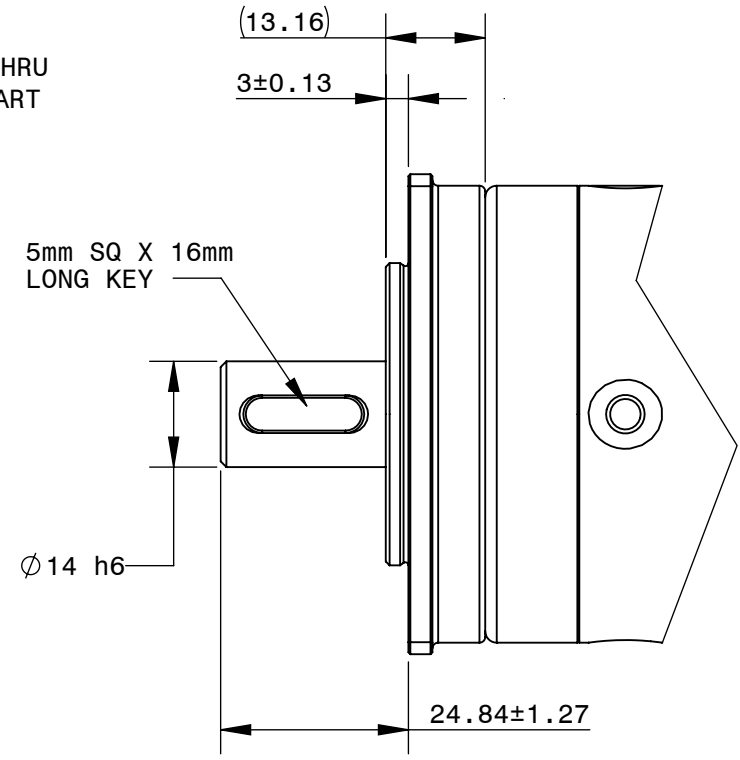
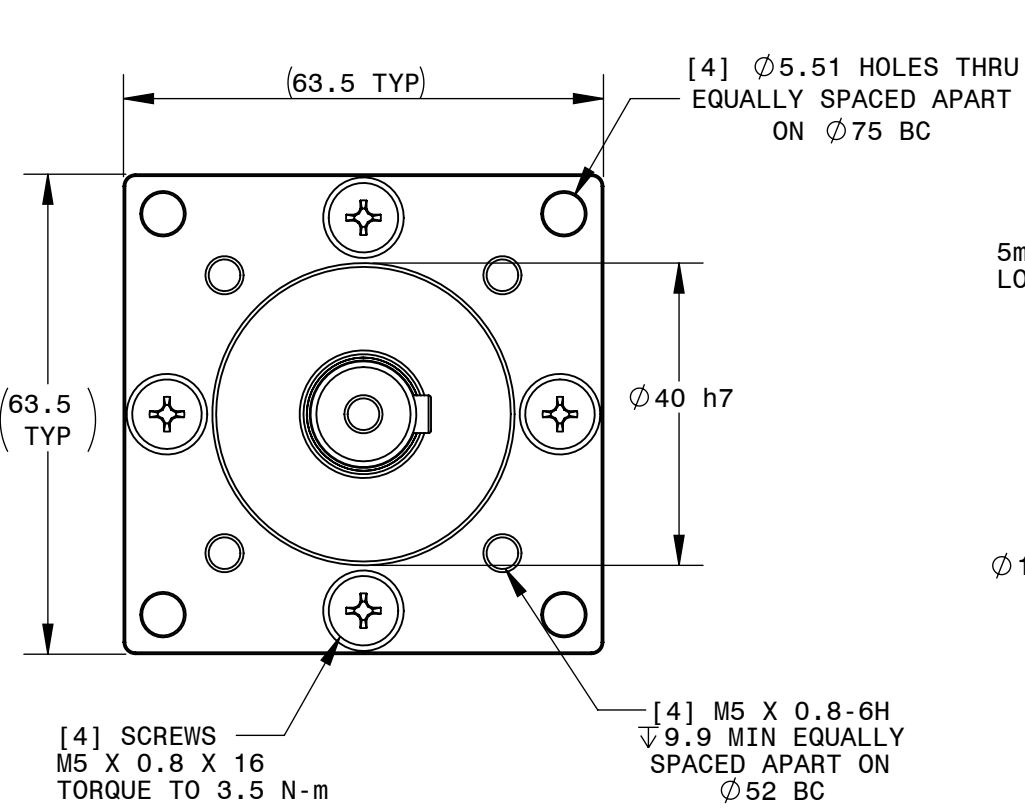

REPRESENTATIVE OF MODEL NUMBER(S):

0961