

BODINE ELECTRIC COMPANY

PART NO./REV: INFM0405 A

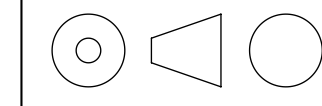

DESCRIPTION: GEARMOTOR 22B4FEBL-60P1	
SHEET: 1/1	UNLESS OTHERWISE SPECIFIED:
SCALE: 1:1	UNITS ARE IN INCHES [mm]
C	TOLERANCES: .XX:±.01 .XXX:±.005
	ANGLES: X°:±3° X.X°:±0.5°

- NOTES:
 1. SOME COMPONENTS REMOVED FROM VIEWS FOR CLARITY PURPOSES.
 2. REMOVE ENCODER CAP TO ACCESS ENCODER MOUNTING PROVISIONS.

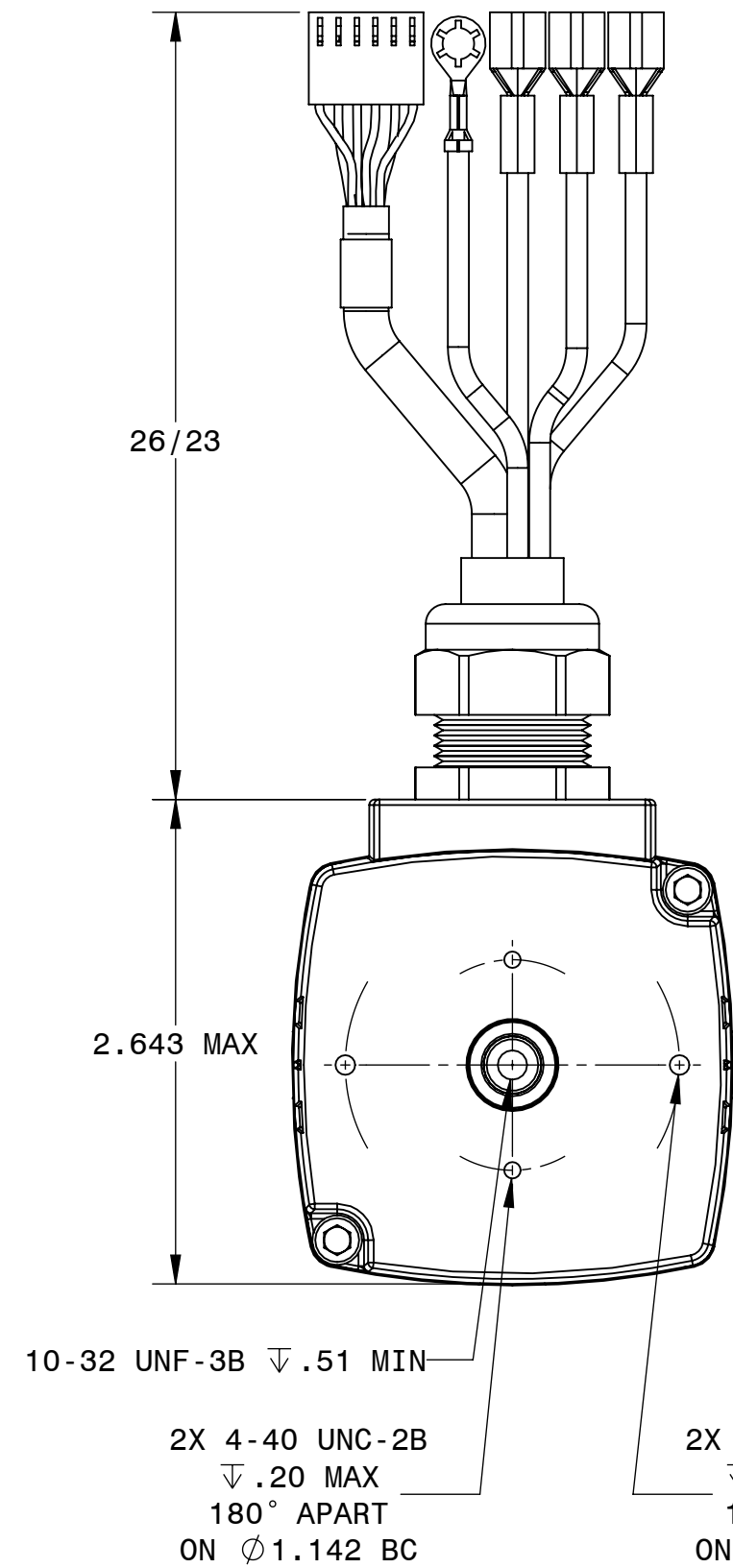

FACTORY INSTALLED ENCODER ACCESS CAP

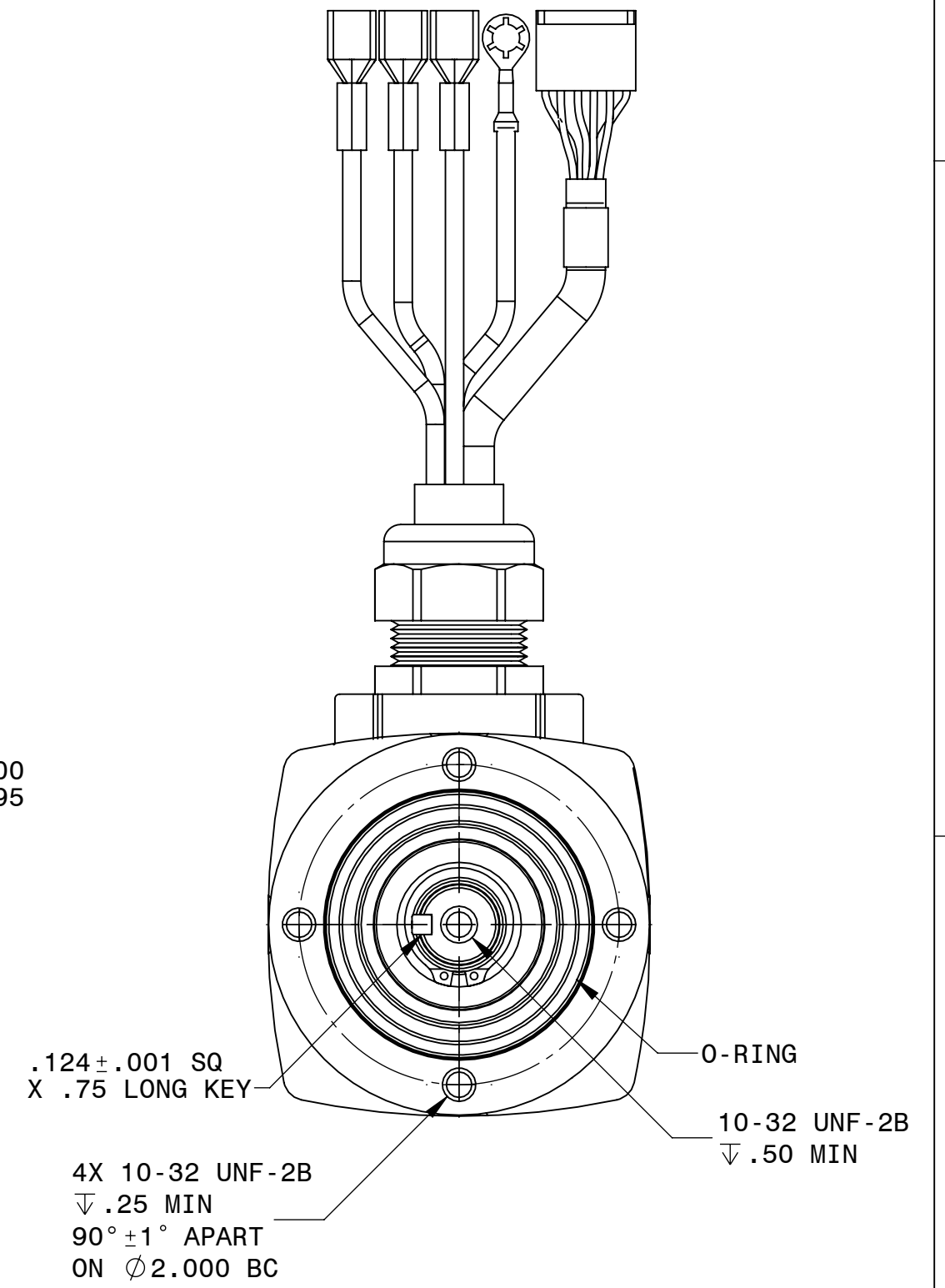
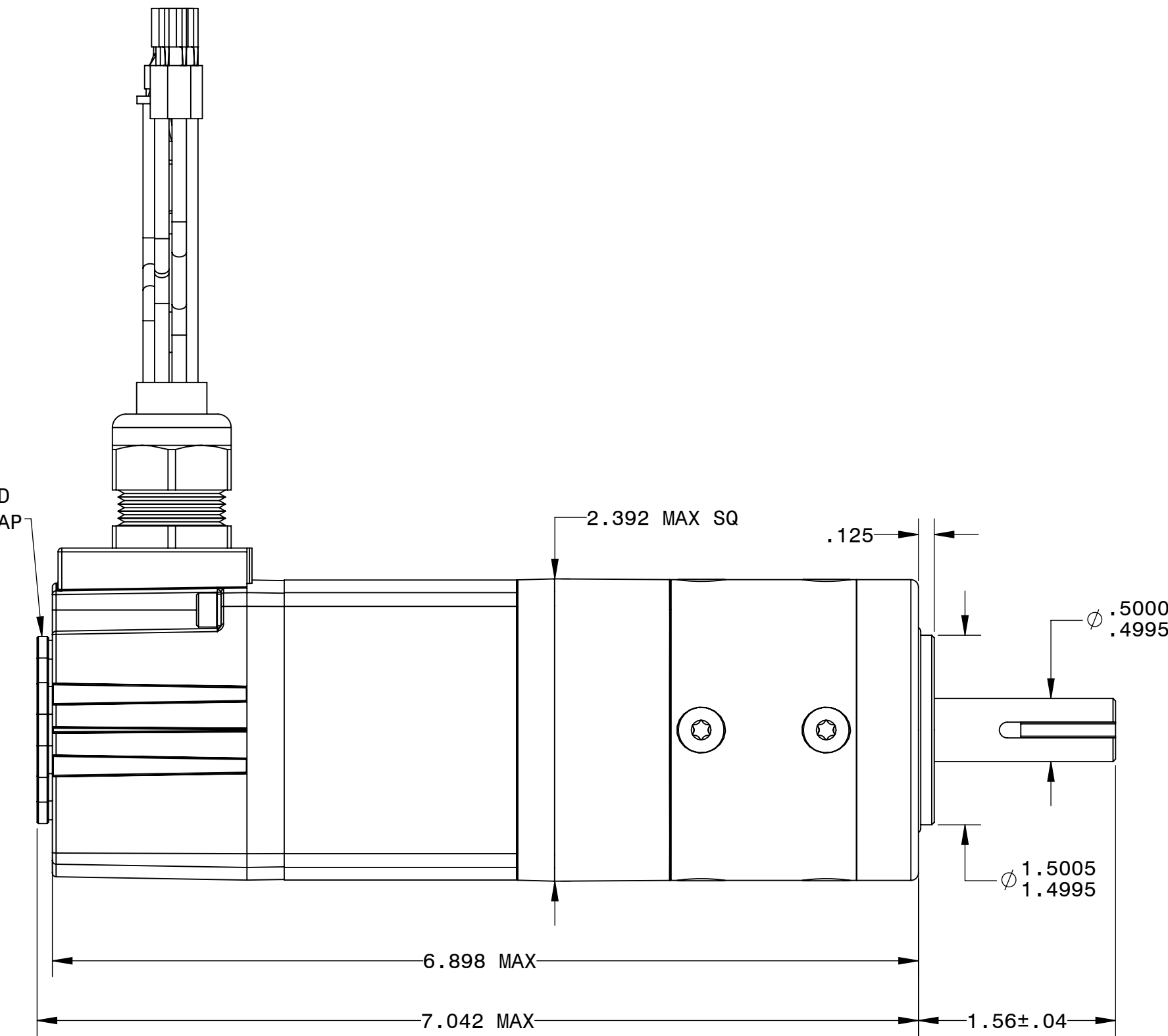

REPRESENTATIVE OF MODEL NUMBER(S):
7022 7021

