

Reversing motor starter Size 00 Single phase, 2 pole Amb
 compensate bimetal OLrelay Contactor amp rating 9Amp Non-
 combination type Enclosure NEMA type 1 Indoor general purpose
 use



Figure similar

| General technical data | |
|--|--------------------------|
| Weight [lb] | 23 lb |
| Height x Width x Depth [in] | 20 × 12 × 8 in |
| Protection against electrical shock | NA for enclosed products |
| Installation altitude [ft] at height above sea level maximum | 6560 ft |
| Ambient temperature [°F] during storage | -22 ... +149 °F |
| Ambient temperature [°F] during operation | -4 ... +104 °F |
| Ambient temperature during storage | -30 ... +65 °C |
| Ambient temperature during operation | -20 ... +40 °C |
| Country of origin | USA |
| Horsepower ratings | |
| Yielded mechanical performance [hp] for single-phase AC motor | |
| <ul style="list-style-type: none"> at 115 V rated value | 0.33 hp |
| Contactor | |
| Number of NO contacts for main contacts | 2 |

| | |
|---|----------|
| Operating voltage for main current circuit at AC at 60 Hz maximum | 240 V |
| Operating current at AC at 600 V rated value | 9 A |
| Mechanical service life (switching cycles) of the main contacts typical | 10000000 |

Auxiliary contact

| | |
|---|-------------------------------------|
| Number of NC contacts at contactor for auxiliary contacts | 0 |
| Number of NO contacts at contactor for auxiliary contacts | 1 |
| Number of total auxiliary contacts maximum | 8 |
| Contact rating of auxiliary contacts of contactor according to UL | 10A@600VAC (A600), 5A@600VDC (P600) |

Coil

| | |
|--|---------------|
| Type of voltage of the control supply voltage | AC |
| Control supply voltage | |
| • at DC rated value | 0 ... 0 V |
| • at AC at 60 Hz rated value | 220 ... 240 V |
| • at AC at 50 Hz rated value | 190 ... 220 V |
| Holding power at AC minimum | 8.6 W |
| Apparent pick-up power of magnet coil at AC | 218 V·A |
| Apparent holding power of magnet coil at AC | 25 V·A |
| Operating range factor control supply voltage rated value of magnet coil | 0.85 ... 1.1 |
| Percental drop-out voltage of magnet coil related to the input voltage | 50 % |
| Switch-on delay time | 19 ... 29 ms |
| Off-delay time | 10 ... 24 ms |

Overload relay

| | |
|---|----------------------|
| Product function | |
| • Overload protection | Yes |
| • Test function | Yes |
| • External reset | Yes |
| Reset function | Manual and automatic |
| Adjustment range of thermal overload trip unit | 0.85 ... 1.15 |
| Number of NC contacts of auxiliary contacts of overload relay | 1 |
| Number of NO contacts of auxiliary contacts of overload relay | 0 |
| Operating current of auxiliary contacts of overload relay | |
| • at AC at 600 V | 5 A |
| • at DC at 250 V | 5 A |

| | |
|--|------------------------------------|
| Contact rating of auxiliary contacts of overload relay according to UL | 5A@600VAC (B600), 5A@250VDC (P300) |
|--|------------------------------------|

Enclosure

| | |
|---|----------------------------|
| Degree of protection NEMA rating of the enclosure | NEMA Type 1 |
| Design of the housing | Indoor general purpose use |

Mounting/wiring

| | |
|--|---|
| Mounting position | Vertical |
| (mounting type) | Surface mounting and installation |
| Type of electrical connection for supply voltage line-side | Screw-type terminals |
| Tightening torque [lbf-in] for supply | 20 ... 20 lbf-in |
| Temperature of the conductor for supply maximum permissible | 75 °C |
| Material of the conductor for supply | AL or CU |
| Type of electrical connection for load-side outgoing feeder | Screw-type terminals |
| Tightening torque [lbf-in] for load-side outgoing feeder | 35 ... 50 lbf-in |
| Type of electrical connection of magnet coil | Screw-type terminals |
| Tightening torque [lbf-in] at magnet coil | 5 ... 12 lbf-in |
| Type of connectable conductor cross-sections of magnet coil at AWG conductors single or multi-stranded | 2x (16 ... 12 AWG) |
| Temperature of the conductor at magnet coil maximum permissible | 75 °C |
| Material of the conductor at magnet coil | CU |
| Type of electrical connection for auxiliary contacts | Screw-type terminals |
| Tightening torque [lbf-in] at contactor for auxiliary contacts | 10 ... 15 lbf-in |
| Type of connectable conductor cross-sections at contactor at AWG conductors for auxiliary contacts single or multi-stranded | 1x (12 AWG), 2x (16 ... 14 AWG), 2x (18 ... 16 AWG) |
| Temperature of the conductor at contactor for auxiliary contacts maximum permissible | 75 °C |
| Material of the conductor at contactor for auxiliary contacts | CU |
| Type of electrical connection at overload relay for auxiliary contacts | Screw-type terminals |
| Tightening torque [lbf-in] at overload relay for auxiliary contacts | 5 ... 12 lbf-in |
| Type of connectable conductor cross-sections at overload relay at AWG conductors for auxiliary contacts single or multi-stranded | 2x (16 ... 12 AWG) |
| Temperature of the conductor at overload relay for auxiliary contacts maximum permissible | 75 °C |

| | |
|--|---|
| Material of the conductor at overload relay for auxiliary contacts | CU |
| Short-circuit current rating | |
| Design of the fuse link for short-circuit protection of the main circuit required | 10kA@600V (Class H or K); 100kA@600V (Class R or J) |
| Design of the short-circuit trip | Thermal magnetic circuit breaker |
| Maximum short-circuit current breaking capacity (Icu) | |
| <ul style="list-style-type: none"> • at 240 V • at 480 V • at 600 V | <ul style="list-style-type: none"> 14 kA 10 kA 10 kA |

Further information

Industrial Controls - Product Overview (Catalogs, Brochures,...)

www.usa.siemens.com/iccatalog

Industry Mall (Online ordering system)

<https://mall.industry.siemens.com/mall/en/us/Catalog/product?mfb=US2:22BP12BG81>

Service&Support (Manuals, Certificates, Characteristics, FAQs,...)

<https://support.industry.siemens.com/cs/US/en/ps/US2:22BP12BG81>

Image database (product images, 2D dimension drawings, 3D models, device circuit diagrams, EPLAN macros, ...)

http://www.automation.siemens.com/bilddb/cax_de.aspx?mfb=US2:22BP12BG81&lang=en

Certificates/approvals

<https://support.industry.siemens.com/cs/US/en/ps/US2:22BP12BG81/certificate>



| LETTER | KNOCKOUT & CONDUIT SIZE |
|--------|---|
| A | %%C22.2 X %%C28.6 FOR 12.7 & 19 CONDUIT |
| B | %%C43.6 X %%C50 FOR 31.8 & 38.1 CONDUIT |
| C | %%C50 X %%C62.7 FOR 38.1 & 50.8 CONDUIT |

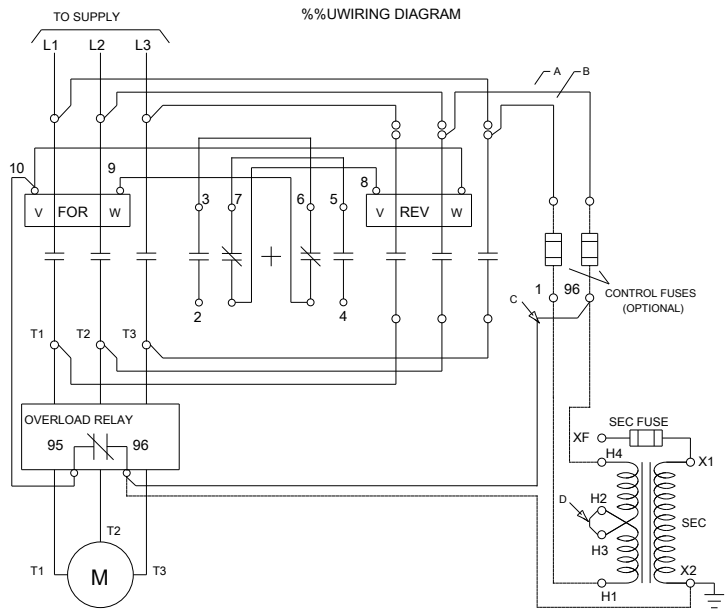
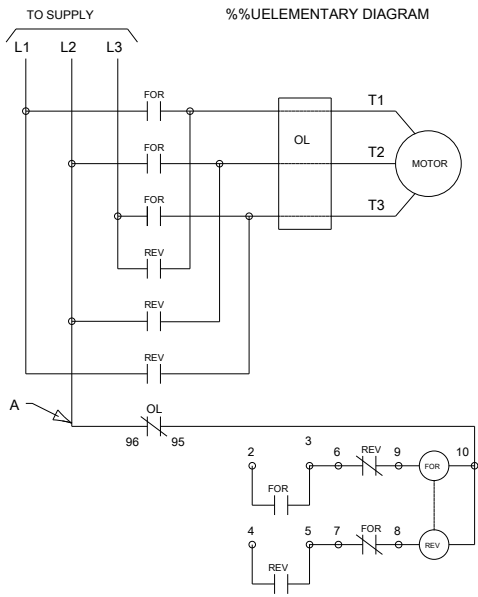

D46590003

last modified:

05/08/2019