

2-speed 3-phase motor starter Size 2 One winding consequent pole
 Constant or variable torque Solid-state overload relays Low SPD
 OLR range 13-52a High SPD OLR range 13-52a 220-240/440-
 480VAC 60HZ coil Encl. NEMA type 4X Fiberglass Water/dust tight
 noncorrosive



Figure similar

General technical data	
Weight [lb]	39 lb
Height x Width x Depth [in]	24 × 24 × 7 in
Protection against electrical shock	NA for enclosed products
Installation altitude [ft] at height above sea level maximum	6560 ft
Ambient temperature [°F] during storage	-22 ... +149 °F
Ambient temperature [°F] during operation	-4 ... +104 °F
Ambient temperature during storage	-30 ... +65 °C
Ambient temperature during operation	-20 ... +40 °C
Country of origin	USA

Horsepower ratings	
Yielded mechanical performance [hp] for three-phase AC motor	
<ul style="list-style-type: none"> • at 200/208 V rated value • at 220/230 V rated value • at 460/480 V rated value 	<p>10 hp</p> <p>15 hp</p> <p>25 hp</p>

- at 575/600 V rated value

25 hp

Contactors

Number of NO contacts for main contacts	6
Operating voltage for main current circuit at AC at 60 Hz maximum	600 V
Operating current at AC at 600 V rated value	45 A
Mechanical service life (switching cycles) of the main contacts typical	10000000

Auxiliary contact

Number of NC contacts at contactor for auxiliary contacts	2
Number of NO contacts at contactor for auxiliary contacts	2
Number of total auxiliary contacts maximum	7
Contact rating of auxiliary contacts of contactor according to UL	10A@600VAC (A600), 5A@600VDC (P600)

Coil

Type of voltage of the control supply voltage	AC
Control supply voltage	
<ul style="list-style-type: none"> • at DC rated value 	0 ... 0 V
<ul style="list-style-type: none"> • at AC at 60 Hz rated value 	220 ... 480 V
<ul style="list-style-type: none"> • at AC at 50 Hz rated value 	0 ... 0 V
Holding power at AC minimum	17.2 W
Apparent pick-up power of magnet coil at AC	436 V·A
Apparent holding power of magnet coil at AC	50 V·A
Operating range factor control supply voltage rated value of magnet coil	0.85 ... 1.1
Percental drop-out voltage of magnet coil related to the input voltage	50 %
Switch-on delay time	19 ... 29 ms
Off-delay time	10 ... 24 ms

Overload relay

Product function	
<ul style="list-style-type: none"> • Overload protection • Phase failure detection • Phase unbalance • Ground fault detection • Test function • External reset 	<p>Yes</p> <p>Yes</p> <p>Yes</p> <p>Yes</p> <p>Yes</p> <p>Yes</p>
Reset function	Manual, automatic and remote
Trip class	Class 5 / 10 / 20 (factory set) / 30
Adjustable pick-up value current of overload relay	

<ul style="list-style-type: none"> • for low rotational speed 	13 ... 52 A
<ul style="list-style-type: none"> • for high rotational speed 	13 ... 52 A
Trip time at phase-loss maximum	3 s
Relative repeat accuracy	1 %
Product feature Protective coating on printed-circuit board	Yes
Number of NC contacts of auxiliary contacts of overload relay	1
Number of NO contacts of auxiliary contacts of overload relay	1
Operating current of auxiliary contacts of overload relay	
<ul style="list-style-type: none"> • at AC at 600 V 	5 A
<ul style="list-style-type: none"> • at DC at 250 V 	1 A
Contact rating of auxiliary contacts of overload relay according to UL	5A@600VAC (B600), 1A@250VDC (R300)
Insulation voltage	
<ul style="list-style-type: none"> • with single-phase operation at AC rated value 	600 V
<ul style="list-style-type: none"> • with multi-phase operation at AC rated value 	300 V

Enclosure

Degree of protection NEMA rating of the enclosure	NEMA 4X fiberglass enclosure
Design of the housing	Dust-tight, watertight & corrosion resistant

Mounting/wiring

Mounting position	Vertical
Mounting type	Surface mounting and installation
Type of electrical connection for supply voltage line-side	Box lug
Tightening torque [lbf-in] for supply	45 ... 45 lbf-in
Type of connectable conductor cross-sections at line-side at AWG conductors single or multi-stranded	1x (14 ... 2 AWG)
Temperature of the conductor for supply maximum permissible	75 °C
Material of the conductor for supply	AL or CU
Type of electrical connection for load-side outgoing feeder	Box lug
Tightening torque [lbf-in] for load-side outgoing feeder	45 ... 45 lbf-in
Type of connectable conductor cross-sections at AWG conductors for load-side outgoing feeder single or multi-stranded	1x (14 ... 2 AWG)
Temperature of the conductor for load-side outgoing feeder maximum permissible	75 °C
Material of the conductor for load-side outgoing feeder	AL or CU

Type of electrical connection of magnet coil	Screw-type terminals
Tightening torque [lbf·in] at magnet coil	5 ... 12 lbf·in
Type of connectable conductor cross-sections of magnet coil at AWG conductors single or multi-stranded	2x (16 ... 12 AWG)
Temperature of the conductor at magnet coil maximum permissible	75 °C
Material of the conductor at magnet coil	CU
Type of electrical connection for auxiliary contacts	Screw-type terminals
Tightening torque [lbf·in] at contactor for auxiliary contacts	10 ... 15 lbf·in
Type of connectable conductor cross-sections at contactor at AWG conductors for auxiliary contacts single or multi-stranded	1x (12 AWG), 2x (16 ... 14 AWG), 2x (18 ... 16 AWG)
Temperature of the conductor at contactor for auxiliary contacts maximum permissible	75 °C
Material of the conductor at contactor for auxiliary contacts	CU
Type of electrical connection at overload relay for auxiliary contacts	Screw-type terminals
Tightening torque [lbf·in] at overload relay for auxiliary contacts	7 ... 10 lbf·in
Type of connectable conductor cross-sections at overload relay at AWG conductors for auxiliary contacts single or multi-stranded	2x (20 ... 14 AWG)
Temperature of the conductor at overload relay for auxiliary contacts maximum permissible	75 °C
Material of the conductor at overload relay for auxiliary contacts	CU

Short-circuit current rating

Design of the fuse link for short-circuit protection of the main circuit required	10kA@600V (Class H or K); 100kA@600V (Class R or J)
Design of the short-circuit trip	Thermal magnetic circuit breaker
Maximum short-circuit current breaking capacity (Icu) <ul style="list-style-type: none"> • at 240 V • at 480 V • at 600 V 	14 kA 10 kA 10 kA

Further information

Industrial Controls - Product Overview (Catalogs, Brochures,...)

www.usa.siemens.com/iccatalog

Industry Mall (Online ordering system)

<https://mall.industry.siemens.com/mall/en/us/Catalog/product?mlfb=US2:30FUFF32F2VC>

Service&Support (Manuals, Certificates, Characteristics, FAQs,...)

<https://support.industry.siemens.com/cs/US/en/ps/US2:30FUFF32F2VC>

Image database (product images, 2D dimension drawings, 3D models, device circuit diagrams, EPLAN macros, ...)

http://www.automation.siemens.com/bilddb/cax_de.aspx?mlfb=US2:30FUFF32F2VC&lang=en

Certificates/approvals

<https://support.industry.siemens.com/cs/US/en/ps/US2:30FUFF32F2VC/certificate>

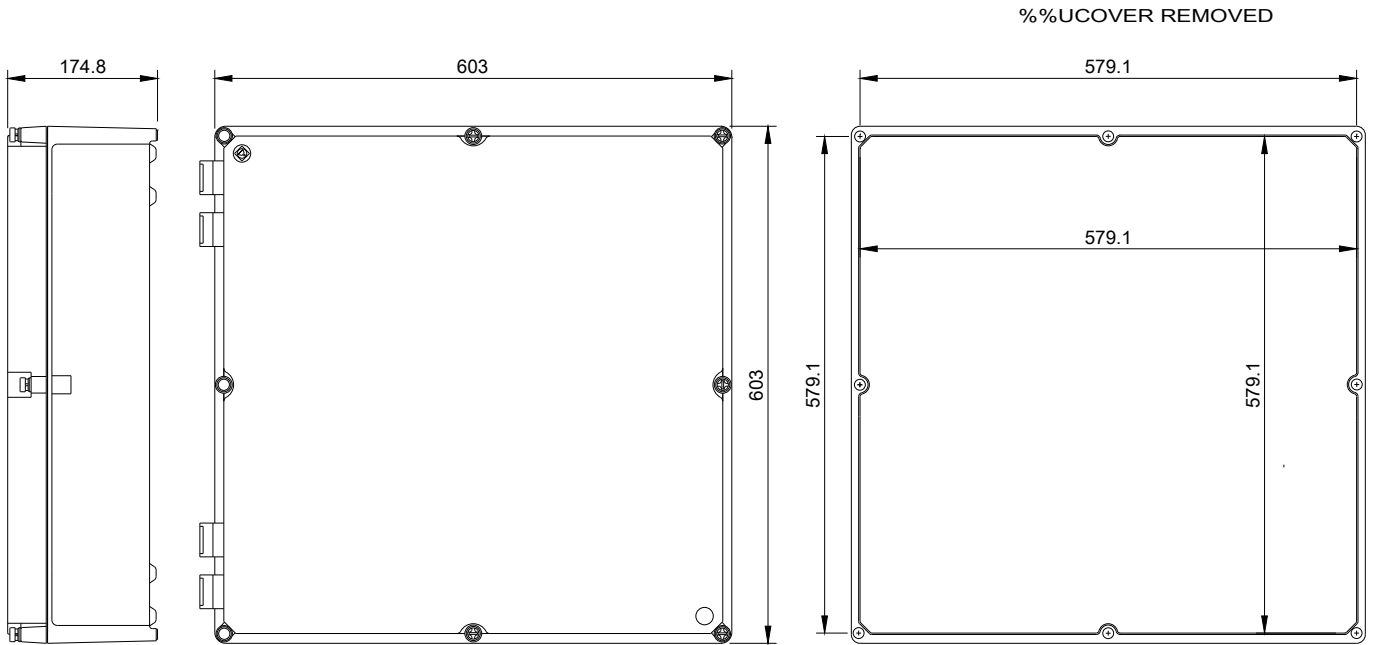

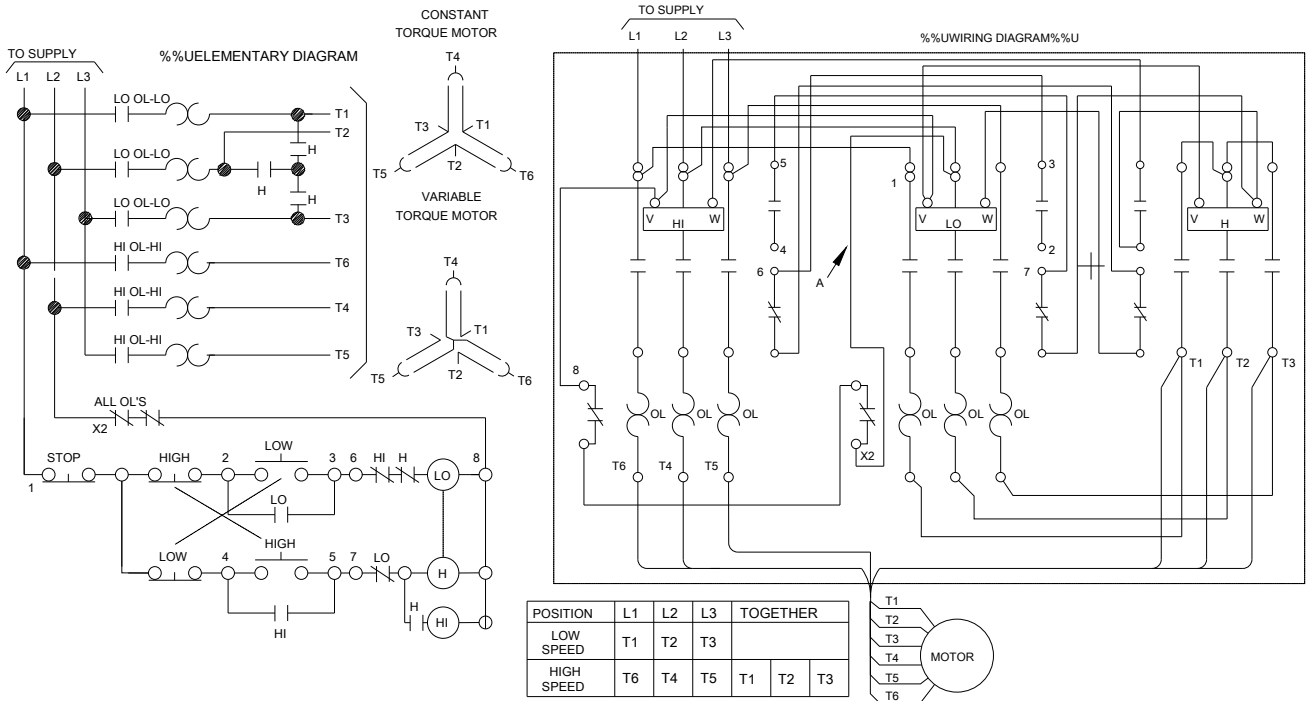

D26434001

last modified:

05/13/2019