

Pump control panel Size 3 Three phase full voltage Amb compensate bimetal OLrelay Contactor amp rating 90 AMP 24VAC 50-60HZ coil Standard type contactor 100A fusible disconnect 100A/250V fuse clip HOA Sel. SW & Start/Stop PB Enclosure NEMA type 3/3R Weather proof outdoor use



Figure similar

General technical data	
Weight [lb]	81 lb
Height x Width x Depth [in]	41 × 24 × 8 in
Protection against electrical shock	NA for enclosed products
Installation altitude [ft] at height above sea level maximum	6560 ft
Ambient temperature [°F] during storage	-22 ... +149 °F
Ambient temperature [°F] during operation	-4 ... +104 °F
Ambient temperature during storage	-30 ... +65 °C
Ambient temperature during operation	-20 ... +40 °C
Country of origin	USA

Horsepower ratings	
Yielded mechanical performance [hp] for three-phase AC motor	
<ul style="list-style-type: none"> at 200/208 V rated value 	25 hp
<ul style="list-style-type: none"> at 220/230 V rated value 	30 hp
<ul style="list-style-type: none"> at 460/480 V rated value 	0 hp

- at 575/600 V rated value

0 hp

Contactors

Number of NO contacts for main contacts	3
Operating voltage for main current circuit at AC at 60 Hz maximum	600 V
Operating current at AC at 600 V rated value	90 A
Mechanical service life (switching cycles) of the main contacts typical	5000000

Auxiliary contact

Number of NC contacts at contactor for auxiliary contacts	0
Number of NO contacts at contactor for auxiliary contacts	1
Number of total auxiliary contacts maximum	7
Contact rating of auxiliary contacts of contactor according to UL	10A@600VAC (A600), 5A@600VDC (P600)

Coil

Type of voltage of the control supply voltage	AC
Control supply voltage	
<ul style="list-style-type: none"> • at DC rated value 	0 ... 0 V
<ul style="list-style-type: none"> • at AC at 60 Hz rated value 	24 ... 24 V
<ul style="list-style-type: none"> • at AC at 50 Hz rated value 	24 ... 24 V
Holding power at AC minimum	14 W
Apparent pick-up power of magnet coil at AC	310 V·A
Apparent holding power of magnet coil at AC	26 V·A
Operating range factor control supply voltage rated value of magnet coil	0.85 ... 1.1
Percental drop-out voltage of magnet coil related to the input voltage	50 %
Switch-on delay time	26 ... 41 ms
Off-delay time	14 ... 19 ms

Overload relay

Product function	
<ul style="list-style-type: none"> • Overload protection 	Yes
<ul style="list-style-type: none"> • Test function 	Yes
<ul style="list-style-type: none"> • External reset 	Yes
Reset function	Manual and automatic
Adjustment range of thermal overload trip unit	0.85 ... 1.15
Number of NC contacts of auxiliary contacts of overload relay	3
Number of NO contacts of auxiliary contacts of overload relay	0

Operating current of auxiliary contacts of overload relay	
<ul style="list-style-type: none"> • at AC at 600 V • at DC at 250 V 	<p>5 A</p> <p>5 A</p>
Contact rating of auxiliary contacts of overload relay according to UL	5A@600VAC (B600), 5A@250VDC (P300)

Disconnect Switch

Rated response values of switch disconnecter	100A / 600V
Design of fuse holder	Class H fuse clips
Operating class of the fuse link	Class H, J (convertible), K and R

Enclosure

Degree of protection NEMA rating of the enclosure	NEMA 3/3R
Design of the housing	Weather proof for outdoor use

Standard Control Devices

Product component Hand-Off-Auto selector switch	Yes
Type of Hand-Off-Auto selector switch	30mm metal housing with chrome finish
Product component Start push button	Yes
Type of start push button	30mm metal housing with chrome finish

Mounting/wiring

(mounting position)	Vertical
(mounting type)	Surface mounting and installation
Type of electrical connection for supply voltage line-side	Box lug
Tightening torque [lbf·in] for supply	120 ... 120 lbf·in
Type of connectable conductor cross-sections at line-side at AWG conductors single or multi-stranded	1x (14 ... 1/0 AWG)
Temperature of the conductor for supply maximum permissible	75 °C
Material of the conductor for supply	AL or CU
Type of electrical connection for load-side outgoing feeder	Screw-type terminals
Tightening torque [lbf·in] for load-side outgoing feeder	35 ... 50 lbf·in
Type of electrical connection of magnet coil	Screw-type terminals
Tightening torque [lbf·in] at magnet coil	5 ... 12 lbf·in
Type of connectable conductor cross-sections of magnet coil at AWG conductors single or multi-stranded	2x (16 ... 12 AWG)
Temperature of the conductor at magnet coil maximum permissible	75 °C
Material of the conductor at magnet coil	CU
Type of electrical connection at contactor for auxiliary contacts	Screw-type terminals

Tightening torque [lbf-in] at contactor for auxiliary contacts	10 ... 15 lbf-in
Type of connectable conductor cross-sections at contactor at AWG conductors for auxiliary contacts single or multi-stranded	1x (12 AWG), 2x (16 ... 14 AWG), 2x (18 ... 16 AWG)
Temperature of the conductor at contactor for auxiliary contacts maximum permissible	75 °C
Material of the conductor at contactor for auxiliary contacts	CU
Type of electrical connection at overload relay for auxiliary contacts	Screw-type terminals
Tightening torque [lbf-in] at overload relay for auxiliary contacts	5 ... 12 lbf-in
Type of connectable conductor cross-sections at overload relay at AWG conductors for auxiliary contacts single or multi-stranded	2x (16 ... 12 AWG)
Temperature of the conductor at overload relay for auxiliary contacts maximum permissible	75 °C
Material of the conductor at overload relay for auxiliary contacts	CU

Short-circuit current rating

Design of the fuse link for short-circuit protection of the main circuit required	10kA@600V (Class H or K); 100kA@600V (Class R or J)
---	---

Further information

Industrial Controls - Product Overview (Catalogs, Brochures,...)

www.usa.siemens.com/iccatalog

Industry Mall (Online ordering system)

<https://mall.industry.siemens.com/mall/en/us/Catalog/product?mlfb=US2:87HAN6LJ>

Service&Support (Manuals, Certificates, Characteristics, FAQs,...)

<https://support.industry.siemens.com/cs/US/en/ps/US2:87HAN6LJ>

Image database (product images, 2D dimension drawings, 3D models, device circuit diagrams, EPLAN macros, ...)

http://www.automation.siemens.com/bilddb/cax_de.aspx?mlfb=US2:87HAN6LJ&lang=en

Certificates/approvals

<https://support.industry.siemens.com/cs/US/en/ps/US2:87HAN6LJ/certificate>

LETTER	CONDUIT SIZE
A	%%C22.2 & %%C28.6 CONDUIT
B	Ø50 & Ø62.7 CONDUIT

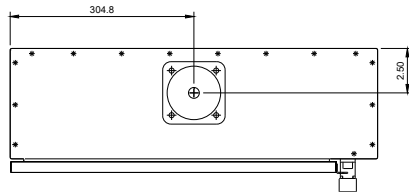
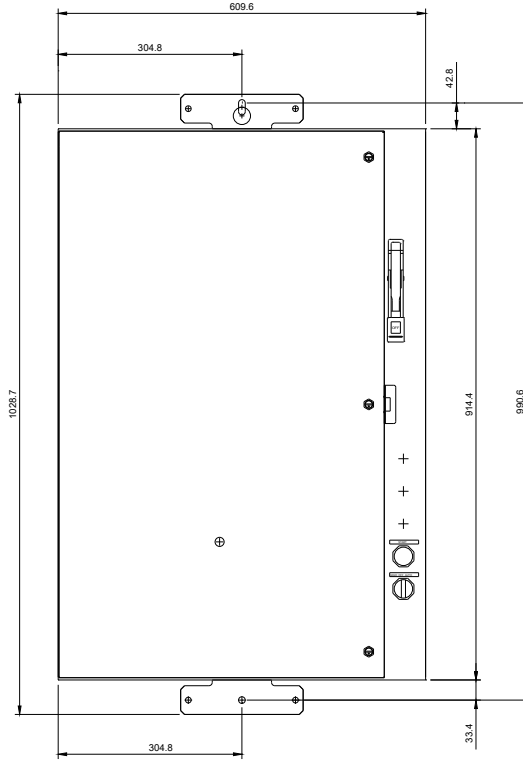
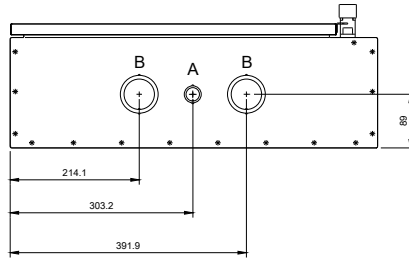
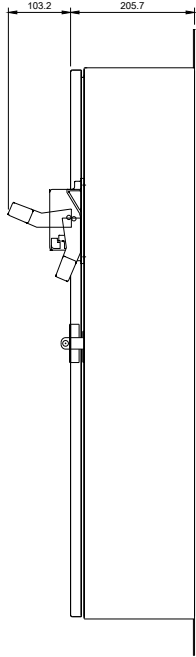

CONDUIT HUB COVER

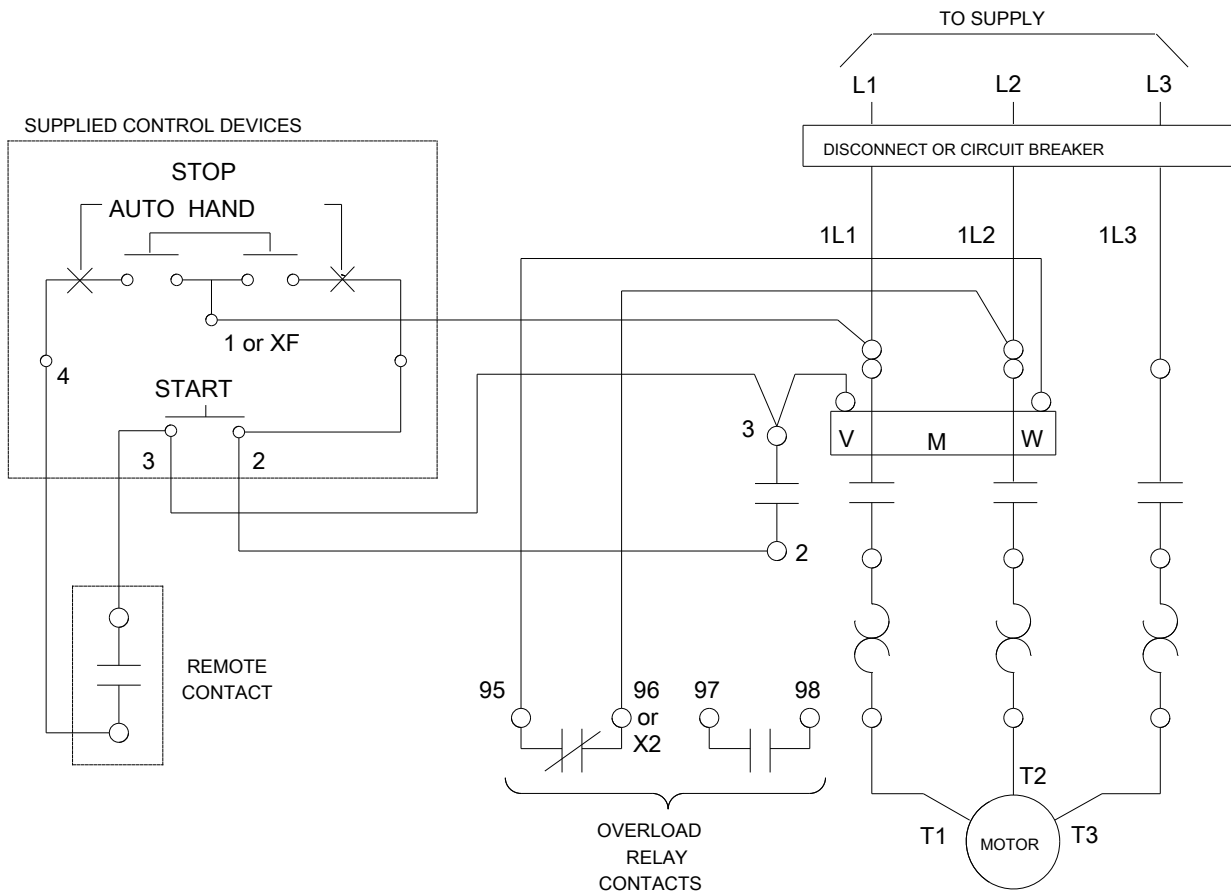

D63677012

last modified:

05/08/2019