

Mechanically held lighting contactor, Contactor amp rating 100A, 3 normally open poles, 24VAC 60HZ Coil, Combination type, 100A/600V non-fuse disconnect, Enclosure NEMA type 1, Indoor general purpose use



Figure similar

General technical data	
Weight [lb]	82 lb
Height x Width x Depth [in]	24 × 20 × 8 in
Protection against electrical shock	NA for enclosed products
Installation altitude [ft] at height above sea level maximum	6560 ft
Country of origin	USA
Contactor	
Number of NO contacts for main contacts	3
Number of NC contacts for main contacts	0
Operating voltage for main current circuit at AC at 60 Hz maximum	600 V
Mechanical service life (switching cycles) of the main contacts typical	5000000
Contact rating of the main contacts of lighting contactor	
<ul style="list-style-type: none"> <li>• at tungsten (1 pole per 1 phase) rated value</li> <li>• at tungsten (2 poles per 1 phase) rated value</li> </ul>	100A @277V 1p 1ph 100A @480V 2p 1ph

- at tungsten (3 poles per 3 phases) rated value
- at ballast (1 pole per 1 phase) rated value
- at ballast (2 poles per 1 phase) rated value
- at ballast (3 poles per 3 phases) rated value
- at resistive load (1 pole per 1 phase) rated value
- at resistive load (2 poles per 1 phase) rated value
- at resistive load (3 poles per 3 phases) rated value

100A @480V 3p 3ph  
 100A @347V 1p 1ph  
 100A @600V 2p 1ph  
 100A @600V 3p 3ph  
 100A @347V 1p 1ph  
 100A @600V 2p 1ph  
 100A @600V 3p 3ph

#### Auxiliary contact

Number of NC contacts for auxiliary contacts	0
Number of NO contacts for auxiliary contacts	0
Number of total auxiliary contacts maximum	4
Contact rating of auxiliary contacts of contactor according to UL	NA

#### Coil

Type of voltage of the control supply voltage	AC
Control supply voltage	
<ul style="list-style-type: none"> <li>• at DC rated value</li> <li>• at AC at 60 Hz rated value</li> <li>• at AC at 50 Hz rated value</li> </ul>	0 ... 0 V 24 ... 24 V 0 ... 0 V
Apparent pick-up power of magnet coil at AC	900 V·A
Apparent holding power of magnet coil at AC	200 V·A
Operating range factor control supply voltage rated value of magnet coil	0.85 ... 1.1

#### Disconnect Switch

Rated response values of switch disconnecter	100A / 600V
Design of fuse holder	non-fusible
Operating class of the fuse link	non-fusible

#### Enclosure

Degree of protection NEMA rating of the enclosure	NEMA 1 enclosure
Design of the housing	Indoor general purpose use

#### Mounting/wiring

(mounting position)	Vertical
(mounting type)	Surface mounting and installation
Type of electrical connection for supply voltage line-side	Box lug
Tightening torque [lbf·in] for supply	120 ... 120 lbf·in
Type of connectable conductor cross-sections at line-side at AWG conductors single or multi-stranded	1x (14 ... 1/0 AWG)

Temperature of the conductor for supply maximum permissible	75 °C
Material of the conductor for supply	AL or CU
Type of electrical connection for load-side outgoing feeder	Box lug
Tightening torque [lbf·in] for load-side outgoing feeder	90 ... 100 lbf·in
Type of connectable conductor cross-sections at AWG conductors for load-side outgoing feeder single or multi-stranded	1x (6 ... 1/0 AWG)
Temperature of the conductor for load-side outgoing feeder maximum permissible	75 °C
Material of the conductor for load-side outgoing feeder	AL or CU
Type of electrical connection of magnet coil	Screw-type terminals
Tightening torque [lbf·in] at magnet coil	8 ... 12 lbf·in
Type of connectable conductor cross-sections of magnet coil at AWG conductors single or multi-stranded	2x (16 ... 12 AWG)
Temperature of the conductor at magnet coil maximum permissible	75 °C
Material of the conductor at magnet coil	CU

#### Short-circuit current rating

Design of the fuse link for short-circuit protection of the main circuit required	5kA@600V
---	----------

#### Further information

##### Industrial Controls - Product Overview (Catalogs, Brochures,...)

[www.usa.siemens.com/iccatalog](http://www.usa.siemens.com/iccatalog)

##### Industry Mall (Online ordering system)

<https://mall.industry.siemens.com/mall/en/us/Catalog/product?mlfb=US2:CMNE16024>

##### Service&Support (Manuals, Certificates, Characteristics, FAQs,...)

<https://support.industry.siemens.com/cs/US/en/ps/US2:CMNE16024>

##### Image database (product images, 2D dimension drawings, 3D models, device circuit diagrams, EPLAN macros, ...)

[http://www.automation.siemens.com/bilddb/cax\\_de.aspx?mlfb=US2:CMNE16024&lang=en](http://www.automation.siemens.com/bilddb/cax_de.aspx?mlfb=US2:CMNE16024&lang=en)

##### Certificates/approvals

<https://support.industry.siemens.com/cs/US/en/ps/US2:CMNE16024/certificate>

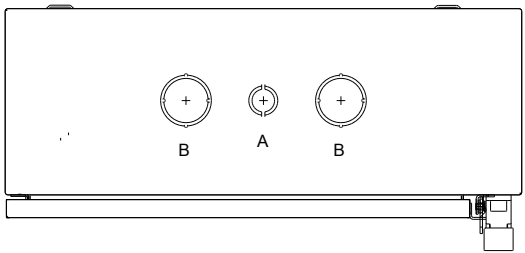
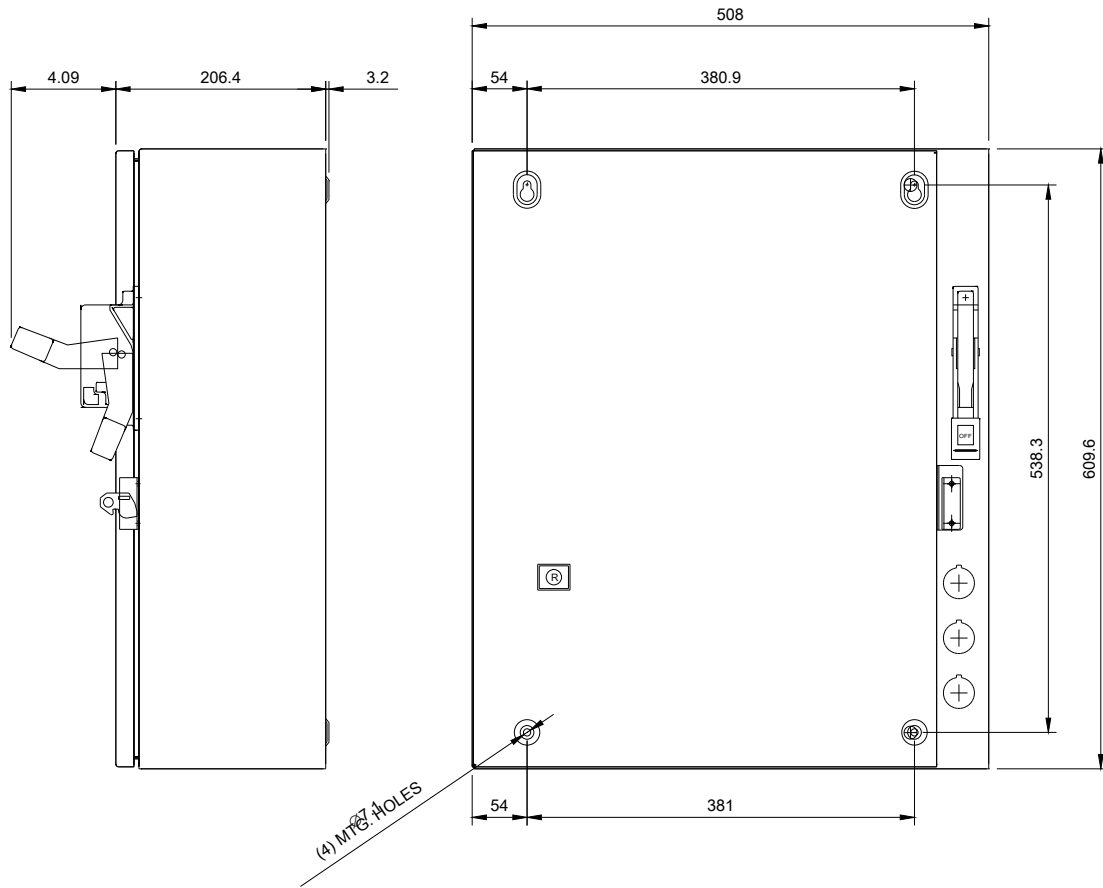

ΛCONDUITS TYP. TOP & BOTTOM

LETTER	CONDUIT SIZE
A	%%C12.7 & %%C19 CONDUIT
B	∅31.8 & ∅38.1 CONDUIT

Wiring Diagram Class CLM  
Combination Type  
30-300 Amp 3 Pole

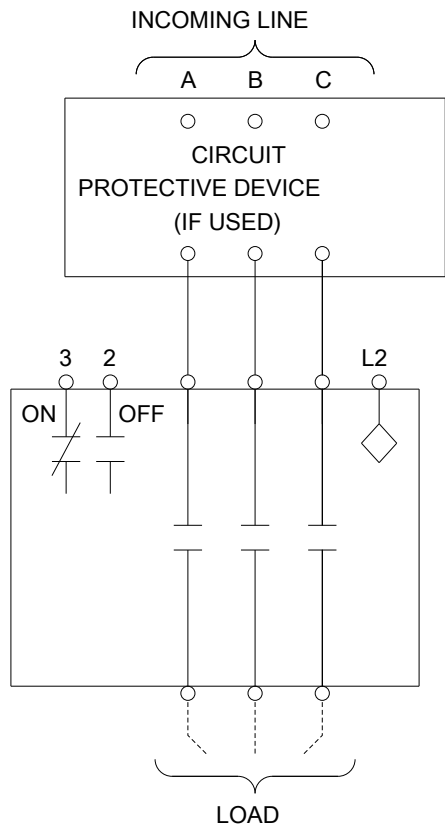

E87010-A0412-T009-A1-CLM

last modified:

05/08/2019