

Series 14 Two Door Consoles

Application -

Designed for electronic controls and instruments. Equipment can be mounted on the sloping control panel door. Interior components mount to stationary panels. Heavy duty construction provides protection from dirt, oil, dust, and water. For installation information, consult our Installation Manual at www.saginawcontrol.com.

Construction -

- 0.104" carbon steel.
- Sloping control panel door attached with concealed hinge on bottom edge. Door opens to 90°.
- Black zinc die cast keylocking/padlocking handles on front and rear doors.
- 3-point latching mechanism.
- Seams continuously welded and ground smooth.
- Oil-resistant gasket on door.
- Optional equipment mounts to horizontal channels welded to sides.
- Flush mounted doors.
- Optional writing desk and top section available.
- Interior print pocket.
- Removable eyebolts in console body.
- Ground stud on door.

Finish -

ANSI-61 gray powder coated inside and out. Optional panels are powder coated white.

IS1 - Industry Standards -

NEMA Type 12 & Type 13

UL Listed Type 12

CSA Type 12

IEC 60529 IP 55



SERIES 14 TWO DOOR CONSOLES - 48" WIDE

ENCLOSURES							
Catalog No.	Description	Height (A)	Width (B)	Depth (C)	Product Code	Industry Standard	List Price
SCE-1448BD	Console Body	50.00	48.00	23.00	C1	IS1	2,673.68
SCE-1448T	Console Top	16.00	48.00	12.50	C1	IS1	670.95
SCE-1448P2	Half Panel	22.00	41.00		P3	IS1	212.67
SCE-1448P3	Full Panel	42.25	41.00		P3	IS1	336.74
SCE-1448W	Writing Desk	48.00	10.00		P2	IS1	214.61

SERIES 14 TWO DOOR CONSOLES - 60" WIDE

ENCLOSURES							
Catalog No.	Description	Height (A)	Width (B)	Depth (C)	Product Code	Industry Standard	List Price
SCE-1460BD	Console Body	50.00	60.00	23.00	C1	IS1	2,767.36
SCE-1460T	Console Top	16.00	60.00	12.50	C1	IS1	777.29
SCE-1460P2	Half Panel	22.00	53.00		P3	IS1	245.59
SCE-1460P3	Full Panel	42.25	53.00		P3	IS1	402.57
SCE-1460W	Writing Desk	60.00	10.00		C2	IS1	253.19

SERIES 14 TWO DOOR CONSOLES - 72" WIDE

ENCLOSURES							
Catalog No.	Description	Height (A)	Width (B)	Depth (C)	Product Code	Industry Standard	List Price
SCE-1472BD	Console Body	50.00	72.00	23.00	C1	IS1	3,030.68
SCE-1472T	Console Top	16.00	72.00	12.50	C1	IS1	886.17
SCE-1472P3	Full Panel	42.25	65.00		P3	IS1	465.86
SCE-1472W	Writing Desk	72.00	10.00		P2	IS1	291.78

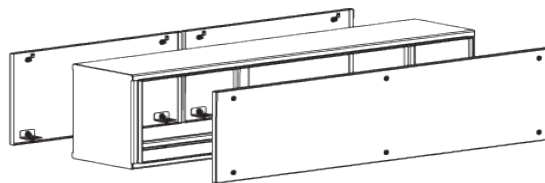

OPTIONAL TOP NOTES:
1. SINGLE FRONT & TWO REAR ACCESS PANELS ON 48.00 [1219] & 60.00 [1524] WIDE.
2. TWO FRONT & TWO REAR ACCESS PANELS ON 72.00 [1829] WIDE.

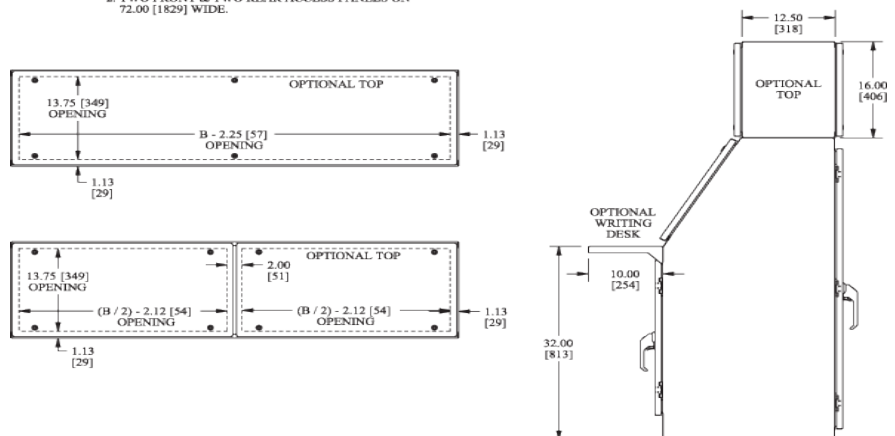

Phone (989) 799-6871

Fax (989) 799-4524



SERIES 14 TWO DOOR CONSOLES

TECHNICAL DATA

