

## Fiberglass Junction Enclosures With Window

### Application -

Designed for indoor or outdoor use to house electronic controls, instruments and components in areas that may be regularly hosed down, are in very wet conditions, or are exposed to corrosive agents and require unrestricted viewing of gauges or controls. Provides protection from dust, dirt, oil and water.

### Construction -

- Fiberglass reinforced compression molded polyester.
- Continuous memory retaining gasket.
- Mounting strips molded in.
- Quick release padlock latch.
- Integral panel mounting inserts.
- Stainless steel continuous hinge.
- UVA acrylic bonded window

### Finish -

Light gray fiberglass. Optional sub-panels are marine grade aluminum.

### IS5 - Industry Standards -

NEMA Type 4, 4X, 12 & Type 13  
UL Listed Type 4, 4X & 12  
CSA Type 4, 4X & 12  
IEC 60529 IP66



## FIBERGLASS JUNCTION ENCLOSURES WITH WINDOW

ENCLOSURE PRODUCT CODE F1									
Catalog No.	Height (A)	Width (B)	Depth (C)	Mounting (G)	Mounting (H)	Interior (J)	Interior (K)	Interior (L)	Industry Standard
SCE-604FW	7.39	5.43	4.75	6.75	2.00	5.84	3.85	4.00	IS5
SCE-606FW	7.52	7.50	4.75	6.75	4.00	5.72	5.72	4.00	IS5
SCE-808FW	9.50	9.41	4.75	8.88	4.00	7.73	5.74	4.00	IS5
SCE-806FW	9.50	7.50	4.75	8.75	6.00	7.73	7.73	4.06	IS5
SCE-1008FW	11.35	9.41	4.25	10.75	6.00	9.73	7.73	3.50	IS5
SCE-10086FW	11.37	9.37	5.06	10.75	6.00	9.73	7.73	4.37	IS5
SCE-1210FW	13.41	11.43	5.21	12.75	8.00	11.79	9.80	4.50	IS5
SCE-1212FW	13.41	13.50	5.21	12.75	10.00	11.70	11.70	5.53	IS5
SCE-1407FW	15.75	8.75	6.81	15.00	5.00	14.00	7.00	6.12	IS5
SCE-1412FW	15.47	13.50	6.25	14.62	10.00	13.53	11.55	5.37	IS5
SCE-1614FW	17.45	15.46	6.23	16.75	12.00	15.63	13.60	5.36	IS5
SCE-1816FW	19.61	17.61	8.82	18.88	12.00	17.69	15.69	7.99	IS5
SCE-2016FW	21.68	17.68	8.83	21.25	10.00	19.72	15.72	8.00	IS5

SUB-PANELS (F2)		
Catalog No.	Panel Height (D)	Panel Width (E)
SCE-6P4AL	4.88	2.88
SCE-6P6AL	4.88	4.88
SCE-8P6AL	6.88	4.88
SCE-8P8AL	6.75	6.88
SCE-10P8AL	8.88	6.88
SCE-12P10AL	10.88	8.88
SCE-12P12AL	10.88	10.88
SCE-14P8AL	12.88	5.88
SCE-14P12AL	12.88	10.88
SCE-16P14AL	14.88	12.88
SCE-18P16AL	16.88	14.88
SCE-20PJ16AL	18.88	14.88

Phone (989) 799-6871  
Fax (989) 799-4524

**SCE** SAGINAW  
CONTROL &  
ENGINEERING  
Your Enclosure Source™

# FIBERGLASS JUNCTION ENCLOSURES WITH WINDOW

## TECHNICAL DATA

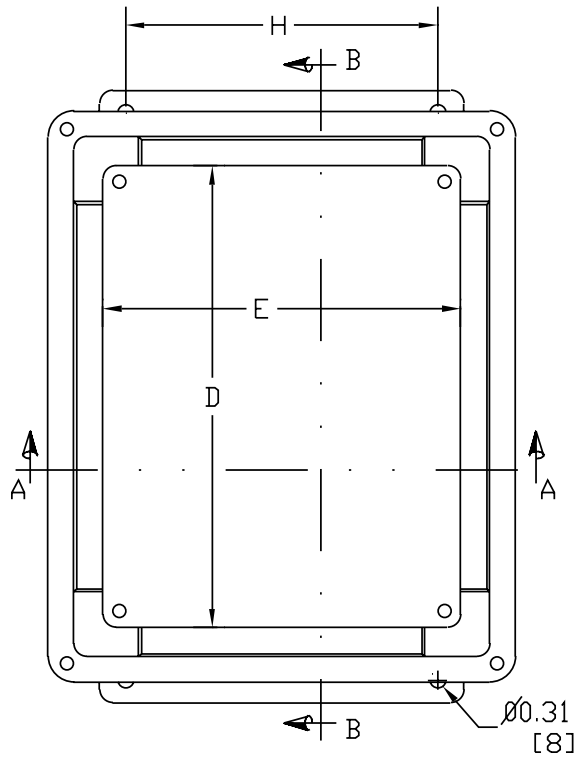

FRONT VIEW WITH COVER REMOVED

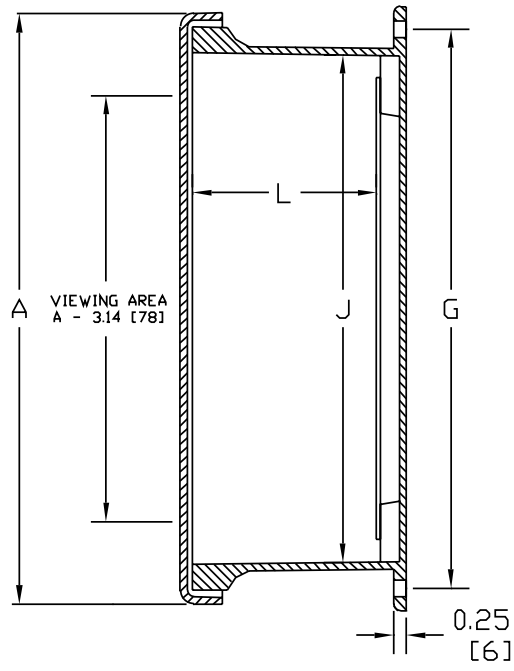

SECTION B-B

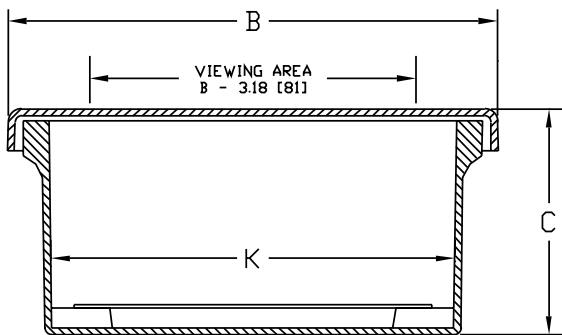

SECTION A-A