

# KBPC-240D

PENTA-DRIVE™

NEMA-4X, IP-65

Variable Speed-Torque SCR DC Motor Control  
for Shunt Wound and PM Motors

## ONE MODEL COVERS:

1/50 – 1 Hp @ 115 VAC – 50/60 Hz

1/25 – 2 Hp @ 230 VAC – 50/60 Hz

Washdown and Watertight  
for Indoor and Outdoor Use



## STANDARD FEATURES

- Electronic Overload Protection
  - Built-in Armature Fusing<sup>▲</sup>
  - LED's for "Power On," "Overload" and "Stop"
  - Electronic Start-Stop
- <sup>▲</sup> Fuse supplied separately

## JUMPER SELECTABLE FEATURES

- Control Mode: **Speed**, Torque
- DC Current Output (ADC): 2.5, 5.0, 7.5, **10**
- AC Line Voltage (VAC-50/60 Hz): 115, **230**
- DC Armature Voltage (VDC): 90, **180**
- Feedback Type: **Armature**, Tachometer
- Tachometer Voltage<sup>▲</sup> (VDC): **7**, 20/30, 50
- Timed Current Limit: **TCL**, NTCL

Bold figure indicates factory setting. <sup>▲</sup> Per 1,000 RPM

## TRIMPOT ADJUSTMENTS

- Minimum Speed (MIN)
- Maximum Speed (MAX)
- Current Limit (CL)
- IR Compensation (IR)
- Acceleration (ACCEL)
- Deceleration (DECEL)
- Timed Current Limit (TCL)
- Jog Speed (JOG)<sup>▲</sup>

<sup>▲</sup> Used with Run-Stop-Jog option.

## OPTIONAL FEATURES

- Forward-Brake-Reverse Switch with hesitation feature (P/N 9339). Includes switch and prewired dynamic brake resistor.
- Run-Stop-Jog Switch (P/N 9340)
- Signal Isolator, KBSI-240D (P/N 9431)
- On/Off AC Line Switch (P/N 9341)
- White Case (FDA) (P/N 9342)
- Electronic Pot, KBEP-240D (P/N 9108)
- Anti Plug Reversing Module (P/N 9378)
- Auto/Manual Kit (P/N 9377)

\* CE Compliance Requires KBRF-200A RFI Filter

## DESCRIPTION

The KBPC Series NEMA-4X (IP-65) SCR DC Motor Speed and Torque Control is designed for applications requiring washdown watertight integrity. Its housing is ruggedly constructed of die cast aluminum which is protected with an acrylic coating for the ultimate in corrosion resistance. All switches are sealed with rubber boots and the main speed potentiometer contains a shaft seal.

The KBPC state-of-the-art electronics include short circuit and transient protection to provide the ultimate in reliability. Electronics overload protection is also provided which prevents motor burnout and demagnetization of PM motors. The control can be operated in either the speed or torque mode via a jumper selection. The current range, which is also jumper selectable, eliminates the necessity for calibration of IR compensation and current limit for most applications. The KBPC also contains jumper selections for AC line voltage (230/115), DC armature voltage (180/90) and feedback type (armature/tachometer).

Standard features include Armature Fusing, Electronic Start/Stop and LED Indicator Array for "Power On," "Stop" and "Overload."

Although the KBPC is factory set for most applications, a variety of trimpots allows adjustment of the following parameters: MIN and MAX speed, Acceleration, Deceleration, Current Limit, IR Comp, and Timed Current Limit. The drive offers the ultimate in flexibility with the availability of several customer installed options. These include: Anti Plug Reversing Module, Forward-Brake-Reverse with Hesitation Feature, Run Stop-Jog, On/Off AC Line Switch, Input Signal Isolation, and Electronic Potentiometer. A complete instruction manual is included.

## SPECIFICATIONS

Parameter	Specification	Factory Setting
AC Line Voltage Regulation (% Base Speed)	±0.5	—
Current Ranges (ADC)	2.5, 5, 7.5, 10	10
ACCEL and DECEL Ranges (Seconds)	0.1–15	1
MIN SPEED Range (% Base Speed)	0–30	0
MAX SPEED Range (% Base Speed)	60–140	100
IR COMP Range at 115 VAC Line (VDC)	0–15	4
IR COMP Range at 230 VAC Line (VDC)	0–30	8
CL Range (% Range Setting)	0–200	150
TIMED CL Range (Seconds)	0.5–15	7
Voltage Following Linearity (% Base Speed)	± 0.5	—
AC Line Voltage (VAC ± 10%, 50/60 Hz)	115 or 230	230

Parameter	Specification	Factory Setting
Horsepower Range at 115 VAC Line (Hp) [kw]	1/50–1, [.015–.75]	—
Horsepower Range at 230 VAC Line (Hp) [kw]	1/25–2, [.03–1.5]	—
Armature Voltage Range at 115 VAC Line (VDC)	0–130*	—
Armature Voltage Range at 230 VAC Line (VDC)	0–220*	180
Field Voltage at 115 VAC Line (VDC)	100/50**	—
Field Voltage at 230 VAC Line (VDC)	200/100**	—
Ambient Temperature Range (°C)	0–50	—
Speed Range (Ratio)	50:1	—
Load Regulation, Arm. Feedback (% Base Speed)	± 1	—
Load Regulation, Tach. Feedback (% Set Speed)	± 1	—

**NOTES:** \*Maximum recommended output voltage is 90 VDC for 115 VAC and 180 VDC for 230 VAC. Exceeding these output voltages may cause a reduction in load regulation performance.

\*\*For shunt wound motor with lower voltage field, use L1 and F1 connection.

## ELECTRICAL RATINGS

Model Number	KB Part Number	AC Line Voltage (VAC) ± 10% 50/60 Hz	Motor Voltage (VDC)	Max. AC Load Current (RMS Amps)	Max. DC Load Current (DC Amps)	Maximum Horsepower Hp, (KW)	Field Voltage** (Volts DC)	
							Terminals F1, F2	Terminals F1, L1
KBPC-240D	9338 (Black)	115/230	0 – 130	15.0	10.2	1, (.75)	100	50
	9342 (White)		0 – 180	15.0	10.2	2, (1.5)	200	100
			0 – 130*					

\*Stepdown operation (90 VDC motors with 230 VAC input) can cause a reduction in motor performance. \*\*Shunt motors only

## MECHANICAL SPECIFICATIONS

INCHES  
[mm]

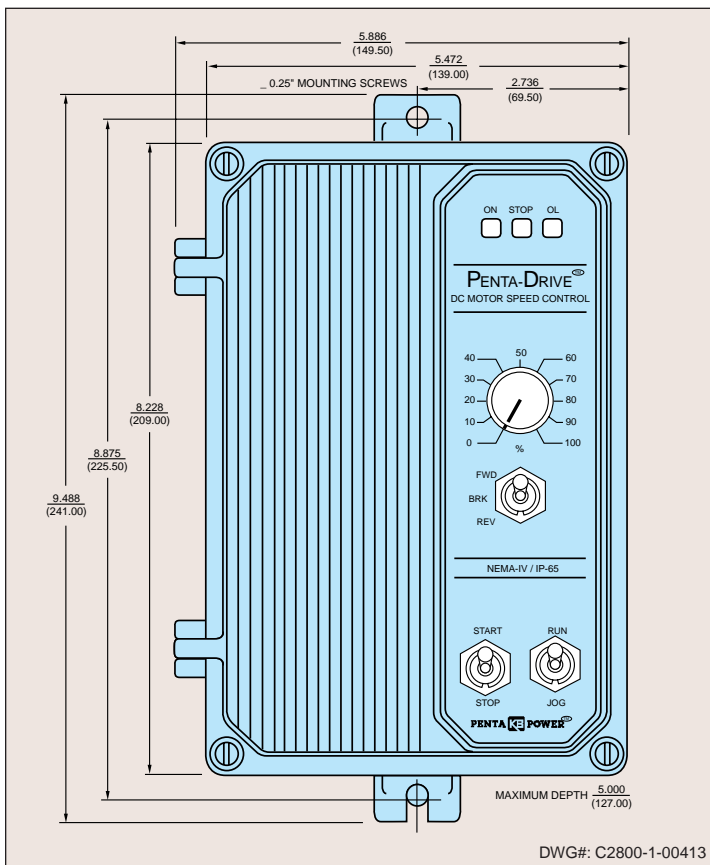

## CONNECTION DIAGRAM

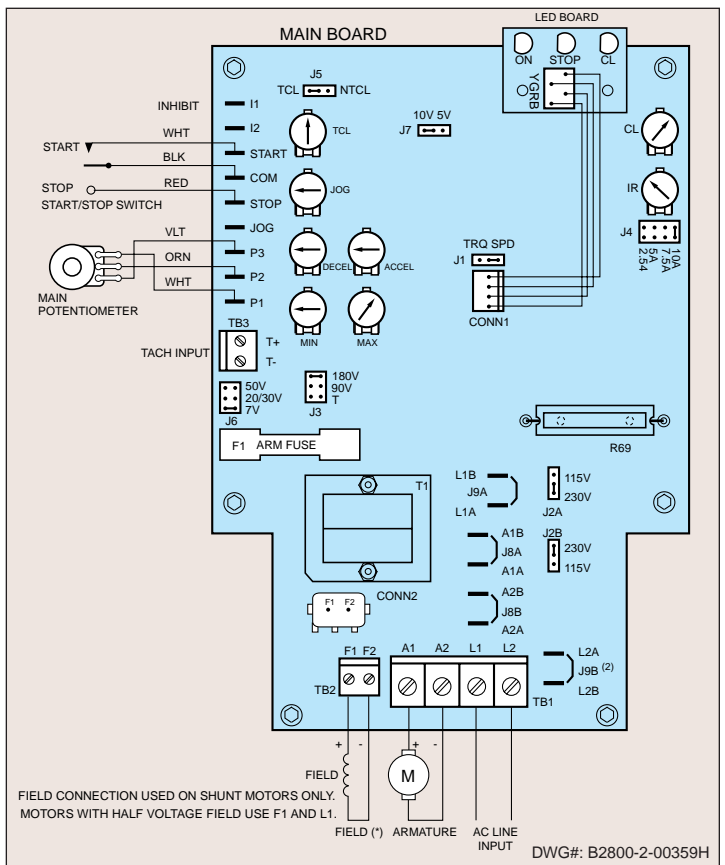

© 1998 KB Electronics, Inc.



**Distributed by ELECTRO SALES CO., INC.**  
 100 Fellsway West, Somerville MA 02145-2007  
 Phone: +1 (617) 666-0500 ~ Fax: +1 (617) 628-2800  
 Email: info@electrosales.com  
 www.electrosales.com/kb