

Duplex starter W/O alternator Size 1 Three phase full voltage Amb  
 compensate bimetal OLrelay Contactor amp rating 27Amp 24VAC  
 50-60HZ coil Non-combination type Enclosure NEMA type 12  
 Dust/drip proof for indoors



Figure similar

General technical data	
Weight [lb]	40 lb
Height x Width x Depth [in]	20 × 16 × 6 in
Protection against electrical shock	NA for enclosed products
Installation altitude [ft] at height above sea level maximum	6560 ft
Ambient temperature [°F] during storage	-22 ... +149 °F
Ambient temperature [°F] during operation	-4 ... +104 °F
Ambient temperature during storage	-30 ... +65 °C
Ambient temperature during operation	-20 ... +40 °C
Country of origin	USA

Horsepower ratings	
Yielded mechanical performance [hp] for three-phase AC motor	
<ul style="list-style-type: none"> <li>at 200/208 V rated value</li> </ul>	7.5 hp
<ul style="list-style-type: none"> <li>at 220/230 V rated value</li> </ul>	7.5 hp
<ul style="list-style-type: none"> <li>at 460/480 V rated value</li> </ul>	10 hp

- at 575/600 V rated value

10 hp

### Contactors

Number of NO contacts for main contacts	3
Operating voltage for main current circuit at AC at 60 Hz maximum	600 V
Operating current at AC at 600 V rated value	27 A
Mechanical service life (switching cycles) of the main contacts typical	10000000

### Auxiliary contact

Number of NC contacts at contactor for auxiliary contacts	0
Number of NO contacts at contactor for auxiliary contacts	1
Number of total auxiliary contacts maximum	8
Contact rating of auxiliary contacts of contactor according to UL	10A@600VAC (A600), 5A@600VDC (P600)

### Coil

Type of voltage of the control supply voltage	AC
Control supply voltage	
<ul style="list-style-type: none"> <li>• at DC rated value</li> </ul>	0 ... 0 V
<ul style="list-style-type: none"> <li>• at AC at 60 Hz rated value</li> </ul>	24 ... 24 V
<ul style="list-style-type: none"> <li>• at AC at 50 Hz rated value</li> </ul>	24 ... 24 V
Holding power at AC minimum	8.6 W
Apparent pick-up power of magnet coil at AC	218 V·A
Apparent holding power of magnet coil at AC	25 V·A
Operating range factor control supply voltage rated value of magnet coil	0.85 ... 1.1
Percental drop-out voltage of magnet coil related to the input voltage	50 %
Switch-on delay time	19 ... 29 ms
Off-delay time	10 ... 24 ms

### Overload relay

Product function	
<ul style="list-style-type: none"> <li>• Overload protection</li> </ul>	Yes
<ul style="list-style-type: none"> <li>• Test function</li> </ul>	Yes
<ul style="list-style-type: none"> <li>• External reset</li> </ul>	Yes
Reset function	Manual and automatic
Adjustment range of thermal overload trip unit	0.85 ... 1.15
Number of NC contacts of auxiliary contacts of overload relay	1
Number of NO contacts of auxiliary contacts of overload relay	0

Operating current of auxiliary contacts of overload relay	
<ul style="list-style-type: none"> <li>• at AC at 600 V</li> <li>• at DC at 250 V</li> </ul>	<p>10 A</p> <p>5 A</p>
Contact rating of auxiliary contacts of overload relay according to UL	10A@600VAC (A600), 5A@250VDC (P300)

### Enclosure

Degree of protection NEMA rating of the enclosure	NEMA 12 enclosure
Design of the housing	Dust tight and drip proof for indoors

### Mounting/wiring

(mounting position)	Vertical
(mounting type)	Surface mounting and installation
Type of electrical connection for supply voltage line-side	Screw-type terminals
Tightening torque [lbf-in] for supply	35 ... 35 lbf-in
Type of connectable conductor cross-sections at line-side at AWG conductors single or multi-stranded	1x (14 ... 2 AWG)
Temperature of the conductor for supply maximum permissible	75 °C
Material of the conductor for supply	AL or CU
Type of electrical connection for load-side outgoing feeder	Screw-type terminals
Tightening torque [lbf-in] for load-side outgoing feeder	35 ... 50 lbf-in
Type of electrical connection of magnet coil	Screw-type terminals
Tightening torque [lbf-in] at magnet coil	5 ... 12 lbf-in
Type of connectable conductor cross-sections of magnet coil at AWG conductors single or multi-stranded	2x (16 ... 12 AWG)
Temperature of the conductor at magnet coil maximum permissible	75 °C
Material of the conductor at magnet coil	CU
Type of electrical connection at contactor for auxiliary contacts	Screw-type terminals
Tightening torque [lbf-in] at contactor for auxiliary contacts	10 ... 15 lbf-in
Type of connectable conductor cross-sections at contactor at AWG conductors for auxiliary contacts single or multi-stranded	1x (12 AWG), 2x (16 ... 14 AWG), 2x (18 ... 16 AWG)
Temperature of the conductor at contactor for auxiliary contacts maximum permissible	75 °C
Material of the conductor at contactor for auxiliary contacts	CU
Type of electrical connection at overload relay for auxiliary contacts	Screw-type terminals

Tightening torque [lbf·in] at overload relay for auxiliary contacts	5 ... 12 lbf·in
Type of connectable conductor cross-sections at overload relay at AWG conductors for auxiliary contacts single or multi-stranded	2x (16 ... 12 AWG)
Temperature of the conductor at overload relay for auxiliary contacts maximum permissible	75 °C
Material of the conductor at overload relay for auxiliary contacts	CU

#### Short-circuit current rating

Design of the fuse link for short-circuit protection of the main circuit required	10kA@600V (Class H or K); 100kA@600V (Class R or J)
Design of the short-circuit trip	Thermal magnetic circuit breaker
Maximum short-circuit current breaking capacity (I <sub>cu</sub> )	
<ul style="list-style-type: none"> <li>• at 240 V</li> <li>• at 480 V</li> <li>• at 600 V</li> </ul>	14 kA 10 kA 10 kA

#### Further information

**Industrial Controls - Product Overview (Catalogs, Brochures,...)**

[www.usa.siemens.com/iccatalog](http://www.usa.siemens.com/iccatalog)

**Industry Mall (Online ordering system)**

<https://mall.industry.siemens.com/mall/en/us/Catalog/product?mlfb=US2:83DP950J81>

**Service&Support (Manuals, Certificates, Characteristics, FAQs,...)**

<https://support.industry.siemens.com/cs/US/en/ps/US2:83DP950J81>

**Image database (product images, 2D dimension drawings, 3D models, device circuit diagrams, EPLAN macros, ...)**

[http://www.automation.siemens.com/bilddb/cax\\_de.aspx?mlfb=US2:83DP950J81&lang=en](http://www.automation.siemens.com/bilddb/cax_de.aspx?mlfb=US2:83DP950J81&lang=en)

**Certificates/approvals**

<https://support.industry.siemens.com/cs/US/en/ps/US2:83DP950J81/certificate>

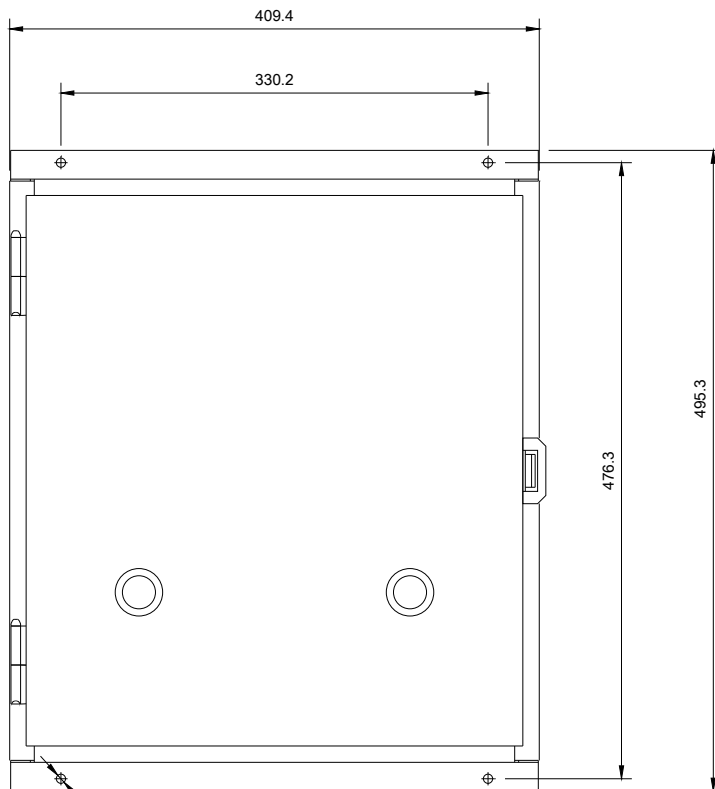
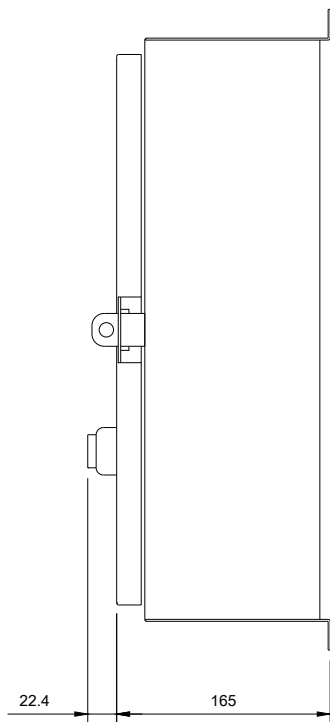

(\*) MFG RULES

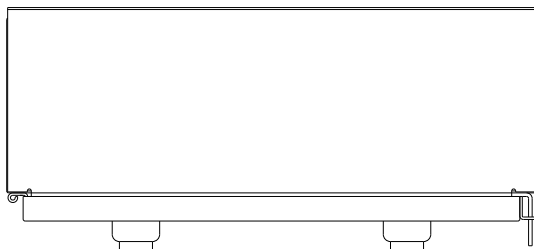

# %%USCHEMATIC DIAGRAM

Class 83 & 84 Duplex W/Manual Alternation Size 0-4

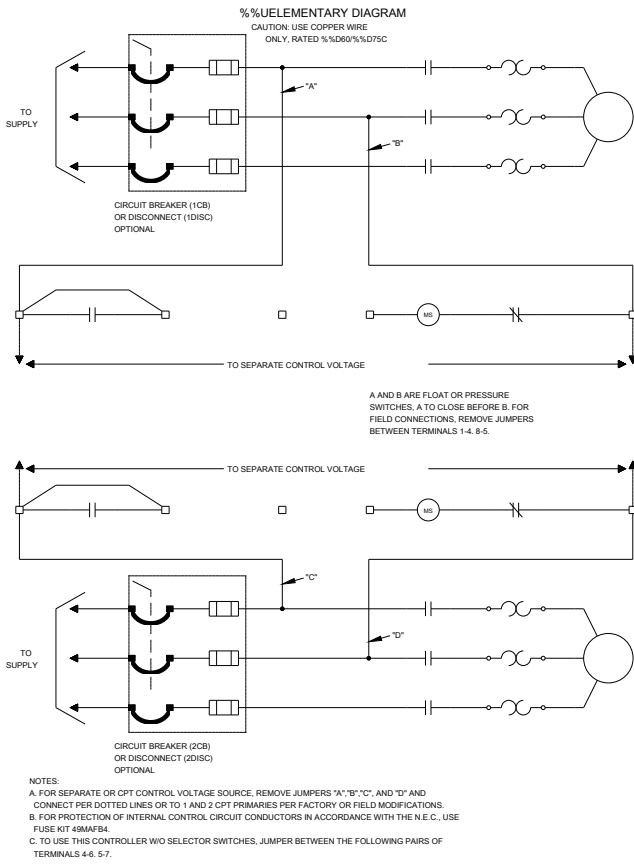

D68077003

last modified:

05/20/2019