

ACS800

Hardware Manual

ACS800-01 Drives (0.55 to 110 kW)

ACS800-U1 Drives (0.75 to 150 HP)



ABB

ACS800 Single Drive Manuals

HARDWARE MANUALS (appropriate manual is included in the delivery)

ACS800-01/U1 Hardware Manual 0.55 to 110 kW (0.75 to 150 HP)
3AFE64382101 (English)

ACS800-01/U1 Marine Supplement 3AFE 64291275 (English)

ACS800-02/U2 Hardware Manual 90 to 500 kW (125 to 600 HP)
3AFE64567373 (English)

ACS800-11/U11 Hardware Manual 5.5 to 110 kW (7.5 to 125 HP)
3AFE68367883 (English)

ACS800-31/U31 Hardware Manual 5.5 to 110 kW (7.5 to 125 HP)
3AFE68599954 (English)

ACS800-04 Hardware Manual 0.55 to 132 kW
3AFE68372984 (English)

ACS800-04/04M/U4 Hardware Manual 45 to 560 kW (60 to 600 HP)
3AFE64671006 (English)

ACS800-04/04M/U4 Cabinet Installation 45 to 560 kW (60 to 600 HP)
3AFE68360323 (English)

ACS800-07/U7 Hardware Manual 45 to 560 kW (50 to 600 HP)
3AFE64702165 (English)

ACS800-07/U7 Dimensional Drawings 45 to 560 kW (50 to 600 HP)
3AFE64775421

ACS800-07 Hardware Manual 500 to 2800 kW
3AFE64731165 (English)

ACS800-17 Hardware Manual 75 to 1120 kW
3AFE64681338 (English)

ACS800-37 Hardware Manual 160 to 2800 kW (200 to 2700 HP)
3AFE68557925 (English)

- Safety instructions
- Electrical installation planning
- Mechanical and electrical installation
- Motor control and I/O board (RMIO)
- Maintenance
- Technical data
- Dimensional drawings
- Resistor braking

FIRMWARE MANUALS, SUPPLEMENTS AND GUIDES

(appropriate documents are included in the delivery)

Standard Application Program Firmware Manual
3AFE64527592 (English)

System Application Program Firmware Manual
3AFE63700177 (English)

Application Program Template Firmware Manual
3AFE64616340 (English)

Master/Follower 3AFE64590430 (English)

PFC Application Program Firmware Manual
3AFE64649337 (English)

Extruder Control Program Supplement 3AFE64648543 (English)

Centrifuge Control Program Supplement 3AFE64667246 (English)

Traverse Control Program Supplement 3AFE64618334 (English)

Crane Control Program Firmware Manual 3BSE11179 (English)

Adaptive Programming Application Guide
3AFE64527274 (English)

OPTION MANUALS (delivered with optional equipment)

Fieldbus Adapters, I/O Extension Modules etc.

ACS800-01 Drives
0.55 to 110 kW
ACS800-U1 Drives
0.75 to 150 HP

Hardware Manual

3AFE64382101 Rev F EN
EFFECTIVE: 16.9.2005

Safety instructions

What this chapter contains

This chapter contains the safety instructions which you must follow when installing, operating and servicing the drive. If ignored, physical injury or death may follow, or damage may occur to the drive, motor or driven equipment. Read the safety instructions before you work on the unit.

To which products this chapter applies

This chapter applies to the ACS800-01/U1, ACS800-11/U11, ACS800-31/U31, ACS800-02/U2 and ACS800-04/04M/U4 of frame sizes R7 and R8.

Use of warnings and notes

There are two types of safety instructions throughout this manual: warnings and notes. Warnings caution you about conditions which can result in serious injury or death and/or damage to the equipment. They also tell you how to avoid the danger. Notes draw attention to a particular condition or fact, or give information on a subject. The warning symbols are used as follows:



Dangerous voltage warning warns of high voltage which can cause physical injury and/or damage to the equipment.



General warning warns about conditions, other than those caused by electricity, which can result in physical injury and/or damage to the equipment.



Electrostatic discharge warning warns of electrostatic discharge which can damage the equipment.

Installation and maintenance work

These warnings are intended for all who work on the drive, motor cable or motor.



WARNING! Ignoring the following instructions can cause physical injury or death, or damage to the equipment:

- **Only qualified electricians are allowed to install and maintain the drive.**
- Never work on the drive, motor cable or motor when main power is applied. After disconnecting the input power, always wait for 5 min to let the intermediate circuit capacitors discharge before you start working on the drive, motor or motor cable.

Always ensure by measuring with a multimeter (impedance at least 1 Mohm) that:

1. voltage between drive input phases U1, V1 and W1 and the frame is close to 0 V.
 2. voltage between terminals UDC+ and UDC- and the frame is close to 0 V.
- Do not work on the control cables when power is applied to the drive or to the external control circuits. Externally supplied control circuits may cause dangerous voltages inside the drive even when the main power on the drive is switched off.
 - Do not make any insulation or voltage withstand tests on the drive or drive modules.
 - When reconnecting the motor cable, always check that the phase order is correct.

Note:

- The motor cable terminals on the drive are at a dangerously high voltage when the input power is on, regardless of whether the motor is running or not.
- The brake control terminals (UDC+, UDC-, R+ and R- terminals) carry a dangerous DC voltage (over 500 V).
- Depending on the external wiring, dangerous voltages (115 V, 220 V or 230 V) may be present on the terminals of relay outputs RO1 to RO3.
- ACS800-02 with enclosure extension: The main switch on the cabinet door does not remove the voltage from the input busbars of the drive. Before working on the drive, isolate the whole drive from the supply.
- ACS800-04M, ACS800-07: The Prevention of Unexpected Start function does not remove the voltage from the main and auxiliary circuits.
- At installation sites above 2000 m (6562 ft), the terminals of the RMIO board and optional modules attached to the board do not fulfil the Protective Extra Low Voltage (PELV) requirements stated in EN 50178.

Grounding

These instructions are intended for all who are responsible for the grounding of the drive.



WARNING! Ignoring the following instructions can cause physical injury, death, increased electromagnetic interference and equipment malfunction:

- Ground the drive, motor and adjoining equipment to ensure personnel safety in all circumstances, and to reduce electromagnetic emission and pick-up.
- Make sure that grounding conductors are adequately sized as required by safety regulations.
- In a multiple-drive installation, connect each drive separately to protective earth (PE).
- ACS800-01, ACS800-11, ACS800-31: In European CE compliant installations and in other installations where EMC emissions must be minimized, make a 360° high frequency grounding of cable entries in order to suppress electromagnetic disturbances. In addition, connect the cable shields to protective earth (PE) in order to meet safety regulations.

ACS800-04 (45 to 560 kW) and ACS800-02 in first environment: make a 360° high frequency grounding of motor cable entries at the cabinet lead-through.

- Do not install a drive with EMC filter option +E202 or +E200 (available for ACS800-01 and ACS800-11, ACS800-31 only) on an ungrounded power system or a high-resistance-grounded (over 30 ohms) power system.

Note:

- Power cable shields are suitable for equipment grounding conductors only when adequately sized to meet safety regulations.
 - As the normal leakage current of the drive is higher than 3.5 mA AC or 10 mA DC (stated by EN 50178, 5.2.11.1), a fixed protective earth connection is required.
-

Mechanical installation and maintenance

These instructions are intended for all who install and service the drive.



WARNING! Ignoring the following instructions can cause physical injury or death, or damage to the equipment:

- Handle the unit carefully.
- ACS800-01, ACS800-11, ACS800-31: The drive is heavy. Do not lift it alone. Do not lift the unit by the front cover. Place the unit only on its back.

ACS800-02, ACS800-04: The drive is heavy. Lift the drive by the lifting lugs only. Do not tilt the unit. The unit will overturn from a tilt of about 6 degrees. Use extreme caution when manoeuvring a drive that runs on wheels. **An overturning unit can cause physical injury.**

Do not tilt!

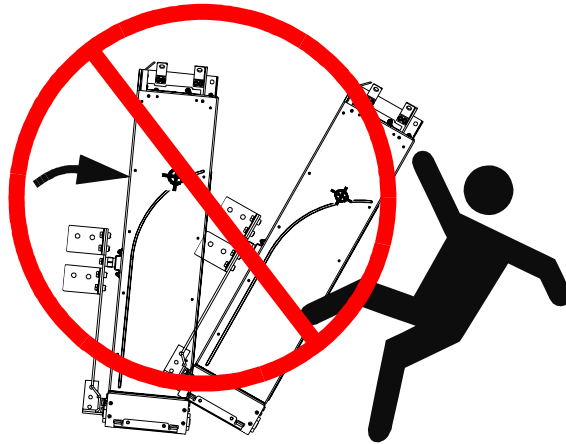

- Beware of hot surfaces. Some parts, such as heatsinks of power semiconductors, remain hot for a while after disconnection of the electrical supply.
- Make sure that dust from drilling does not enter the drive when installing. Electrically conductive dust inside the unit may cause damage or malfunctioning.
- Ensure sufficient cooling.
- Do not fasten the drive by riveting or welding.

Printed circuit boards



WARNING! Ignoring the following instructions can cause damage to the printed circuit boards:

- The printed circuit boards contain components sensitive to electrostatic discharge. Wear a grounding wrist band when handling the boards. Do not touch the boards unnecessarily.
-

Fibre optic cables



WARNING! Ignoring the following instructions can cause equipment malfunction and damage to the fibre optic cables:



- Handle the fibre optic cables with care. When unplugging optic cables, always grab the connector, not the cable itself. Do not touch the ends of the fibres with bare hands as the fibre is extremely sensitive to dirt. The minimum allowed bend radius is 35 mm (1.4 in.).
-

Operation

These warnings are intended for all who plan the operation of the drive or operate the drive.



WARNING! Ignoring the following instructions can cause physical injury or death, or damage to the equipment:

- Before adjusting the drive and putting it into service, make sure that the motor and all driven equipment are suitable for operation throughout the speed range provided by the drive. The drive can be adjusted to operate the motor at speeds above and below the speed provided by connecting the motor directly to the power line.
- Do not activate automatic fault reset functions of the Standard Application Program if dangerous situations can occur. When activated, these functions will reset the drive and resume operation after a fault.
- Do not control the motor with the disconnecting device (disconnecting means); instead, use the control panel keys  and , or commands via the I/O board of the drive. The maximum allowed number of charging cycles of the DC capacitors (i.e. power-ups by applying power) is five in ten minutes.
- ACS800-04M, ACS800-07: Do not use the optional Prevention of Unexpected Start function for stopping the drive when the drive is running. Give a Stop command instead.

Note:

- If an external source for start command is selected and it is ON, the drive (with Standard Application Program) will start immediately after fault reset unless the drive is configured for 3-wire (a pulse) start/stop.
 - When the control location is not set to Local (L not shown in the status row of the display), the stop key on the control panel will not stop the drive. To stop the drive using the control panel, press the LOC/REM key and then the stop key .
-

Permanent magnet motor

These are additional warnings concerning permanent magnet motor drives. Ignoring the instructions can cause physical injury or death, or damage to the equipment.

Installation and maintenance work



WARNING! Do not work on the drive when the permanent magnet motor is rotating. Also, when the supply power is switched off and the inverter is stopped, a rotating permanent magnet motor feeds power to the intermediate circuit of the drive and the supply connections become live.

Before installation and maintenance work on the drive:

- Stop the motor.
 - Ensure that the motor cannot rotate during work.
 - Ensure that there is no voltage on the drive power terminals:
Alternative 1) Disconnect the motor from the drive with a safety switch or by other means. Measure that there is no voltage present on the drive input or output terminals (U1, V1, W1, U2, V2, W2, UDC+, UDC-).
Alternative 2) Measure that there is no voltage present on the drive input or output terminals (U1, V1, W1, U2, V2, W2, UDC+, UDC-). Ground the drive output terminals temporarily by connecting them together as well as to the PE.
Alternative 3) If possible, both of the above.
-

Start-up and operation



WARNING! Do not run the motor over the rated speed. Motor overspeed leads to overvoltage which may damage or explode the capacitors in the intermediate circuit of the drive.

Controlling a permanent magnet motor is only allowed using the ACS800 Permanent Magnet Synchronous Motor Drive Application Program, or other application programs in scalar control mode.

Table of contents

ACS800 Single Drive Manuals	2
-----------------------------------	---

Safety instructions

What this chapter contains	5
To which products this chapter applies	5
Use of warnings and notes	5
Installation and maintenance work	6
Grounding	7
Mechanical installation and maintenance	8
Printed circuit boards	9
Fibre optic cables	9
Operation	10
Permanent magnet motor	11
Installation and maintenance work	11
Start-up and operation	11

Table of contents

About this manual

What this chapter contains	19
Intended audience	19
Common chapters for several products	19
Categorization according to the frame size	19
Categorization according to the + code	19
Contents	20
Installation and commissioning flowchart	21
Inquiries	22

The ACS800-01/U1

What this chapter contains	23
The ACS800-01/U1	23
Type code	24
Main circuit and control	25
Diagram	25
Operation	25
Printed circuit boards	26
Motor control	26

Mechanical installation

Unpacking the unit	27
Delivery check	28

Before installation	.28
Requirements for the installation site	.28
Wall	.28
Floor	.28
Free space around the unit	.29
Mounting the drive on the wall	.30
Units without vibration dampers	.30
IP 55 (UL type 12) marine applications (+C132) of frame sizes R4 to R6	.30
Units with vibration dampers (+C131)	.30
UL 12 units	.30
Cabinet installation	.31
Preventing cooling air recirculation	.31
Unit above another	.32

Planning the electrical installation

What this chapter contains	.33
To which products this chapter applies	.33
Motor selection and compatibility	.33
Protecting the motor insulation and bearings	.35
Requirements table	.36
Permanent magnet synchronous motor	.38
Supply connection	.39
Disconnecting device (disconnecting means)	.39
ACS800-01, ACS800-U1, ACS800-11, ACS800-U11, ACS800-31, ACS800-U31,	
ACS800-02 and ACS800-U2 without enclosure extension, ACS800-04, ACS800-U4	.39
ACS800-02 and ACS800-U2 with enclosure extension, ACS800-07 and ACS800-U7	.39
EU	.39
US	.39
Fuses	.39
Thermal overload and short-circuit protection	.40
Thermal overload protection	.40
Short-circuit protection	.41
Ground fault protection	.43
Emergency stop devices	.43
ACS800-02/U2 with enclosure extension and ACS800-07/U7	.43
Restarting after an emergency stop	.43
Prevention of Unexpected Start	.44
Selecting the power cables	.45
General rules	.45
Alternative power cable types	.46
Motor cable shield	.46
Additional US requirements	.47
Conduit	.47
Armored cable / shielded power cable	.47
Power factor compensation capacitors	.47
Equipment connected to the motor cable	.48
Installation of safety switches, contactors, connection boxes, etc.	.48
Bypass connection	.48
Before opening a contactor (DTC control mode selected)	.48

Protecting the relay output contacts and attenuating disturbances in case of inductive loads	49
Selecting the control cables	50
Relay cable	50
Control panel cable	50
Connection of a motor temperature sensor to the drive I/O	51
Installation sites above 2000 metres (6562 feet)	51
Routing the cables	51
Control cable ducts	52

Electrical installation

What this chapter contains	53
Checking the insulation of the assembly	54
Drive	54
Input cable	54
Motor and motor cable	54
IT (ungrounded) systems	54
Connecting the power cables	55
Diagram	55
Conductor stripping lengths	56
Allowed wire sizes, tightening torques	56
Wall installed units (European version)	56
Power cable installation procedure	56
Wall installed units (US version)	60
Warning sticker	61
Cabinet installation (IP 21, UL type 1)	61
Frame size R5	62
Frame size R6	63
Connecting the control cables	64
Terminals	64
360 degrees grounding	66
When the outer surface of the shield is covered with non-conductive material	66
Connecting the shield wires	66
Cabling of I/O and fieldbus modules	67
Pulse encoder module cabling	67
Fastening the control cables and covers	68
Installation of optional modules and PC	68
Fibre optic link	68

Motor control and I/O board (RMIO)

What this chapter contains	69
To which products this chapter applies	69
Note for the ACS800-02 with enclosure extension and the ACS800-07	69
Note on terminal labelling	69
Note on external power supply	70
Parameter settings	70
External control connections (non-US)	71
External control connections (US)	72

RMIO board specifications	73
Analogue inputs	73
Constant voltage output	73
Auxiliary power output	73
Analogue outputs	73
Digital inputs	73
Relay outputs	74
DDCS fibre optic link	74
24 VDC power input	74

Installation checklist

Checklist	77
-----------	----

Maintenance

What this chapter contains	79
Safety	79
Maintenance intervals	79
Heatsink	80
Fan	80
Fan replacement (R2, R3)	80
Fan replacement (R4)	81
Fan replacement (R5)	82
Fan replacement (R6)	83
Additional fan	83
Replacement (R2, R3)	83
Replacement (R4, R5)	83
Replacement (R6)	84
Capacitors	84
Reforming	84
LEDs	84

Technical data

What this chapter contains	85
IEC data	85
Ratings	85
Symbols	87
Sizing	87
Derating	87
Temperature derating	87
Altitude derating	87
Mains cable fuses	88
Cable types	90
Cable entries	90
Dimensions, weights and noise	91

NEMA data	92
Ratings	92
Symbols	93
Input cable fuses	93
Cable types	95
Cable Entries	95
Dimensions, weights and noise	96
Input power connection	96
Motor connection	96
Efficiency	97
Cooling	97
Degrees of protection	97
Ambient conditions	98
Materials	99
Applicable standards	99
CE marking	100
Definitions	100
EN 61800-3 + Amendment A11 (2000)	100
EN 61800-3 (2004)	100
Compliance with the EMC Directive	100
Compliance with the EN 61800-3 + Amendment A11 (2000) and EN 61800-3 (2004)	100
First environment (restricted distribution, drive of category C2)	100
Second environment (drive of category C3)	101
Second environment (drive of category C4)	101
Machinery Directive	101
“C-tick” marking	102
Definitions	102
Compliance with IEC 61800-3	102
First environment (drive of category C2)	102
Second environment (drive of category C3)	103
Second environment (drive of category C4)	103
Marine type approvals	103
UL/CSA markings	104
UL	104
Equipment warranty and liability	104

Dimensional drawings

Frame size R2 (IP 21, UL type 1)	106
Frame size R2 (IP 55, UL type 12)	107
Frame size R3 (IP 21, UL type 1)	108
Frame size R3 (IP 55, UL type 12)	109
Frame size R4 (IP 21, UL type 1)	110
Frame size R4 (IP 55, UL type 12)	111
Frame size R5 (IP 21, UL type 1)	112
Frame size R5 (IP 55, UL type 12)	113
Frame size R6 (IP 21, UL type 1)	114
Frame size R6 (IP 55, UL type 12)	115

Dimensional drawings (USA)	116
Frame size R2 (UL type 1, IP 21)	117
Frame size R2 (UL type 12, IP 55)	118
Frame size R3 (UL type 1, IP 21)	119
Frame size R3 (UL type 12, IP 55)	120
Frame size R4 (UL type 1, IP 21)	121
Frame size R4 (UL type 12, IP 55)	122
Frame size R5 (UL type 1, IP 21)	123
Frame size R5 (UL type 12, IP 55)	124
Frame size R6 (UL type 1, IP 21)	125
Frame size R6 (UL type 12, IP 55)	126

Resistor braking

What this chapter contains	127
To which products this chapter applies	127
Availability of brake choppers and resistors for the ACS800	127
How to select the correct drive/chopper/resistor combination	127
Optional brake chopper and resistor(s) for the ACS800-01/U1	128
Optional brake chopper and resistor(s) for the ACS800-02/U2, ACS800-04/04M/U4 and ACS800-07/U7	130
Resistor installation and wiring	132
ACS800-07/U7	133
Protection of frame sizes R2 to R5 (ACS800-01/U1)	133
Protection of frame size R6 (ACS800-01, ACS800-07) and frame sizes R7 and R8 (ACS800-02, ACS800-04, ACS800-07)	133
Brake circuit commissioning	134

External +24 V power supply for the RMIO board via terminal X34

What this chapter contains	135
Parameter settings	135
Connecting +24 V external power supply	136

About this manual

What this chapter contains

This chapter describes the intended audience and contents of this manual. It contains a flowchart of steps in checking the delivery, installing and commissioning the drive. The flowchart refers to chapters/sections in this manual and other manuals.

Intended audience

This manual is intended for people who plan the installation, install, commission, use and service the drive. Read the manual before working on the drive. The reader is expected to know the fundamentals of electricity, wiring, electrical components and electrical schematic symbols.

This manual is written for readers worldwide. Both SI and imperial units are shown. Special US instructions for installations within the United States that must be installed per the National Electrical Code and local codes are marked with (US).

Common chapters for several products

Chapters [Safety instructions](#), [Planning the electrical installation](#), [Motor control and I/O board \(RMIO\)](#) and [Resistor braking](#) apply to several ACS800 products which are listed at the beginning of the chapters.

Categorization according to the frame size

Some instructions, technical data and dimensional drawings which concern only certain frame sizes are marked with the symbol of the frame size R2, R3... or R8. The frame size is not marked on the drive designation label. To identify the frame size of your drive, see the rating tables in chapter [Technical data](#).

The ACS800-01 is manufactured in frame sizes R2 to R6.

Categorization according to the + code

The instructions, technical data and dimensional drawings which concern only certain optional selections are marked with + codes, e.g. +E202. The options included in the drive can be identified from the + codes visible on the type designation label of the drive. The + code selections are listed in chapter [The ACS800-01/U1](#) under [Type code](#).

Contents

The chapters of this manual are briefly described below.

Safety instructions give safety instructions for the installation, commissioning, operation and maintenance of the drive.

About this manual lists the steps in checking the delivery and installing and commissioning the drive and refers to chapters/sections in this manual and other manuals for particular tasks.

The ACS800-01/U1 describes the drive.

Mechanical installation instructs how to place and mount the drive.

Planning the electrical installation instructs on the motor and cable selection, protections and cable routing.

Electrical installation shows how to wire the drive.

Motor control and I/O board (RMIO) shows the external control connections to the I/O board.

Installation checklist contains a list for checking the mechanical and electrical installation of the drive.

Maintenance contains preventive maintenance instructions.

Technical data contains the technical specifications of the drive, e.g. the ratings, sizes and technical requirements, provisions for fulfilling the requirements for CE and other markings and warranty policy.

Dimensional drawings contains the dimensional drawings of the drive.

Resistor braking describes how to select, protect and wire brake choppers and resistors. The chapter also contains the technical data.

External +24 V power supply for the RMIO board via terminal X34 describes how to connect an external +24 V power supply for the RMIO board using terminal X34.

Installation and commissioning flowchart

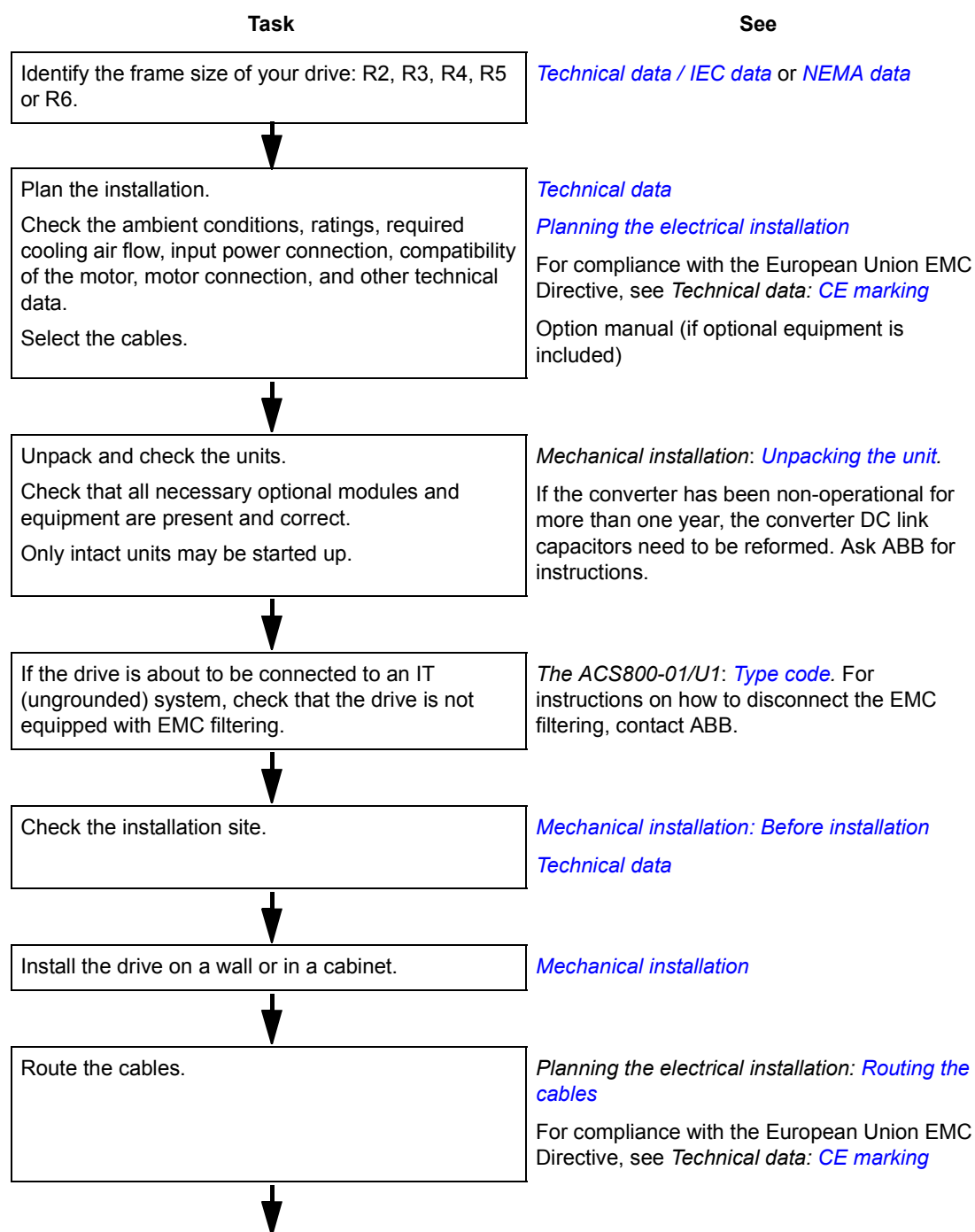

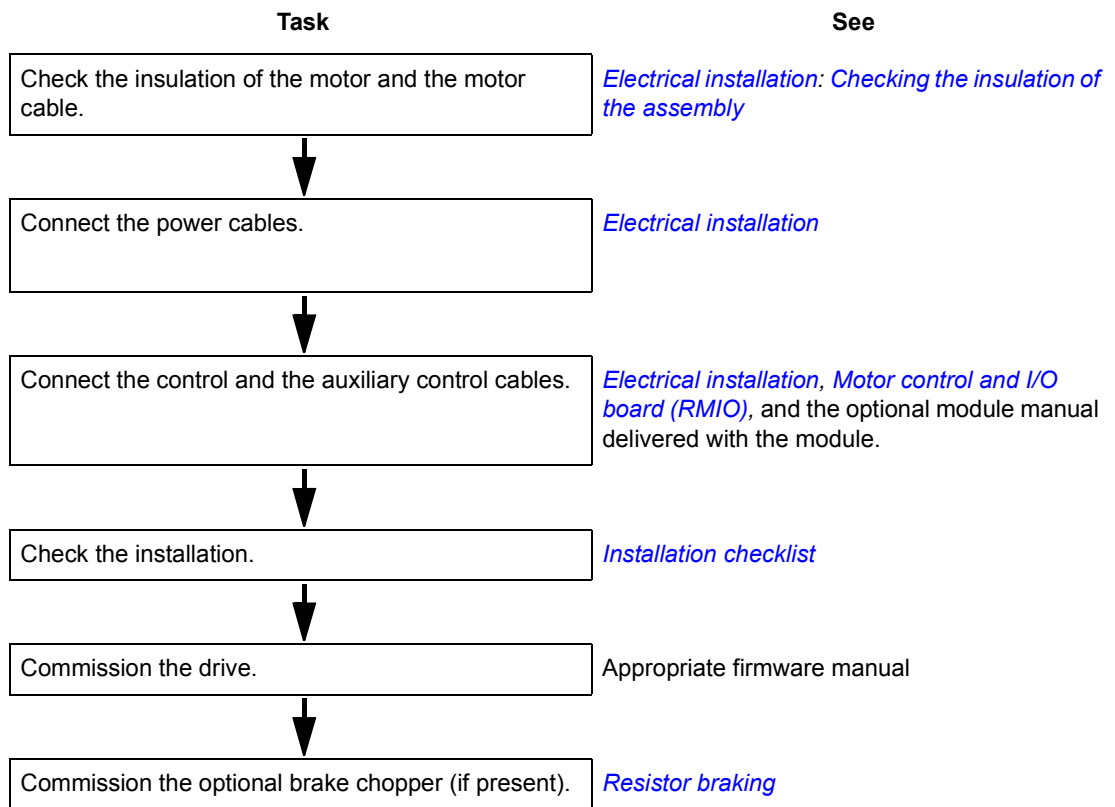

Inquiries

Address any inquiries about the product to the local ABB representative, quoting the type code and the serial number of the unit. If the local ABB representative cannot be contacted, address inquiries to the manufacturing facility.

The ACS800-01/U1

What this chapter contains

This chapter describes the operating principle and construction of the drive in short.

The ACS800-01/U1

The ACS800-01/U1 is a wall mountable drive for controlling AC motors.

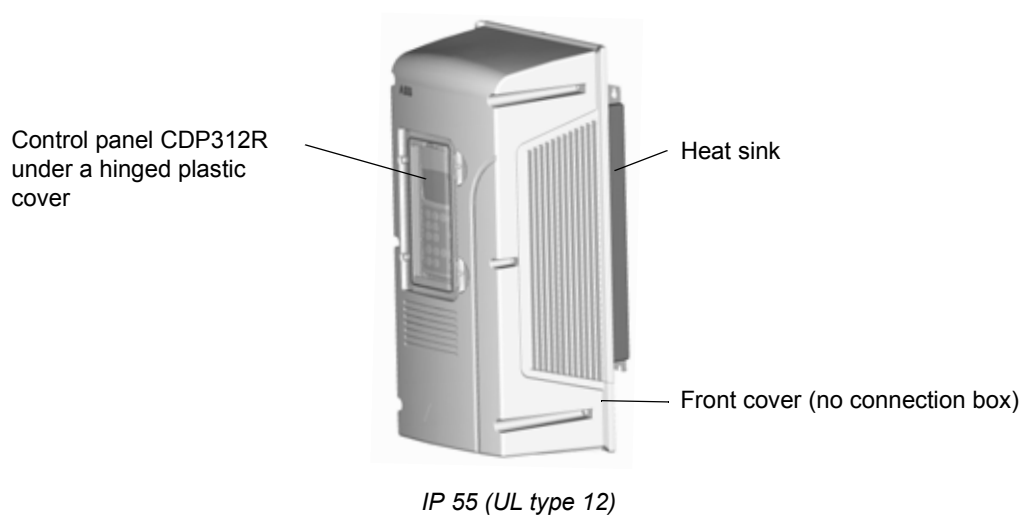
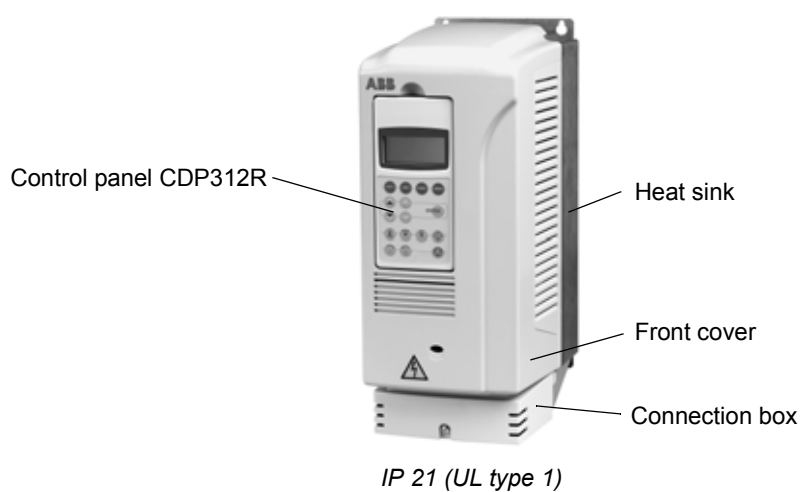

Type code

The type code contains information on the specifications and configuration of the drive. The first digits from left express the basic configuration (e.g. ACS800-01-0006-5). The optional selections are given thereafter, separated by + signs (e.g. +E202). The main selections are described below. Not all selections are available for all types. For more information, refer to *ACS800 Ordering Information* (EN code: 64556568, available on request).

Selection	Alternatives	
Product series	ACS800 product series	
Type	01	wall mounted. When no options are selected: IP 21, Control Panel CDP312R, no EMC filter, Standard Application Program, cable connection box (cabling from below), brake chopper in frame sizes R2 and R3 (230/400/500 V units) and in frame size R4 (690 V units), boards without coating, one set of manuals.
	U1	wall mounted (USA). When no options are selected: UL type 1, Control Panel CDP312R, no EMC filter, US version of the Standard Application Program (three-wire start/stop as default setting), US gland/conduit box, brake chopper in frame sizes R2 and R3 (230/400/500 V units) and in frame size R4 (690 V units), boards without coating, one set of English manuals.
Size	Refer to <i>Technical data: IEC data</i> .	
Voltage range (nominal rating in bold)	2	208/220/ 230 /240 VAC
	3	380/ 400 /415 VAC
	5	380/400/415/440/460/480/ 500 VAC
	7	525/575/600/ 690 VAC
+ options		
Degree of protection	B056	IP 55 / UL type 12
Construction	C131	vibration dampers
	C132	marine type approved unit (coated boards included, +C131 required for frame sizes R4 to R6 in wall installations, +C131 not required in cabinet installations)
Resistor braking	D150	brake chopper
Filter	E200	EMC/RFI filter for second environment TN (grounded) system, unrestricted distribution, drive category C3
	E202	EMC/RFI filter for first environment TN (grounded) system, restricted distribution, drive category C2
Cabling	H358	US/UK gland/conduit box
Control panel	OJ400	no control panel
Fieldbus	K...	Refer to <i>ACS800 Ordering Information</i> (EN code: 64556568).
I/O	L...	
Application program	N...	
Manual language	R...	
Specialities	P901	

Main circuit and control

Diagram

This diagram shows the control interfaces and the main circuit of the drive.

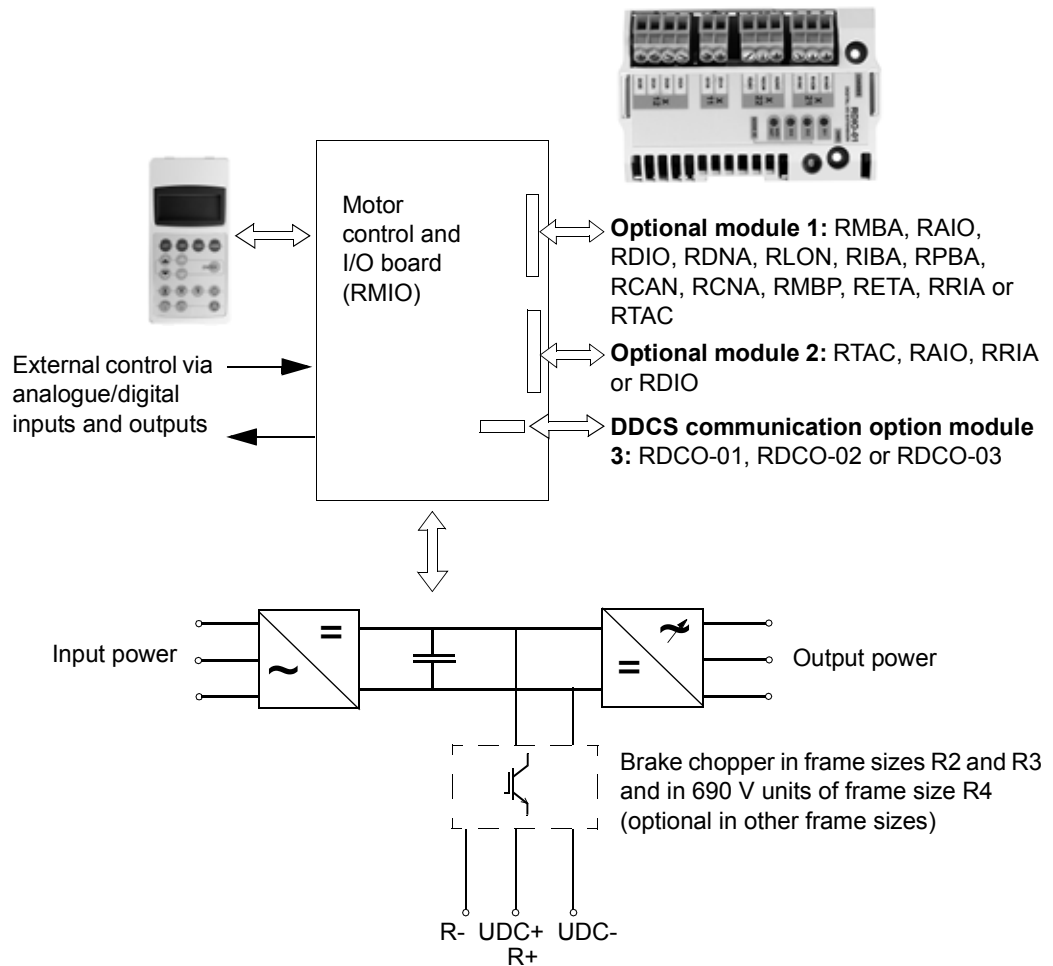

Operation

This table describes the operation of the main circuit in short.

Component	Description
six-pulse rectifier	converts the three-phase AC voltage to DC voltage
capacitor bank	energy storage which stabilizes the intermediate circuit DC voltage
IGBT inverter	converts the DC voltage to AC voltage and vice versa. The motor operation is controlled by switching the IGBTs.

Printed circuit boards

The drive contains the following printed circuit boards as standard:

- main circuit board (RINT)
- motor control and I/O board (RMIO)
- EMC filter board (RRFC) when EMC equipment is selected or varistor board (RVAR) otherwise
- control panel (CDP 312R).

Motor control

The motor control is based on the Direct Torque Control (DTC) method. Two phase currents and DC link voltage are measured and used for the control. The third phase current is measured for earth fault protection.

Mechanical installation

Unpacking the unit

The drive is delivered in a box that also contains:

- plastic bag containing: screws (M3), clamps and cable lugs (2 mm², M3) for grounding the control cable screens
- connection box (screws, clamps and vibration dampers with +C131 included)
- residual voltage warning stickers
- hardware manual
- appropriate firmware manuals and guides
- optional module manuals
- delivery documents.

Unpack the unit of frame sizes R2 to R5 (IP 21, UL type 1) as follows.



Delivery check

Check that there are no signs of damage. Before attempting installation and operation, check the information on the type designation label of the drive to verify that the unit is of the correct type. The label includes an IEC and NEMA rating, UL, C-UL, CSA and CE markings, a type code and a serial number, which allow individual recognition of each unit. The first digit of the serial number refers to the manufacturing plant. The next four digits refer to the unit's manufacturing year and week, respectively. The remaining digits complete the serial number so that there are no two units with the same serial number.

The type designation label is attached to the heat sink and the serial number label to the upper part of the back plate of the unit. Example labels are shown below.



Type designation label



Serial number label

Before installation

The drive must be installed in an upright position with the cooling section facing a wall. Check the installation site according to the requirements below. Refer to [Dimensional drawings](#) for frame details.

Requirements for the installation site

See [Technical data](#) for the allowed operation conditions of the drive.

Wall

The wall should be as close to vertical as possible, of non-flammable material and strong enough to carry the weight of the unit. Check that there is nothing on the wall to inhibit the installation.

Floor

The floor/material below the installation should be non-flammable.

Free space around the unit

Required free space around the drive to enable cooling air flow, service and maintenance is shown below in millimetres and [inches]. When mounting IP 55 units above one another, leave 200 mm (7.9 in.) free space above and below the unit.

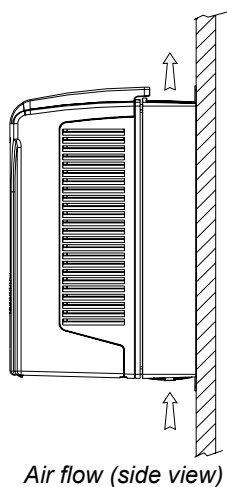
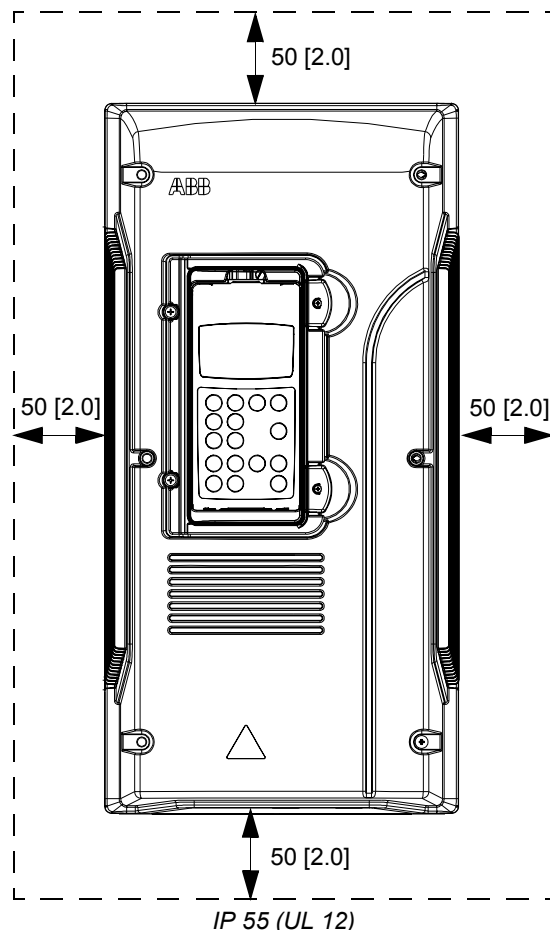
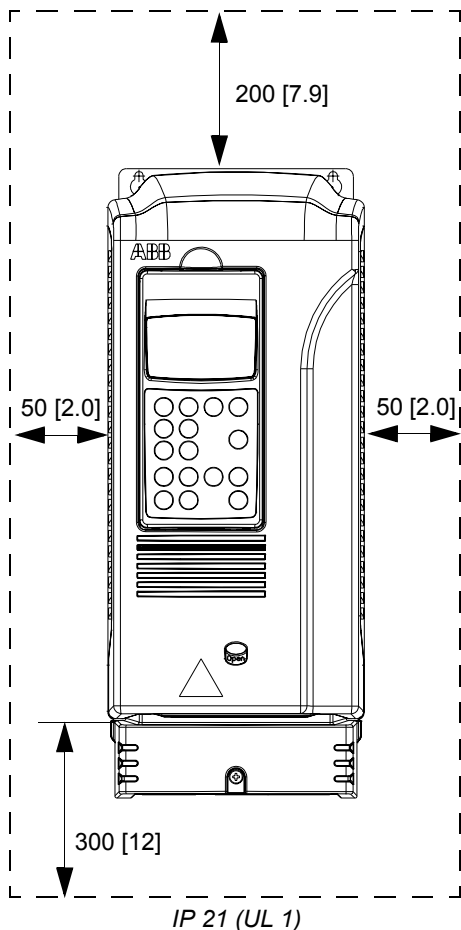

Mounting the drive on the wall

Units without vibration dampers

1. Mark the locations for the four holes. The mounting points are shown in [Dimensional drawings](#). In frame sizes R2 to R5 (IP 21, UL type 1), use the mounting template cut from the package.
2. Fix the screws or bolts to the marked locations.
3. IP 55 (UL type 12) units: Remove the front cover by undoing the fixing screws.
4. Position the drive onto the screws on the wall. **Note:** Lift the drive by its chassis (R6: by its lifting holes), not by its cover.
5. Tighten the screws in the wall securely.

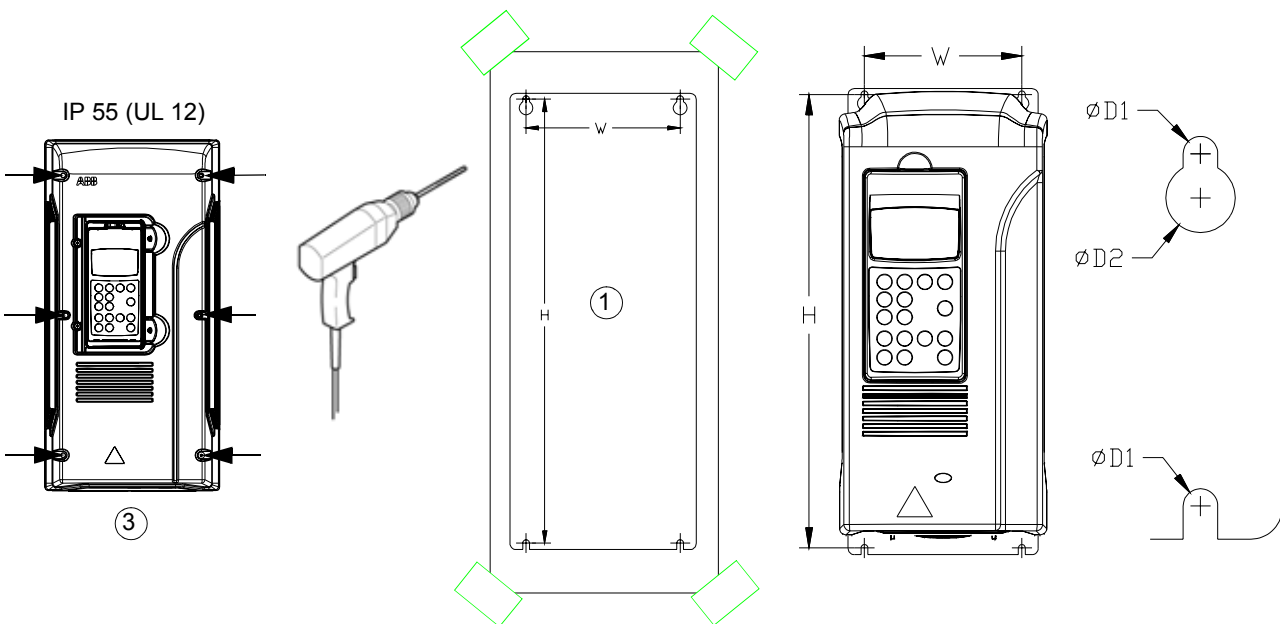

IP 55 (UL type 12) marine applications (+C132) of frame sizes R4 to R6

See ACS800-01/U1 Marine Supplement [3AFE68291275 (English)].

Units with vibration dampers (+C131)

See ACS800-01/U1 Vibration Damper Installation Guide [3AFE68295351 (English)].

UL 12 units

Install the hood delivered with the drive 50 mm (2.0 in.) above the top of unit.

Cabinet installation

The required distance between parallel units is five millimetres (0.2 in.) in installations without the front cover. The cooling air entering the unit must not exceed +40 °C (+104 °F).

Preventing cooling air recirculation

Prevent air recirculation inside and outside the cabinet.

Example

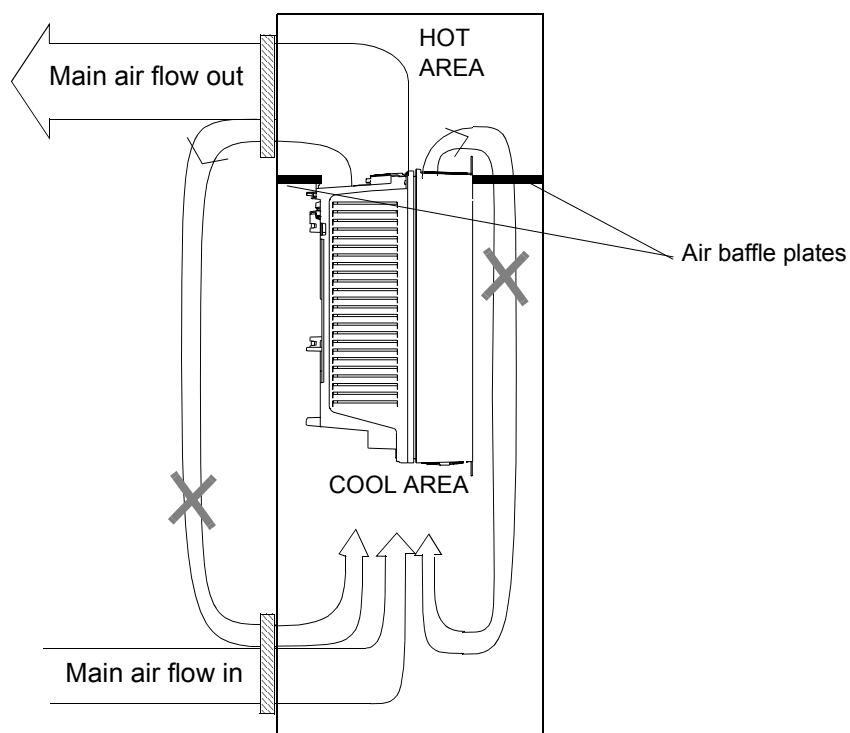

Unit above another

Lead the out-coming cooling air away from the unit above.

Example

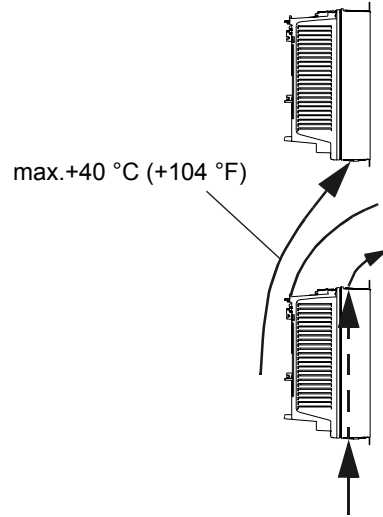

Planning the electrical installation

What this chapter contains

This chapter contains the instructions that you must follow when selecting the motor, cables, protections, cable routing and way of operation for the drive system.

Note: The installation must always be designed and made according to applicable local laws and regulations. ABB does not assume any liability whatsoever for any installation which breaches the local laws and/or other regulations. Furthermore, if the recommendations given by ABB are not followed, the drive may experience problems that the warranty does not cover.

To which products this chapter applies

This chapter applies to the ACS800-01/U1, ACS800-11/U11, ACS800-31/U31, ACS800-02/U2, ACS800-04/U4, and ACS800-07/U7 types up to -0610-x.

Note: All options described in this chapter are not available for all products. Check the availability from section *Type code* on page [24](#).

Motor selection and compatibility

1. Select the motor according to the rating tables in chapter *Technical Data*. Use the DriveSize PC tool if the default load cycles are not applicable.
2. Check that the motor ratings lie within the allowed ranges of the drive control program:
 - motor nominal voltage is $1/2 \dots 2 \cdot U_N$ of the drive
 - motor nominal current is $1/6 \dots 2 \cdot I_{2hd}$ of the drive in DTC control and $0 \dots 2 \cdot I_{2hd}$ in scalar control. The control mode is selected by a drive parameter.

3. Check that the motor voltage rating meets the application requirements:

If the drive is equipped with and then the motor voltage rating should be ...
diode supply ACS800-01, -U1, -02, -U2, -04, -04M, -U4 -07, -U7	no resistor braking is in use	U_N
	frequent or long term brake cycles will be used	U_{ACeq1}
IGBT supply ACS800-11, -U11, -17	DC link voltage will not be increased from nominal (parameter setting)	U_N
	DC link voltage will be increased from nominal (parameter setting)	U_{ACeq2}

U_N = Rated input voltage of the drive

U_{ACeq1} = $U_{DC}/1.35$

U_{ACeq2} = $U_{DC}/1.41$

U_{ACeq} is the equivalent AC power source voltage of the drive in VAC.

U_{DC} is the maximum DC link voltage of the drive in VDC.

For resistor braking: $U_{DC} = 1.21 \times$ nominal DC link voltage.

For units with IGBT supply: See the parameter value.

(**Note:** Nominal DC link voltage is $U_N \times 1.35$ or $U_N \times 1.41$ in VDC.)

See notes 6 and 7 below the [Requirements table](#), pages 37 and 38.

- Consult the motor manufacturer before using a motor in a drive system where the motor nominal voltage differs from the AC power source voltage.
- Ensure that the motor insulation system withstands the maximum peak voltage in the motor terminals. See the [Requirements table](#) below for the required motor insulation system and drive filtering.

Example 1: When the supply voltage is 440 V and a drive with a diode supply is operating in motor mode only, the maximum peak voltage in the motor terminals can be approximated as follows: $440 \text{ V} \cdot 1.35 \cdot 2 = 1190 \text{ V}$. Check that the motor insulation system withstands this voltage.

Example 2: When the supply voltage is 440 V and the drive is equipped with an IGBT supply, the maximum peak voltage in the motor terminals can be approximated as follows: $440 \text{ V} \cdot 1.41 \cdot 2 = 1241 \text{ V}$. Check that the motor insulation system withstands this voltage.

Protecting the motor insulation and bearings

The output of the drive comprises – regardless of output frequency – pulses of approximately 1.35 times the equivalent mains network voltage with a very short rise time. This is the case with all drives employing modern IGBT inverter technology.

The voltage of the pulses can be almost double at the motor terminals, depending on the attenuation and reflection properties of the motor cable and the terminals. This in turn can cause additional stress on the motor and motor cable insulation.

Modern variable speed drives with their fast rising voltage pulses and high switching frequencies can generate current pulses that flow through the motor bearings, which can gradually erode the bearing races and rolling elements.

The stress on motor insulation can be avoided by using optional ABB du/dt filters. du/dt filters also reduce bearing currents.

To avoid damage to motor bearings, the cables must be selected and installed according to the instructions given in the hardware manual. In addition, insulated N-end (non-driven end) bearings and output filters from ABB must be used according to the following table. Two types of filters are used individually or in combinations:

- optional du/dt filter (protects motor insulation system and reduces bearing currents).
- common mode filter (mainly reduces bearing currents).

Requirements table

The following table shows how to select the motor insulation system and when an optional ABB du/dt filter, insulated N-end (non-driven end) motor bearings and ABB common mode filters are required. The motor manufacturer should be consulted regarding the construction of the motor insulation and additional requirements for explosion-safe (EX) motors. Failure of the motor to fulfil the following requirements or improper installation may shorten motor life or damage the motor bearings.

Manufacturer	Motor type	Nominal mains voltage (AC line voltage)	Requirement for			
			Motor insulation system	ABB du/dt filter, insulated N-end bearing and ABB common mode filter		
				$P_N < 100 \text{ kW}$ and frame size < IEC 315	$100 \text{ kW} \leq P_N < 350 \text{ kW}$ or frame size \geq IEC 315	$P_N \geq 350 \text{ kW}$ or frame size \geq IEC 400
			$P_N < 134 \text{ HP}$ and frame size < NEMA 500	$134 \text{ HP} \leq P_N < 469 \text{ HP}$ or frame size \geq NEMA 500	$P_N \geq 469 \text{ HP}$ or frame size > NEMA 580	
A B B	Random-wound M2_ and M3_	$U_N \leq 500 \text{ V}$	Standard	-	+ N	+ N + CMF
		$500 \text{ V} < U_N \leq 600 \text{ V}$	Standard	+ du/dt	+ du/dt + N	+ du/dt + N + CMF
			or			
		Reinforced	-	+ N	+ N + CMF	
	$600 \text{ V} < U_N \leq 690 \text{ V}$	Reinforced	+ du/dt	+ du/dt + N	+ du/dt + N + CMF	
	Form-wound HX_ and AM_	$380 \text{ V} < U_N \leq 690 \text{ V}$	Standard	n.a.	+ N + CMF	$P_N < 500 \text{ kW}$: + N + CMF $P_N \geq 500 \text{ kW}$: + N + CMF + du/dt
Old* form-wound HX_ and modular	$380 \text{ V} < U_N \leq 690 \text{ V}$	Check with the motor manufacturer.	+ du/dt with voltages over 500 V + N + CMF			
Random-wound HX_ and AM_**	$0 \text{ V} < U_N \leq 500 \text{ V}$	Enamelled wire with fibre glass taping	+ N + CMF			
	$500 \text{ V} < U_N \leq 690 \text{ V}$		+ du/dt + N + CMF			
N O N - A B B	Random-wound and form-wound	$U_N \leq 420 \text{ V}$	Standard: $\hat{U}_{LL} = 1300 \text{ V}$	-	+ N or CMF	+ N + CMF
		$420 \text{ V} < U_N \leq 500 \text{ V}$	Standard: $\hat{U}_{LL} = 1300 \text{ V}$	+ du/dt	+ du/dt + N	+ du/dt + N + CMF
				or	+ du/dt + CMF	
		or				
	Reinforced: $\hat{U}_{LL} = 1600 \text{ V}$, 0.2 microsecond rise time	-	+ N or CMF	+ N + CMF		
	$500 \text{ V} < U_N \leq 600 \text{ V}$	Reinforced: $\hat{U}_{LL} = 1600 \text{ V}$	+ du/dt	+ du/dt + N	+ du/dt + N + CMF	
			or	+ du/dt + CMF		
		or				
Reinforced: $\hat{U}_{LL} = 1800 \text{ V}$	-	+ N or CMF	+ N + CMF			
$600 \text{ V} < U_N \leq 690 \text{ V}$	Reinforced: $\hat{U}_{LL} = 1800 \text{ V}$	+ du/dt	+ du/dt + N	+ du/dt + N + CMF		
	Reinforced: $\hat{U}_{LL} = 2000 \text{ V}$, 0.3 microsecond rise time ***	-	N + CMF	N + CMF		

* manufactured before 1.1.1998

** For motors manufactured before 1.1.1998, check for additional instructions with the motor manufacturer.

*** If the intermediate DC circuit voltage of the drive is increased from the nominal level by resistor braking or by the IGBT supply unit control program (parameter selectable function), check with the motor manufacturer if additional output filters are needed in the applied drive operation range.

Note 1: The abbreviations used in the table are defined below.

Abbreviation	Definition
U_N	nominal voltage of the supply network
\hat{U}_{LL}	peak line-to-line voltage at motor terminals which the motor insulation must withstand
P_N	motor nominal power
du/dt	du/dt filter at the output of the drive +E205
CMF	common mode filter +E208
N	N-end bearing: insulated motor non-driven end bearing
n.a.	Motors of this power range are not available as standard units. Consult the motor manufacturer.

Note 2: *Explosion-safe (EX) motors*

The motor manufacturer should be consulted regarding the construction of the motor insulation and additional requirements for explosion-safe (EX) motors.

Note 3: *High-output motors and IP 23 motors*

For motors with higher rated output than what is stated for the particular frame size in EN 50347 (2001) and for IP 23 motors, the requirements of ABB random-wound motor series M3AA, M3AP, M3BP are given below. For other motor types, see the [Requirements table](#) above. Apply the requirements of range $100 \text{ kW} < P_N < 350 \text{ kW}$ to motors with $P_N < 100 \text{ kW}$. Apply the requirements of range $P_N \geq 350 \text{ kW}$ to motors within the range $100 \text{ kW} < P_N < 350 \text{ kW}$. In other cases, consult the motor manufacturer.

Manufacturer	Motor type	Nominal mains voltage (AC line voltage)	Requirement for			
			Motor insulation system	ABB du/dt filter, insulated N-end bearing and ABB common mode filter		
				$P_N < 55 \text{ kW}$	$55 \text{ kW} \leq P_N < 200 \text{ kW}$	$P_N \geq 200 \text{ kW}$
				$P_N < 74 \text{ HP}$	$74 \text{ HP} \leq P_N < 268 \text{ HP}$	$P_N \geq 268 \text{ HP}$
A B B	Random-wound M3AA, M3AP, M3BP	$U_N \leq 500 \text{ V}$	Standard	-	+ N	+ N + CMF
		$500 \text{ V} < U_N \leq 600 \text{ V}$	Standard	+ du/dt	+ du/dt + N	+ du/dt + N + CMF
			or			
		Reinforced	-	+ N	+ N + CMF	
	$600 \text{ V} < U_N \leq 690 \text{ V}$	Reinforced	+ du/dt	+ du/dt + N	+ du/dt + N + CMF	

Note 4: *HXR and AMA motors*

All AMA machines (manufactured in Helsinki) for drive systems have form-wound windings. All HXR machines manufactured in Helsinki starting 1.1.1998 have form-wound windings.

Note 5: *ABB motors of types other than M2_, M3_, HX_ and AM_*

Use the selection criteria given for non-ABB motors.

Note 6: *Resistor braking of the drive*

When the drive is in braking mode for a large part of its operation time, the intermediate circuit DC voltage of the drive increases, the effect being similar to increasing the supply voltage by up to 20 percent. The voltage increase should be taken into consideration when determining the motor insulation requirement.

Example: Motor insulation requirement for a 400 V application must be selected as if the drive were supplied with 480 V.

Note 7: Drives with an IGBT supply unit

If voltage is raised by the drive (this is a parameter selectable function), select the motor insulation system according to the increased intermediate circuit DC voltage level, especially in the 500 V supply voltage range.

Note 8: Calculating the rise time and the peak line-to-line voltage

The peak line-to-line voltage at the motor terminals generated by the drive as well as the voltage rise time depend on the cable length. The requirements for the motor insulation system given in the table are “worst case” requirements covering installations with 30 metre and longer cables. The rise time can be calculated as follows: $\Delta t = 0.8 \cdot \hat{U}_{LL}/(du/dt)$. Read \hat{U}_{LL} and du/dt from the diagrams below. Multiply the values of the graph by the supply voltage (U_N). In case of drives with an IGBT supply unit or resistor braking, the \hat{U}_{LL} and du/dt values are approximately 20 % higher.

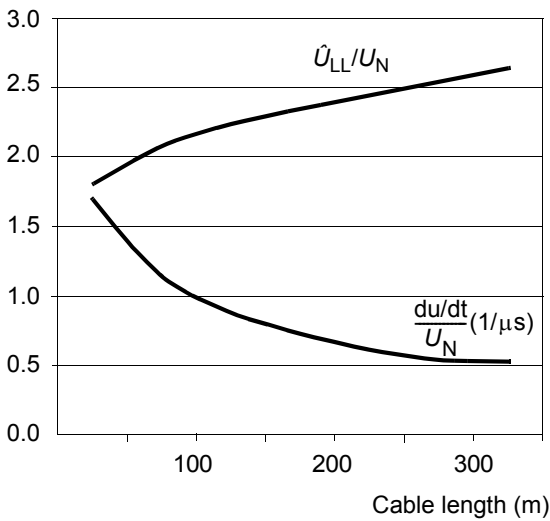

With du/dt Filter

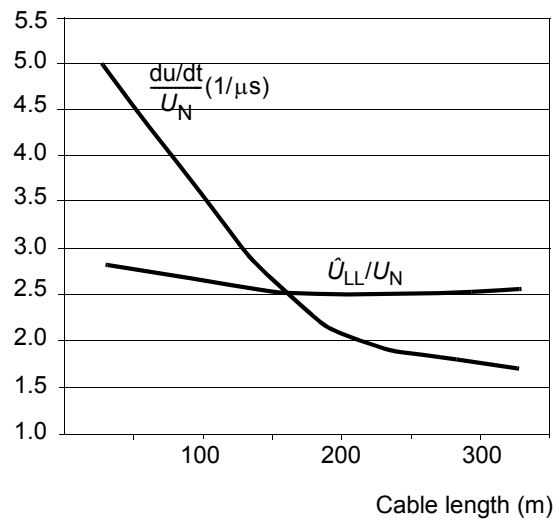

Without du/dt Filter

Note 9: Sine filters protect the motor insulation system. Therefore, du/dt filter can be replaced with a sine filter. The peak phase-to-phase voltage with the sine filter is approximately $1.5 \times U_N$.

Permanent magnet synchronous motor

Only one permanent magnet motor can be connected to the inverter output.

It is recommended to install a safety switch between the permanent magnet synchronous motor and the drive output. The switch is needed to isolate the motor during any maintenance work on the drive.

Supply connection

Disconnecting device (disconnecting means)

ACS800-01, ACS800-U1, ACS800-11, ACS800-U11, ACS800-31, ACS800-U31, ACS800-02 and ACS800-U2 without enclosure extension, ACS800-04, ACS800-U4

Install a hand-operated input disconnecting device (disconnecting means) between the AC power source and the drive. The disconnecting device must be of a type that can be locked to the open position for installation and maintenance work.

ACS800-02 and ACS800-U2 with enclosure extension, ACS800-07 and ACS800-U7

These units are equipped with a hand-operated input disconnecting device (disconnecting means) which isolates the drive and the motor from the AC power as standard. The disconnecting device does not, however, isolate the input busbars from the AC power. Therefore, during installation and maintenance work on the drive, the input cables and busbars must be isolated from the input power with a disconnecter at the distribution board or at the supplying transformer.

EU

To meet the European Union Directives, according to standard EN 60204-1, Safety of Machinery, the disconnecting device must be one of the following types:

- switch-disconnector of utilization category AC-23B (EN 60947-3)
- disconnector that has an auxiliary contact that in all cases causes switching devices to break the load circuit before the opening of the main contacts of the disconnector (EN 60947-3)
- circuit breaker suitable for isolation in accordance with EN 60947-2.

US

The disconnecting means must conform to the applicable safety regulations.

Fuses

See section [Thermal overload and short-circuit protection](#).

Thermal overload and short-circuit protection

Thermal overload protection

The drive protects itself and the input and motor cables against thermal overload when the cables are dimensioned according to the nominal current of the drive. No additional thermal protection devices are needed.



WARNING! If the drive is connected to multiple motors, a separate thermal overload switch or a circuit breaker must be used for protecting each cable and motor. These devices may require a separate fuse to cut off the short-circuit current.

The drive protects the motor cable and motor in a short-circuit situation when the motor cable is dimensioned according to the nominal current of the drive.

Short-circuit protection

Protect the input cable and drive against short-circuit according to the following guide lines.

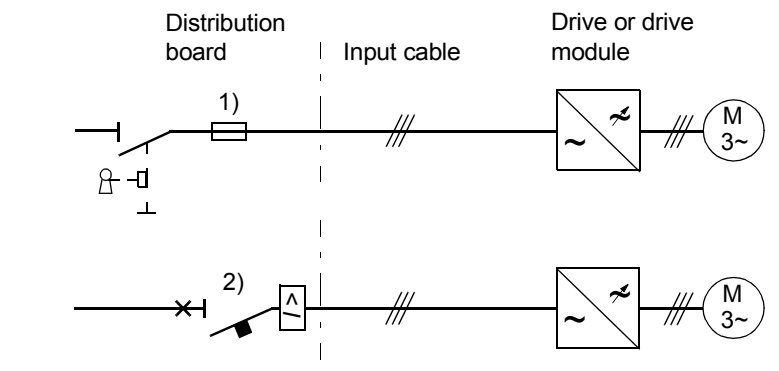
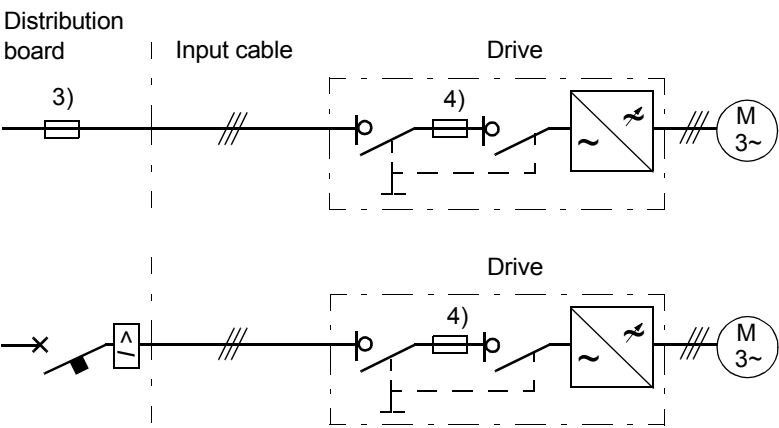
Circuit diagram	Drive type	Short-circuit protection
DRIVE IS NOT EQUIPPED WITH INPUT FUSES		
 <p>Distribution board Input cable Drive or drive module</p> <p>1)</p> <p>2)</p>	ACS800-01 ACS800-U1 ACS800-02 ACS800-U2+0C111 ACS800-11 ACS800-U11 ACS800-31 ACS800-U31 ACS800-04 ACS800-U4	Protect the drive and input cable with fuses or a circuit breaker. See footnotes 1) and 2).
DRIVE IS EQUIPPED WITH INPUT FUSES		
 <p>Distribution board Input cable Drive</p> <p>3)</p> <p>4)</p>	ACS800-02+C111 ACS800-U2 ACS800-07 ACS800-U7	Protect the input cable with fuses or a circuit breaker according to local regulations. See footnotes 3) and 4).

- 1) Size the fuses according to local safety regulations, appropriate input voltage and the rated current of the drive (see *Technical data*).

Standard gG fuses (US: CC or T for the ACS800-U1, ACS800-U11 and ACS800-U31; T or L for the ACS800-U2 and ACS800-U4) will protect the input cable in short-circuit situations, restrict drive damage and prevent damage to adjoining equipment in case of a short-circuit inside the drive.

Check that the operating time of the fuse is below 0.5 seconds (0.1 seconds with ACS800-11/U11, ACS800-31/U31). The operating time depends on the fuse type (gG or aR), supply network impedance and the cross-sectional area, material and length of the supply cable. In case the 0.5 seconds (0.1 seconds with ACS800-11/U11 and ACS800-31/U31) operating time is exceeded with gG fuses (US: CC/T/L), ultrarapid (aR) fuses will in most cases reduce the operating time to an acceptable level. The US fuses must be of the "non-time delay" type.

For fuse ratings, see *Technical data*.

- 2) Circuit breakers which have been tested by ABB with the ACS800 can be used. Fuses must be used with other circuit breakers. Contact your local ABB representative for approved breaker types and supply network characteristics.

The protective characteristics of circuit breakers depend on the type, construction and settings of the breakers. There are also limitations pertaining to the short-circuit capacity of the supply network.



WARNING! Due to the inherent operating principle and construction of circuit breakers, independent of the manufacturer, hot ionized gases may escape from the breaker enclosure in case of a short-circuit. To ensure safe use, special attention must be paid to the installation and placement of the breakers. Follow the manufacturer's instructions.

Note: Circuit breakers without fuses are not recommended in the USA.

- 3) Size the fuses according to local safety regulations, appropriate input voltage and the rated current of the drive (see *Technical data*).
- 4) ACS800-07/U7 units and ACS800-02/U2 units with enclosure extension are equipped with standard gG (US: T/L) or optional aR fuses listed in *Technical data*. The fuses restrict drive damage and prevent damage to adjoining equipment in case of a short-circuit inside the drive.

Check that the operating time of the fuse is below 0.5 seconds. The operating time depends on the fuse type (gG or aR), supply network impedance and the cross-sectional area, material and length of the supply cable. In case the 0.5 seconds operating time is exceeded with gG fuses (US: CC/T/L), ultrarapid (aR) fuses will in most cases reduce the operating time to an acceptable level. The US fuses must be of the "non-time delay" type.

For fuse ratings, see *Technical data*.

Ground fault protection

The drive is equipped with an internal ground fault protective function to protect the unit against ground faults in the motor and motor cable. This is not a personal safety or a fire protection feature. The ground fault protective function can be disabled with a parameter, refer to the appropriate *ACS800 Firmware Manual*.

The EMC filter of the drive includes capacitors connected between the main circuit and the frame. These capacitors and long motor cables increase the ground leakage current and may cause fault current circuit breakers to function.

Emergency stop devices

For safety reasons, install the emergency stop devices at each operator control station and at other operating stations where emergency stop may be needed.

Note: Pressing the stop key (⏏) on the control panel of the drive does not generate an emergency stop of the motor or separate the drive from dangerous potential.

ACS800-02/U2 with enclosure extension and ACS800-07/U7

An emergency stop function is optionally available for stopping and switching off the whole drive. Two stop categories according to IEC/EN 60204-1 (1997) are available: immediate removal of power (Category 0 for ACS800-02/U2 and ACS800-07/U7) and controlled emergency stop (Category 1 for ACS800-07/U7).

Restarting after an emergency stop

After an emergency stop, the emergency stop button must be released and the drive started by turning the operating switch of the drive from position "ON" to "START".

Prevention of Unexpected Start

The ACS800-04, ACS800-31/U31 and ACS800-07/U7 can be equipped with an optional Prevention of Unexpected Start function according to standards IEC/EN 60204-1: 1997; ISO/DIS 14118: 2000 and EN 1037: 1996.

The Prevention of Unexpected Start function disables the control voltage of the power semiconductors, thus preventing the inverter from generating the AC voltage required to rotate the motor. By using this function, short-time operations (like cleaning) and/or maintenance work on non-electrical parts of the machinery can be performed without switching off the AC power supply to the drive.

The operator activates the Prevention of Unexpected Start function by opening a switch on a control desk. An indicating lamp on the control desk will light, signalling that the prevention is active. The switch can be locked out.

The user must install on a control desk near the machinery:

- switching/disconnecting device for the circuitry. "Means shall be provided to prevent inadvertent, and/or mistaken closure of the disconnecting device." EN 60204-1: 1997.
- indicating lamp; on = starting the drive is prevented, off = drive is operative.

For connections to the drive, see the circuit diagram delivered with the drive.



WARNING! The Prevention of Unexpected Start function does not disconnect the voltage of the main and auxiliary circuits from the drive. Therefore maintenance work on electrical parts of the drive or the motor can only be carried out after isolating the drive system from the main supply.

Note: The Prevention of Unexpected Start function is not intended for stopping the drive. If a running drive is stopped by using the Prevention of Unexpected Start function, the drive will cut off the motor supply voltage and the motor will coast to stop.

Selecting the power cables

General rules

Dimension the mains (input power) and motor cables **according to local regulations**:

- The cable must be able to carry the drive load current. See chapter *Technical data* for the rated currents.
- The cable must be rated for at least 70 °C maximum permissible temperature of conductor in continuous use. For US, see [Additional US requirements](#).
- The inductance and impedance of the PE conductor/cable (grounding wire) must be rated according to permissible touch voltage appearing under fault conditions (so that the fault point voltage will not rise excessively when a ground fault occurs).
- 600 VAC cable is accepted for up to 500 VAC. 750 VAC cable is accepted for up to 600 VAC. For 690 VAC rated equipment, the rated voltage between the conductors of the cable should be at least 1 kV.

For drive frame size R5 and larger, or motors larger than 30 kW (40 HP), symmetrical shielded motor cable must be used (figure below). A four-conductor system can be used up to frame size R4 with up to 30 kW (40 HP) motors, but shielded symmetrical motor cable is recommended.

Note: When continuous conduit is employed, shielded cable is not required.

A four-conductor system is allowed for input cabling, but shielded symmetrical cable is recommended. To operate as a protective conductor, the shield conductivity must be as follows when the protective conductor is made of the same metal as the phase conductors:

Cross-sectional area of the phase conductors S (mm ²)	Minimum cross-sectional area of the corresponding protective conductor S_p (mm ²)
$S \leq 16$	S
$16 < S \leq 35$	16
$35 < S$	$S/2$

Compared to a four-conductor system, the use of symmetrical shielded cable reduces electromagnetic emission of the whole drive system as well as motor bearing currents and wear.

The motor cable and its PE pigtail (twisted shield) should be kept as short as possible in order to reduce electromagnetic emission.

Alternative power cable types

Power cable types that can be used with the drive are represented below.

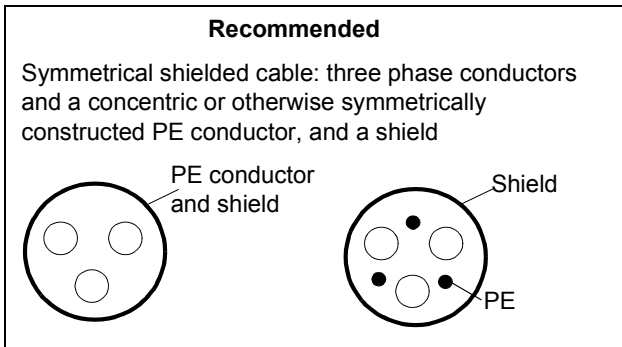

A separate PE conductor is required if the conductivity of the cable shield is < 50 % of the conductivity of the phase conductor.

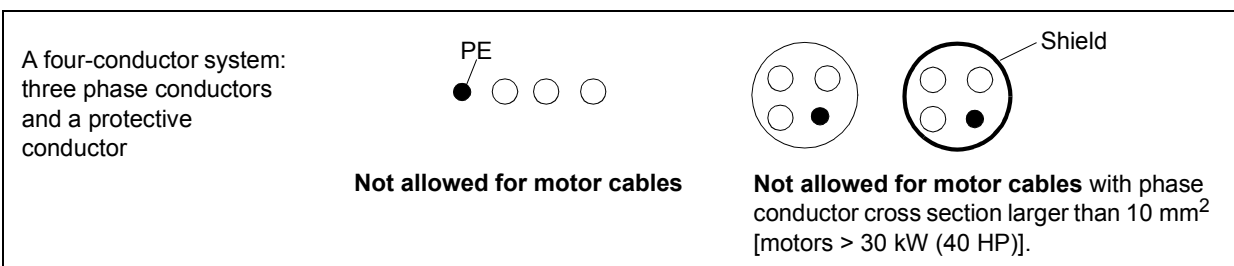
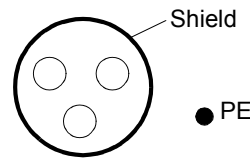

Motor cable shield

To effectively suppress radiated and conducted radio-frequency emissions, the shield conductivity must be at least 1/10 of the phase conductor conductivity. The requirements are easily met with a copper or aluminium shield. The minimum requirement of the motor cable shield of the drive is shown below. It consists of a concentric layer of copper wires with an open helix of copper tape. The better and tighter the shield, the lower the emission level and bearing currents.

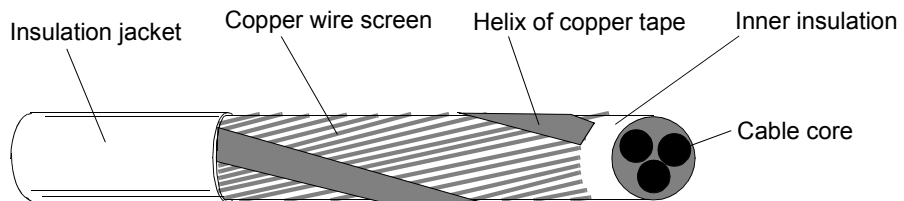

Additional US requirements

Type MC continuous corrugated aluminum armor cable with symmetrical grounds or shielded power cable must be used for the motor cables if metallic conduit is not used. For the North American market, 600 VAC cable is accepted for up to 500 VAC. 1000 VAC cable is required above 500 VAC (below 600 VAC). For drives rated over 100 amperes, the power cables must be rated for 75 °C (167 °F).

Conduit

Where conduits must be coupled together, bridge the joint with a ground conductor bonded to the conduit on each side of the joint. Bond the conduits also to the drive enclosure. Use separate conduits for input power, motor, brake resistor, and control wiring. When conduit is employed, type MC continuous corrugated aluminium armor cable or shielded cable is not required. A dedicated ground cable is always required.

Note: Do not run motor wiring from more than one drive in the same conduit.

Armored cable / shielded power cable

Six conductor (3 phases and 3 ground) type MC continuous corrugated aluminum armor cable with symmetrical grounds is available from the following suppliers (trade names in parentheses):

- Anixter Wire & Cable (Philsheath)
- BICC General Corp (Philsheath)
- Rockbestos Co. (Gardex)
- Oaknite (CLX).

Shielded power cables are available from Belden, LAPPKABEL (ÖLFLEX) and Pirelli.

Power factor compensation capacitors

Power factor compensation is not needed with AC drives. However, if a drive is to be connected in a system with compensation capacitors installed, note the following restrictions.



WARNING! Do not connect power factor compensation capacitors to the motor cables (between the drive and the motor). They are not meant to be used with AC drives and can cause permanent damage to the drive or themselves.

If there are power factor compensation capacitors in parallel with the three phase input of the drive:

1. Do not connect a high-power capacitor to the power line while the drive is connected. The connection will cause voltage transients that may trip or even damage the drive.
2. If capacitor load is increased/decreased step by step when the AC drive is connected to the power line: Ensure that the connection steps are low enough not to cause voltage transients that would trip the drive.
3. Check that the power factor compensation unit is suitable for use in systems with AC drives i.e. harmonic generating loads. In such systems, the compensation unit should typically be equipped with a blocking reactor or harmonic filter.

Equipment connected to the motor cable

Installation of safety switches, contactors, connection boxes, etc.

To minimize the emission level when safety switches, contactors, connection boxes or similar equipment are installed in the motor cable between the drive and the motor:

- EU: Install the equipment in a metal enclosure with 360 degrees grounding for the shields of both the incoming and outgoing cable, or connect the shields of the cables otherwise together.
- US: Install the equipment in a metal enclosure in a way that the conduit or motor cable shielding runs consistently without breaks from the drive to the motor.

Bypass connection



WARNING! Never connect the supply power to the drive output terminals U2, V2 and W2. If frequent bypassing is required, employ mechanically connected switches or contactors. Mains (line) voltage applied to the output can result in permanent damage to the unit.

Before opening a contactor (DTC control mode selected)

Stop the drive and wait for the motor to stop before opening a contactor between the output of the drive and the motor when the DTC control mode is selected. See the appropriate ACS800 application program firmware manual for the required parameter settings. Otherwise, the contactor will be damaged. In scalar control, the contactor can be opened with the drive running.

Protecting the relay output contacts and attenuating disturbances in case of inductive loads

Inductive loads (relays, contactors, motors) cause voltage transients when switched off.

The relay contacts on the RMIO board are protected with varistors (250 V) against overvoltage peaks. In spite of this, it is highly recommended to equip inductive loads with noise attenuating circuits [varistors, RC filters (AC) or diodes (DC)] in order to minimize the EMC emission at switch-off. If not suppressed, the disturbances may connect capacitively or inductively to other conductors in the control cable and form a risk of malfunction in other parts of the system.

Install the protective component as close to the inductive load as possible. Do not install protective components at the RMIO board terminal block.

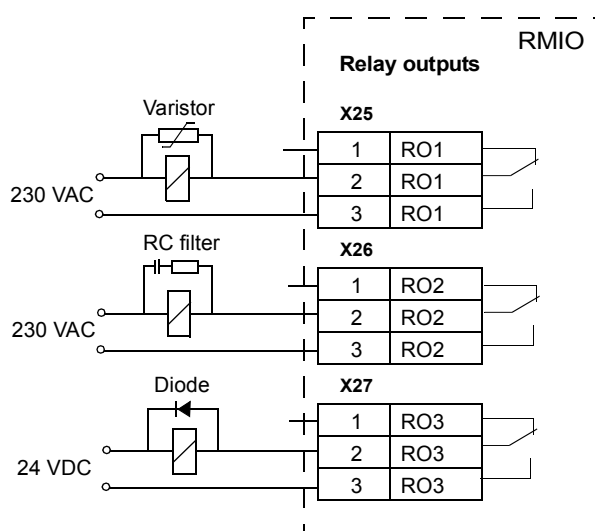

Selecting the control cables

All control cables must be shielded.

Use a double-shielded twisted pair cable (Figure a, e.g. JAMAK by NK Cables, Finland) for analogue signals. This type of cable is recommended for the pulse encoder signals also. Employ one individually shielded pair for each signal. Do not use common return for different analogue signals.

A double-shielded cable is the best alternative for low-voltage digital signals but single-shielded twisted pair cable (Figure b) is also usable.

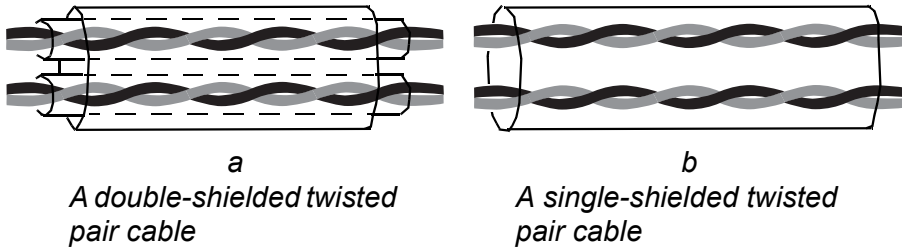

Run analogue and digital signals in separate, shielded cables.

Relay-controlled signals, providing their voltage does not exceed 48 V, can be run in the same cables as digital input signals. It is recommended that the relay-controlled signals be run as twisted pairs.

Never mix 24 VDC and 115/230 VAC signals in the same cable.

Relay cable

The cable type with braided metallic screen (e.g. ÖLFLEX by LAPPKABEL, Germany) has been tested and approved by ABB.

Control panel cable

In remote use, the cable connecting the control panel to the drive must not exceed 3 metres (10 ft). The cable type tested and approved by ABB is used in control panel option kits.

Connection of a motor temperature sensor to the drive I/O



WARNING! IEC 60664 requires double or reinforced insulation between live parts and the surface of accessible parts of electrical equipment which are either non-conductive or conductive but not connected to the protective earth.

To fulfil this requirement, the connection of a thermistor (and other similar components) to the digital inputs of the drive can be implemented in three alternate ways:

1. There is double or reinforced insulation between the thermistor and live parts of the motor.
 2. Circuits connected to all digital and analogue inputs of the drive are protected against contact and insulated with basic insulation (the same voltage level as the drive main circuit) from other low voltage circuits.
 3. An external thermistor relay is used. The insulation of the relay must be rated for the same voltage level as the main circuit of the drive. For connection, see *ACS800 Firmware Manual*.
-

Installation sites above 2000 metres (6562 feet)



WARNING! Protect against direct contact when installing, operating and servicing the RMIO board wiring and optional modules attached to the board. The Protective Extra Low Voltage (PELV) requirements stated in EN 50178 are not fulfilled at altitudes above 2000 m (6562 ft).

Routing the cables

Route the motor cable away from other cable routes. Motor cables of several drives can be run in parallel installed next to each other. It is recommended that the motor cable, input power cable and control cables be installed on separate trays. Avoid long parallel runs of motor cables with other cables in order to decrease electromagnetic interference caused by the rapid changes in the drive output voltage.

Where control cables must cross power cables make sure they are arranged at an angle as near to 90 degrees as possible. Do not run extra cables through the drive.

The cable trays must have good electrical bonding to each other and to the grounding electrodes. Aluminium tray systems can be used to improve local equalizing of potential.

A diagram of the cable routing is shown below.

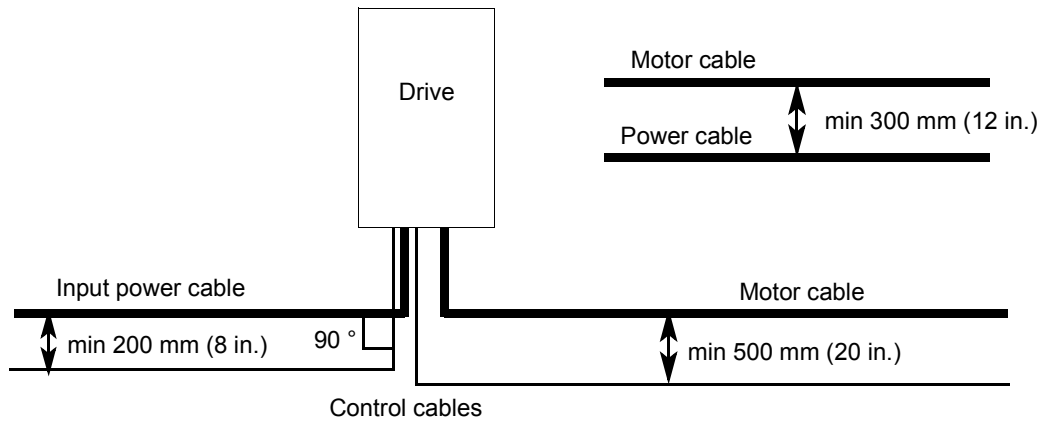

Control cable ducts

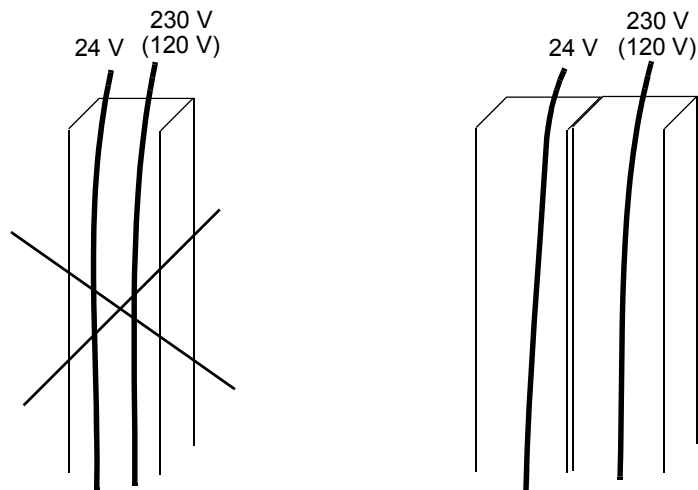

Not allowed unless the 24 V cable is insulated for 230 V (120 V) or insulated with an insulation sleeving for 230 V (120 V).

Lead 24 V and 230 V (120 V) control cables in separate ducts inside the cabinet.

Electrical installation

What this chapter contains

This chapter describes the electrical installation procedure of the drive.



WARNING! The work described in this chapter may only be carried out by a qualified electrician. Follow the [Safety instructions](#) on the first pages of this manual. Ignoring the safety instructions can cause injury or death.

Make sure that the drive is disconnected from the mains (input power) during installation. If the drive is already connected to the mains, wait for 5 min after disconnecting mains power.

Checking the insulation of the assembly

Drive

Every drive has been tested for insulation between the main circuit and the chassis (2500 V rms 50 Hz for 1 second) at the factory. Therefore, do not make any voltage tolerance or insulation resistance tests (e.g. hi-pot or megger) on any part of the drive.

Input cable

Check the insulation of the input cable according to local regulations before connecting it to the drive.

Motor and motor cable

1. Check that the motor cable is disconnected from the drive output terminals U2, V2 and W2.
2. Measure the insulation resistances of the motor cable and the motor between each phase and the Protective Earth by using a measuring voltage of 1 kV DC. The insulation resistance must be higher than 1 Mohm.

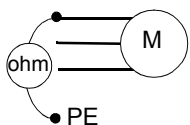

IT (ungrounded) systems

Disconnect the EMC filter capacitors of selections +E202 and +E200 before connecting the drive to an ungrounded system. For detailed instructions on how to do this, please contact your local ABB distributor.



WARNING! If a drive with EMC filter selection +E202 or +E200 is installed on an IT system [an ungrounded power system or a high resistance-grounded (over 30 ohms) power system], the system will be connected to earth potential through the EMC filter capacitors of the drive. This may cause danger or damage the unit.

Connecting the power cables

Diagram

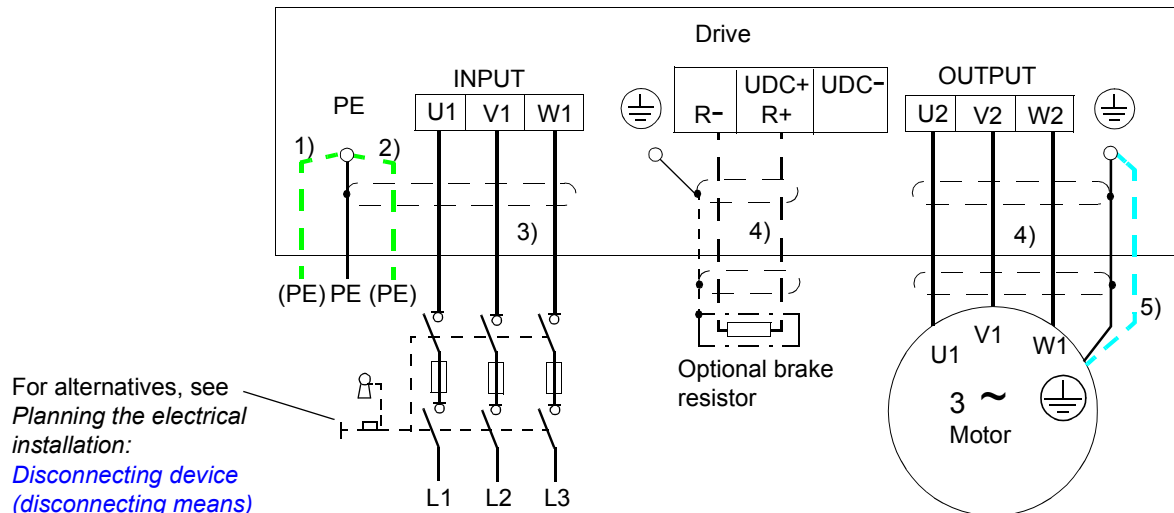

1), 2)

If shielded cable is used (not required but recommended), use a separate PE cable (1) or a cable with a grounding conductor (2) if the conductivity of the input cable shield is < 50 % of the conductivity of the phase conductor.

Ground the other end of the input cable shield or PE conductor at the distribution board.

3) 360 degrees grounding recommended if shielded cable

4) 360 degrees grounding required

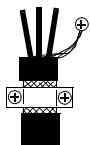

5) Use a separate grounding cable if the conductivity of the cable shield is < 50 % of the conductivity of the phase conductor and there is no symmetrically constructed grounding conductor in the cable (see *Planning the electrical installation / Selecting the power cables*).

Note:

If there is a symmetrically constructed grounding conductor in the motor cable in addition to the conductive shield, connect the grounding conductor to the grounding terminal at the drive and motor ends.

Do not use an asymmetrically constructed motor cable for motors > 30 kW (40 HP). Connecting its fourth conductor at the motor end increases bearing currents and causes extra wear.

Grounding of the motor cable shield at the motor end

For minimum radio frequency interference:

- ground the cable shield 360 degrees at the lead-through of the motor terminal box

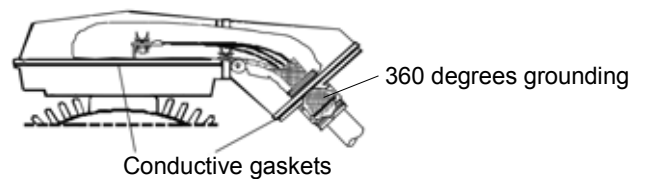

- or ground the cable by twisting the shield as follows: flattened width $\geq 1/5 \cdot \text{length}$.

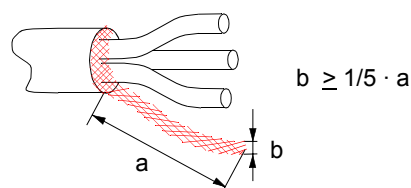

Conductor stripping lengths

Strip the conductor ends as follows to fit them inside the power cable connection terminals.

Frame size	Stripping length	
	mm	in.
R2, R3	10	0.39
R4, R5	16	0.63
R6	28	1.10

Allowed wire sizes, tightening torques

See [Technical data: Cable entries](#).

Wall installed units (European version)

Power cable installation procedure

1. Remove the front cover (in frame size R6 the lower front cover) by releasing the retaining clip with a screw driver and lifting the cover from the bottom outwards. For IP 55 units, see *Mechanical installation* / [Mounting the drive on the wall](#).
2. Slide the back plate of the connection box to the holes below the drive.
3. Fasten the back plate to the drive frame with two screws / three screws in frame size R6.
4. Cut adequate holes into the rubber grommets and slide the grommets onto the cables. Slide the cables through the holes of the bottom plate.
5. Strip off the plastic sheath of the cable under the 360 degrees grounding clamp. Fasten the clamp onto the stripped part of the cable.
6. Connect the twisted shield of the cable to the grounding terminal. **Note:** cable lugs are needed in frame sizes R2 and R3.
7. Connect the phase conductors of the mains cable to the U1, V1 and W1 terminals and the phase conductors of the motor cable to the U2, V2 and W2 terminals.
8. Fasten the bottom plate of the connection box with two screws to the already fastened back plate and slide the grommets into their place.
9. Secure the cables outside the unit mechanically. Connect the control cables as described in section [Connecting the control cables](#). Fasten the covers (see [Fastening the control cables and covers](#)).

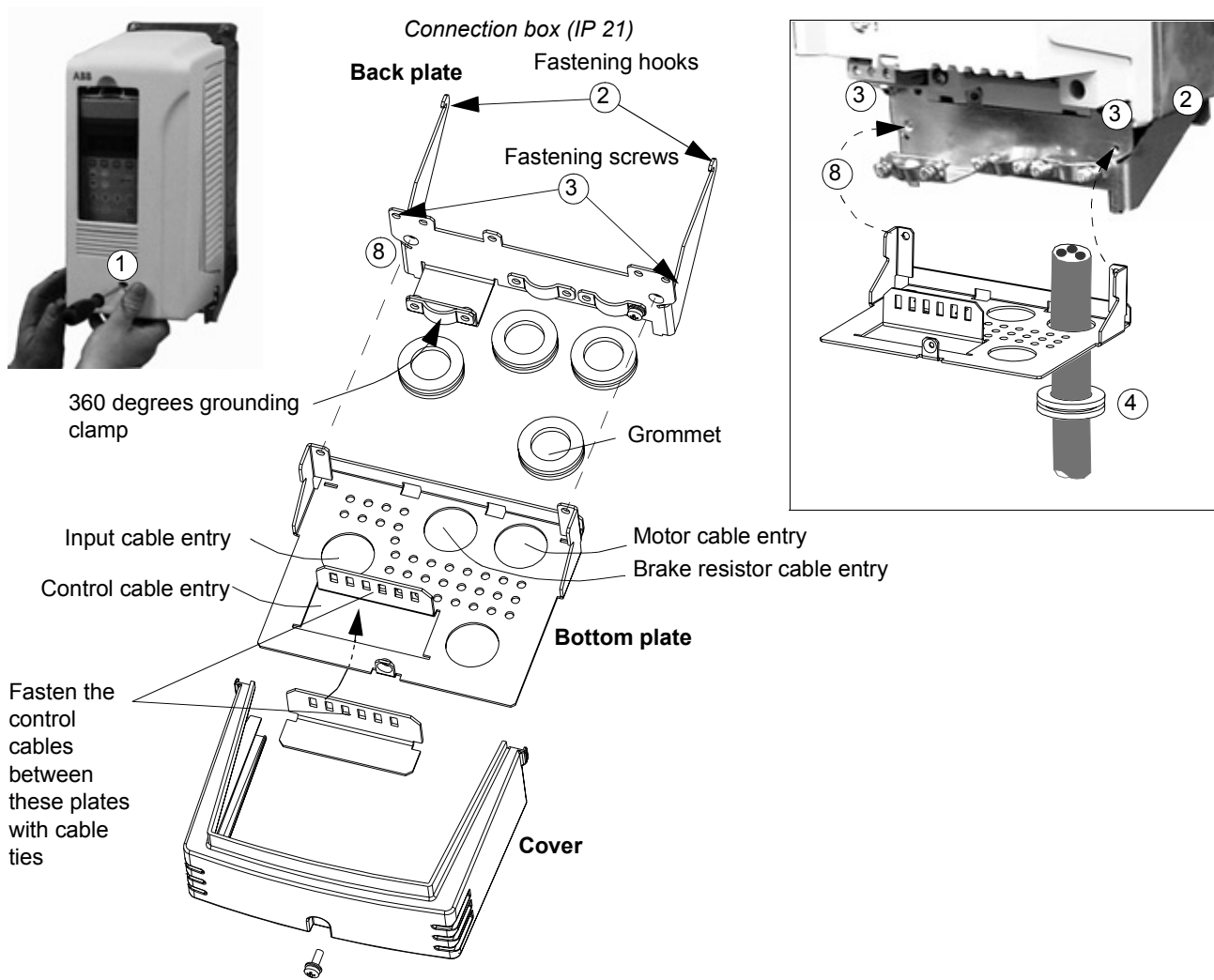

Frame sizes R2 to R4

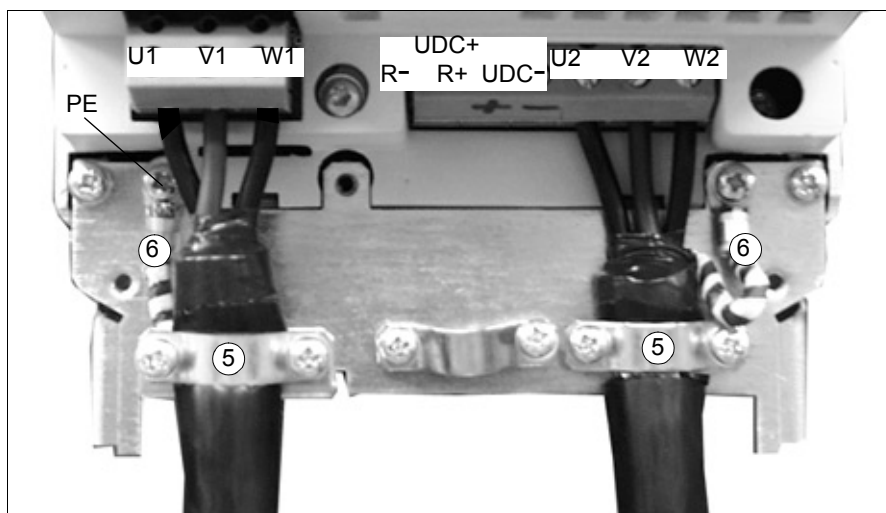

Input power cable

Motor cable

Frame size R5

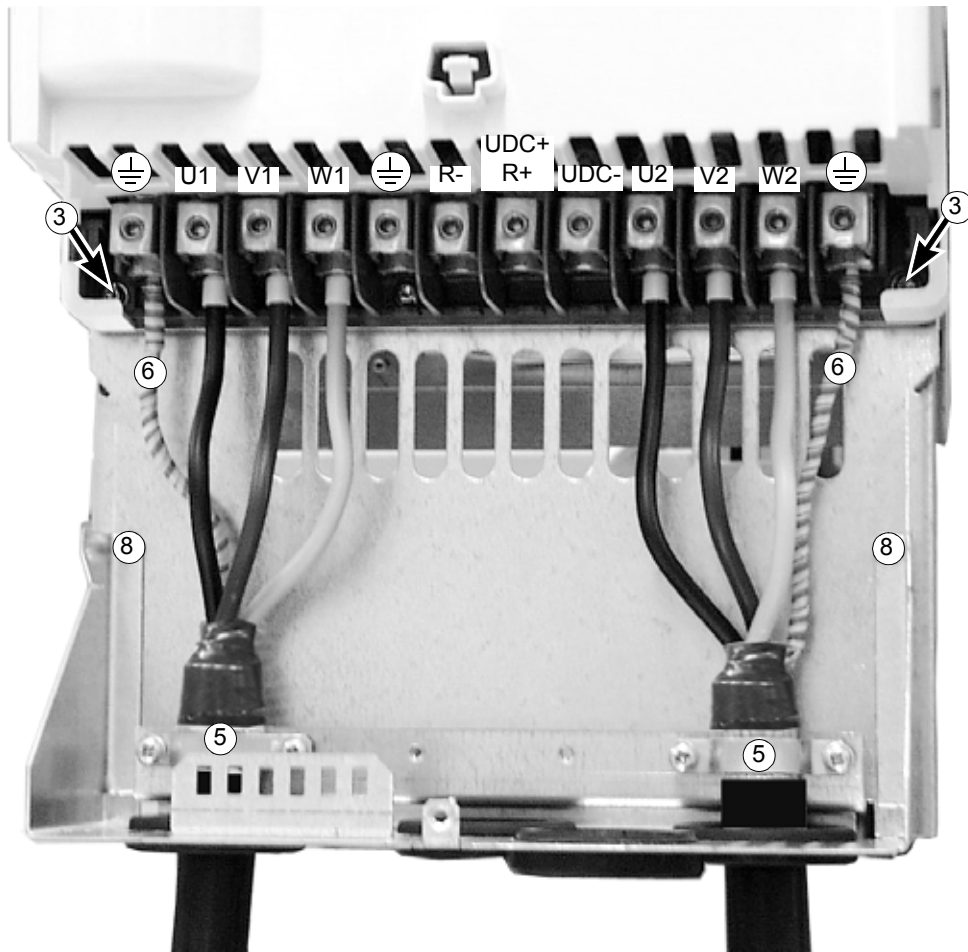

Frame size R6: Cable lug installation [16 to 70 mm² (6 to 2/0 AWG) cables]

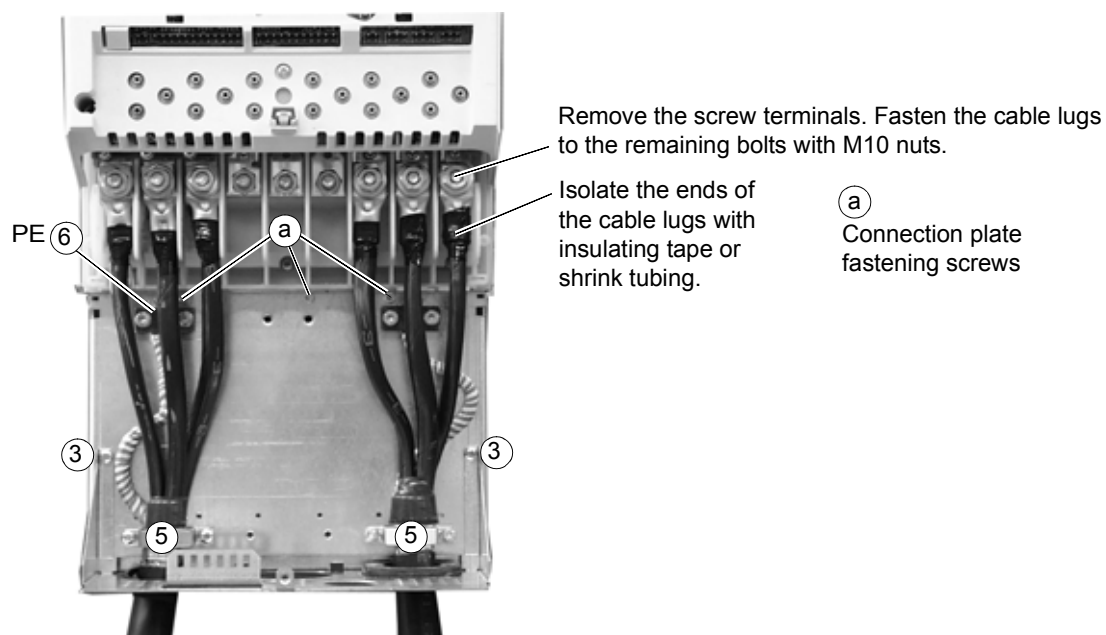

Frame size R6: Cable terminal installation [95 to 185 mm² (3/0 to 350 AWG) cables]

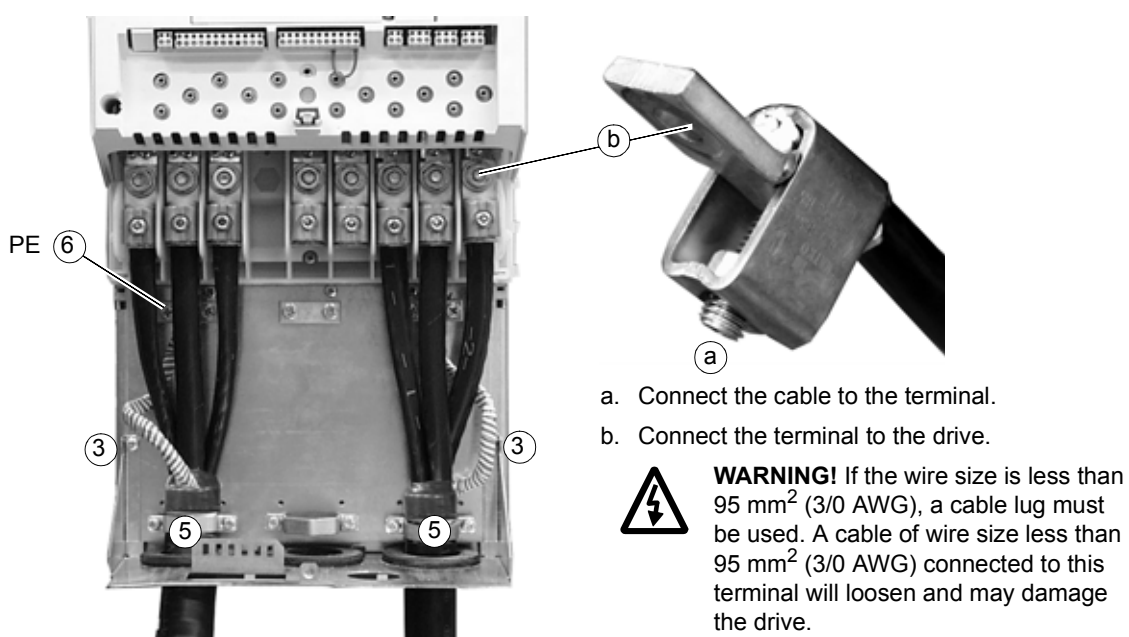

Wall installed units (US version)

1. Remove the front cover (in frame size R6 the lower front cover) by releasing the retaining clip with a screw driver and lifting the cover from the bottom outwards.
2. Make the cable entry holes in the gland box by breaking off the suitable knock-out plates with a screw driver.
3. Fasten the cable glands to the opened holes of the gland box.
4. Fasten the gland box to the frame with two screws / three screws in frame size R6.

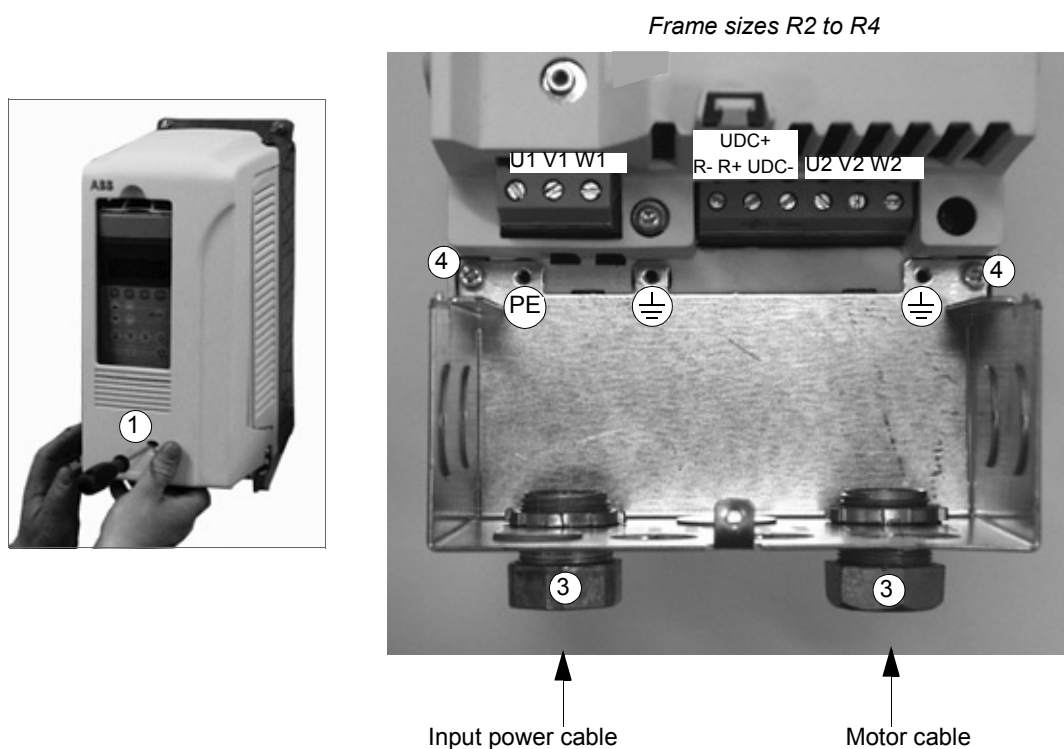

5. Lead the cables through the glands to the inside of the gland box.
6. Connect the PE conductors of the input and motor cables to the grounding terminal. **Note:** cable lugs are needed in frame sizes R2 and R3. Connect the separate PE conductor (if used) to the grounding terminal.
7. Connect the phase conductors of the input cable to the U1, V1 and W1 terminals and the phase conductors of the motor cable to the U2, V2 and W2 terminals.

For frame size R6, see [Wall installed units \(European version\)](#) / figures for frame size R6. In case of a cable lug installation, use UL listed cable lugs and tools given below or corresponding to meet UL requirements.

Wire size kcmil/AWG	Compression lug		Crimping tool		
	Manufacturer	Type	Manufacturer	Type	No. of crimps
6	Burndy	YAV6C-L2	Burndy	MY29-3	1
	IlSCO	CCL-6-38	IlSCO	ILC-10	2
4	Burndy	YA4C-L4BOX	Burndy	MY29-3	1
	IlSCO	CCL-4-38	IlSCO	MT-25	1
2	Burndy	YA2C-L4BOX	Burndy	MY29-3	2
	IlSCO	CRC-2	IlSCO	IDT-12	1
	IlSCO	CCL-2-38	IlSCO	MT-25	1
1	Burndy	YA1C-L4BOX	Burndy	MY29-3	2
	IlSCO	CRA-1-38	IlSCO	IDT-12	1
	IlSCO	CCL-1-38	IlSCO	MT-25	1
	Thomas & Betts	54148	Thomas & Betts	TBM-8	3
1/0	Burndy	YA25-L4BOX	Burndy	MY29-3	2
	IlSCO	CRB-0	IlSCO	IDT-12	1
	IlSCO	CCL-1/0-38	IlSCO	MT-25	1
	Thomas & Betts	54109	Thomas & Betts	TBM-8	3
2/0	Burndy	YAL26T38	Burndy	MY29-3	2
	IlSCO	CRA-2/0	IlSCO	IDT-12	1
	IlSCO	CCL-2/0-38	IlSCO	MT-25	1
	Thomas & Betts	54110	Thomas & Betts	TBM-8	3

8. Tighten the clamping nuts of the cable glands.

After connecting the control cables, fasten the front covers.

Warning sticker



There are warning stickers in different languages inside the packing box of the drive. Attach a warning sticker in the language of your choice onto the plastic skeleton above the power cable terminals.

Cabinet installation (IP 21, UL type 1)

The drive can be installed in a cabinet without the connection box and front cover.

It is recommended:

- to ground the cable shield 360 degrees at the cabinet entry
- to lead the cable unstripped as close to the terminals as possible.

Secure the cables mechanically.

Protect the RMIO board terminals X25 to X27 against contact when input voltage exceeds 50 VAC.

Frame size R5

Cover the power cable terminals as follows:

1. Cut holes for the installed cables into the clear plastic shroud.
2. Press the shroud onto the terminals.

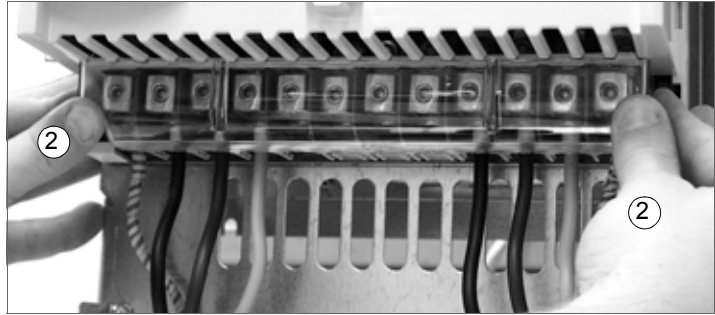
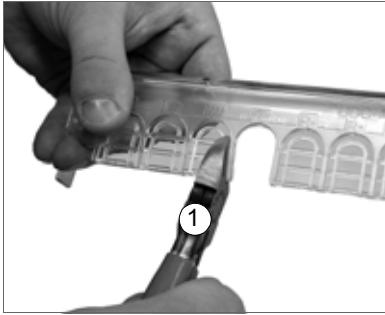

Removal of the shroud with a screw driver:

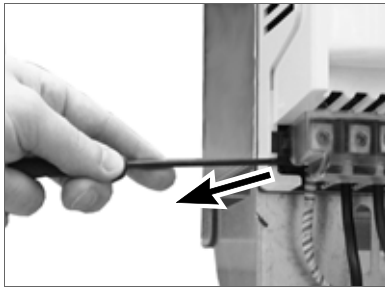

Frame size R6

Cover the power cable terminals as follows:

1. Cut holes for the installed cables into the clear plastic shroud in cable lug installations.
2. Press the shroud onto the terminals.

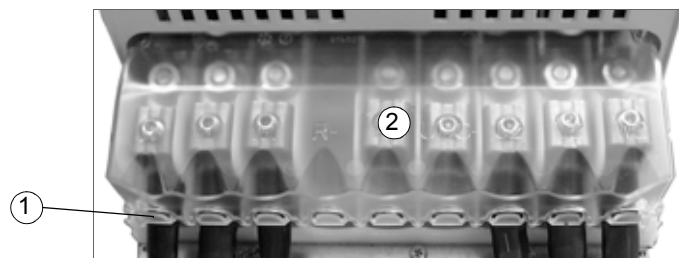

View of cable terminal installation

Removal of the shroud by lifting up with a screw driver from the corner:



Connecting the control cables

Lead the cable through the control cable entry (1).

Connect the control cables as described below. Connect the conductors to the appropriate detachable terminals of the RMIO board [refer to chapter *Motor control and I/O board (RMIO)*]. Tighten the screws to secure the connection.

Terminals

Frame sizes R2 to R4

The control cable connection terminals are exposed when the control panel mounting platform is turned aside by pulling this knob. **Be careful, do not use excess force when pulling.**

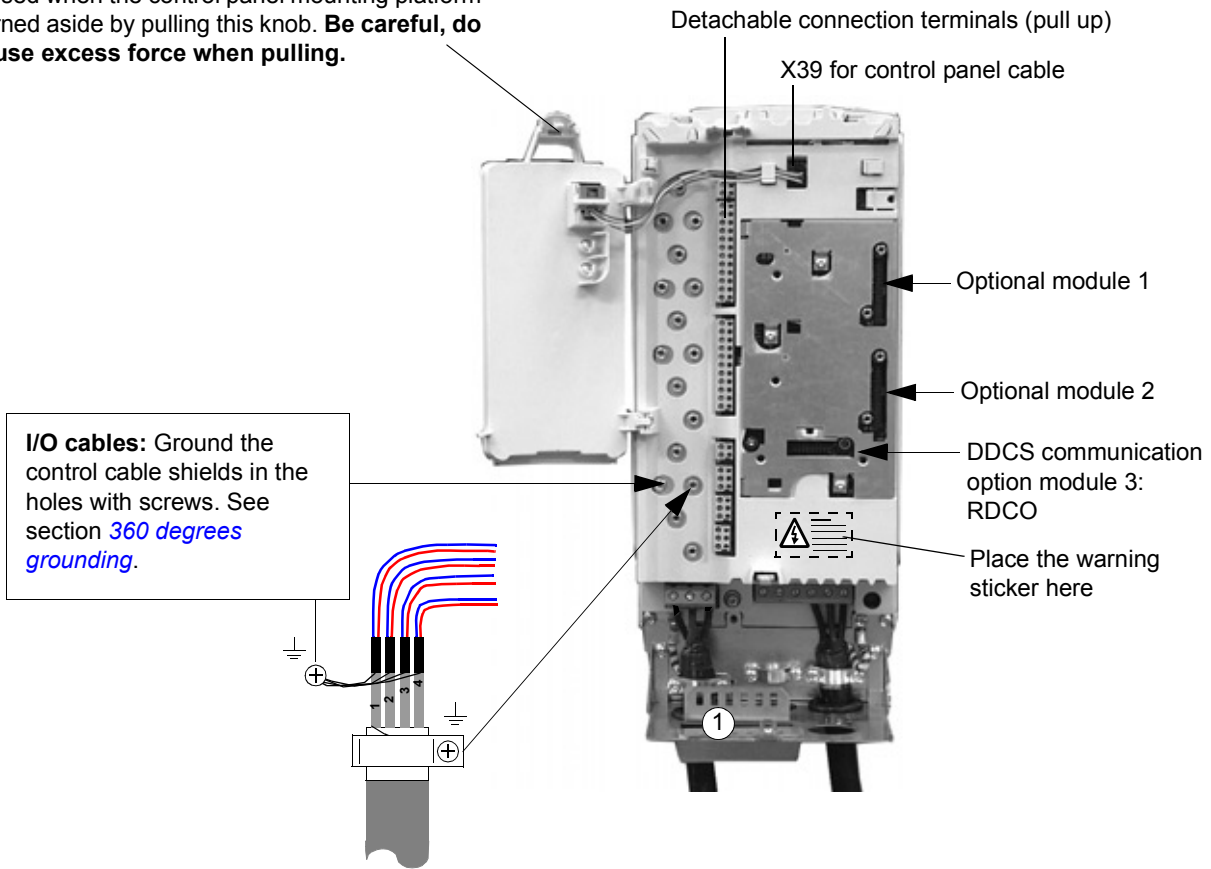

Frame sizes R5 and R6

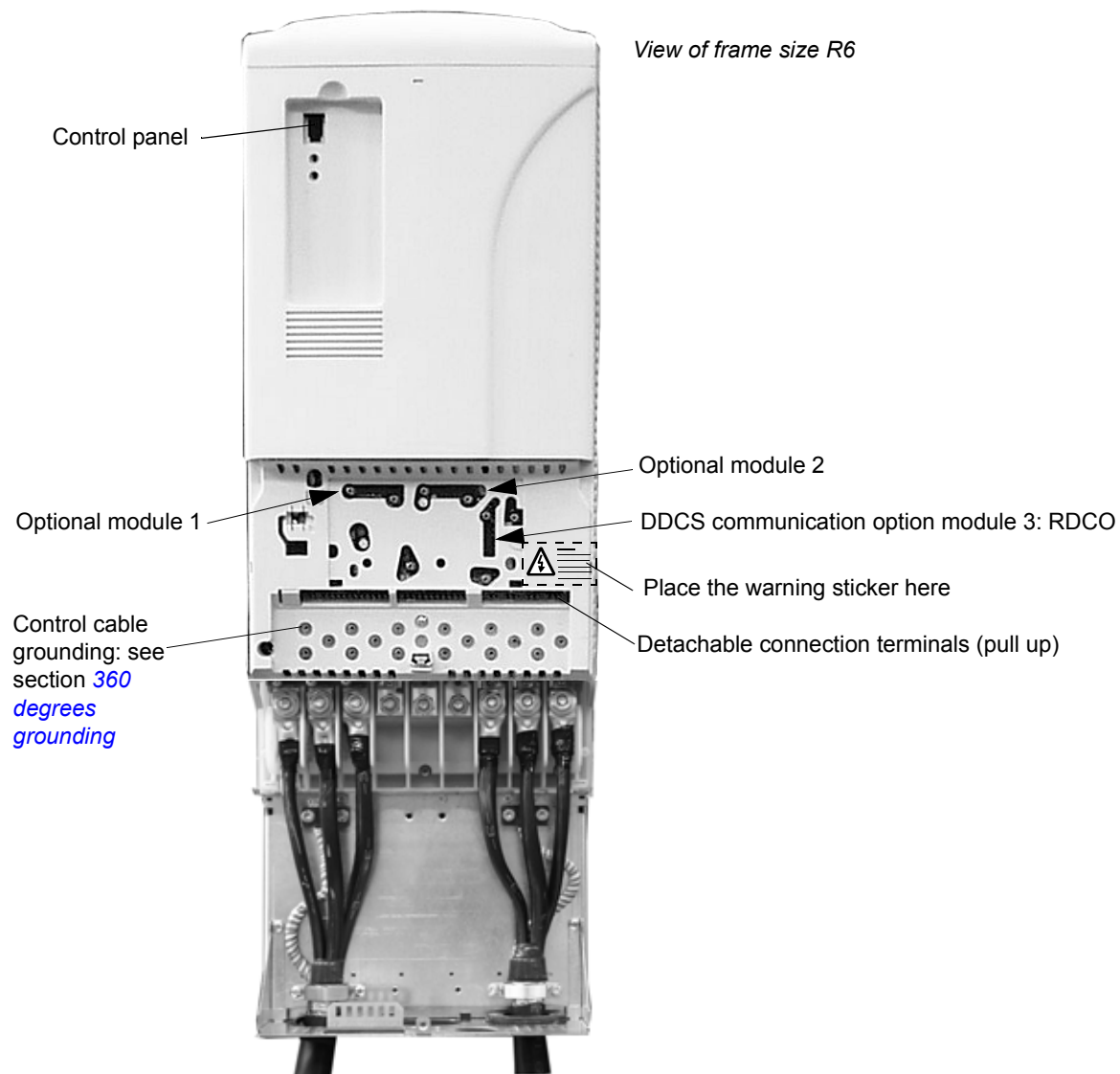

360 degrees grounding

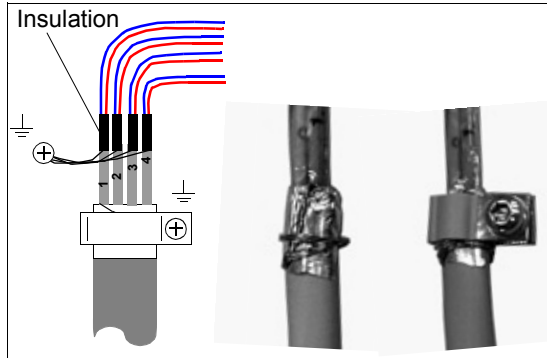

Double-shielded cable

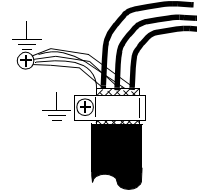

Single-shielded cable

When the outer surface of the shield is covered with non-conductive material

- Strip the cable carefully (do not cut the grounding wire and the shield)
- Turn the shield inside out to expose the conductive surface.
- Wrap the grounding wire around the conductive surface.
- Slide a conductive clamp onto the conductive part.
- Fasten the clamp to the grounding plate with a screw as close as possible to the terminals where the wires are about to be connected.

Connecting the shield wires

Single-shielded cables: Twist the grounding wires of the outer shield and connect them through the shortest possible route to the nearest grounding hole with a cable lug and a screw. Double-shielded cables: Connect each pair cable shield (twisted grounding wires) with other pair cable shields of the same cable to the nearest grounding hole with a cable lug and a screw.

Do not connect shields of different cables to the same cable lug and grounding screw.

Leave the other end of the shield unconnected or ground it indirectly via a few nanofarads high-frequency capacitor (e.g. 3.3 nF / 630 V). The shield can also be grounded directly at both ends if they are *in the same ground line* with no significant voltage drop between the end points.

Keep the signal wire pairs twisted as close to the terminals as possible. Twisting the wire with its return wire reduces disturbances caused by inductive coupling.

Cabling of I/O and fieldbus modules

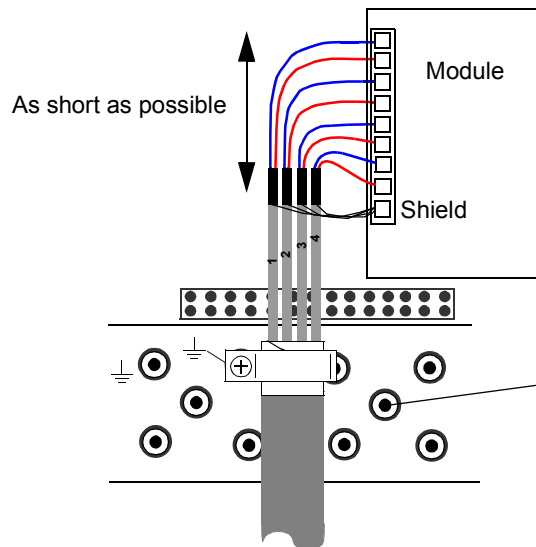

Note: The RDIO module does not include a terminal for cable shield grounding. Ground the pair cable shields here.

Pulse encoder module cabling

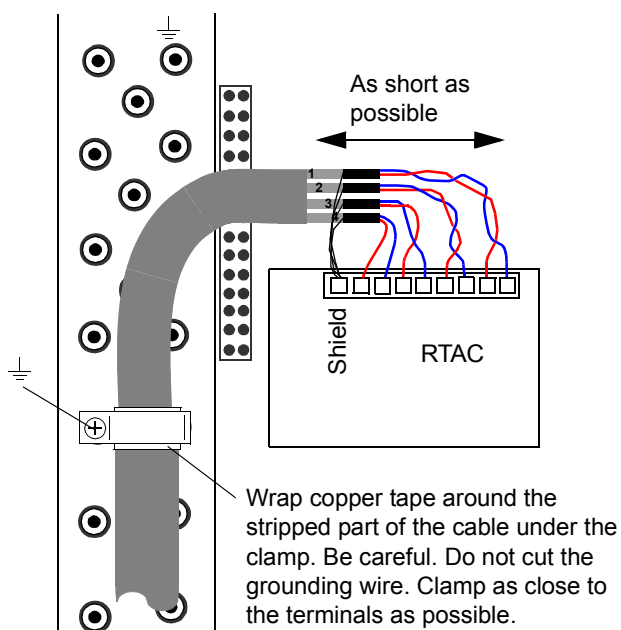

Note1: If the encoder is of unisolated type, ground the encoder cable at the drive end only. If the encoder is galvanically isolated from the motor shaft and the stator frame, ground the encoder cable shield at the drive and the encoder end.

Note 2: Twist the pair cable wires.

Fastening the control cables and covers

When all control cables are connected, fasten them together with cable ties. Units with a connection box: fasten the cables to the entry plate with cable ties. Units with a gland box: tighten the clamping nuts of the cable glands.

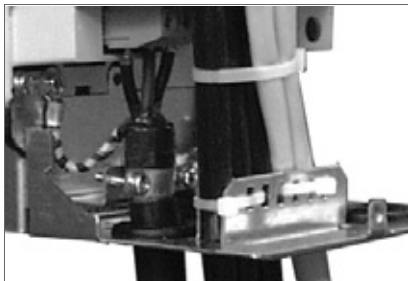

Fasten the connection box cover.



Replace the front cover.

Installation of optional modules and PC

The optional module (such as fieldbus adapter, I/O extension module and the pulse encoder interface) is inserted in the optional module slot of the RMIO board (see [Connecting the control cables](#)) and fixed with two screws. See the appropriate optional module manual for cable connections.

Fibre optic link

A DDCS fibre optic link is provided via the RDCO optional module for PC tools, master/follower link, NDIO, NTAC, NAI0 and fieldbus adapter modules of type Nxxx. See *RDCO User's Manual* for the connections. Observe colouring codes when installing fibre optic cables. Blue connectors go to blue terminals, and grey connectors to grey terminals.

When installing multiple modules on the same channel connect them in a ring.

Motor control and I/O board (RMIO)

What this chapter contains

This chapter shows

- external control connections to the RMIO board for the ACS800 Standard Application Program (Factory Macro)
- specifications of the inputs and outputs of the board.

To which products this chapter applies

This chapter applies to ACS800 units which employ RMIO-01 board from revision J onwards and RMIO-02 board from revision H onwards.

Note for the ACS800-02 with enclosure extension and the ACS800-07

The connections for the RMIO board shown below apply also to optional terminal block X2 available for the ACS800-02 and ACS800-07. The terminals of the RMIO board are wired to terminal block X2 internally.

Terminals of X2 accept cables from 0.5 to 4.0 mm² (22 to 12 AWG). Tightening torque for screw terminals is 0.4 to 0.8 Nm (0.3 to 0.6 lbf ft). For disconnecting wires from spring terminals, use a screw driver with a blade thickness of 0.6 mm (0.024 in.) and width of 3.5 mm (0.138 in.), e.g. PHOENIX CONTACT SZF 1-0,6X3,5.

Note on terminal labelling

Optional modules (Rxxx) may have identical terminal designations with the RMIO board.

Note on external power supply

External +24 V power supply for the RMIO board is recommended if

- the application requires a fast start after connecting the input power supply
- fieldbus communication is required when the input power supply is disconnected.

The RMIO board can be supplied from an external power source via terminal X23 or X34 or via both X23 and X34. The internal power supply to terminal X34 can be left connected when using terminal X23.



WARNING! If the RMIO board is supplied from an external power source via terminal X34, the loose end of the cable removed from the RMIO board terminal must be secured mechanically to a location where it cannot come into contact with electrical parts. If the screw terminal plug of the cable is removed, the wire ends must be individually insulated.

Parameter settings

In Standard Application Program, set parameter 16.9 CTRL BOARD SUPPLY to EXTERNAL 24V if the RMIO board is powered from an external supply.

External control connections (non-US)

External control cable connections to the RMIO board for the ACS800 Standard Application Program (Factory Macro) are shown below. For external control connections of other application macros and programs, see the appropriate *Firmware Manual*.

RMIO

Terminal block size:

cables 0.3 to 3.3 mm² (22 to 12 AWG)

Tightening torque:

0.2 to 0.4 Nm
(0.2 to 0.3 lbf ft)

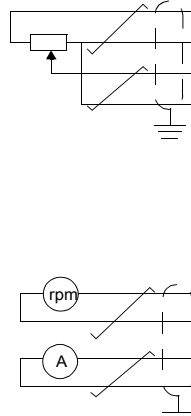

* optional terminal block in ACS800-02 and ACS800-07

1) Only effective if par. 10.03 is set to REQUEST by the user.

2) 0 = open, 1 = closed

DI4	Ramp times according to
0	parameters 22.02 and 22.03
1	parameters 22.04 and 22.05

3) See par. group 12 CONSTANT SPEEDS.

DI5	DI6	Operation
0	0	Set speed through AI1
1	0	Constant speed 1
0	1	Constant speed 2
1	1	Constant speed 3

4) See parameter 21.09 START INTRL FUNC.

5) Total maximum current shared between this output and optional modules installed on the board.

X2*	RMIO		
X20	X20	1	VREF- Reference voltage -10 VDC, 1 kohm ≤ R _L ≤ 10 kohm
		2	AGND
X21	X21	1	VREF+ Reference voltage 10 VDC, 1 kohm ≤ R _L ≤ 10 kohm
		2	AGND
		3	AI1+ Speed reference 0(2) ... 10 V, R _{in} > 200 kohm
		4	AI1-
		5	AI2+ By default, not in use. 0(4) ... 20 mA, R _{in} = 100 ohm
		6	AI2-
		7	AI3+ By default, not in use. 0(4) ... 20 mA, R _{in} = 100 ohm
		8	AI3-
		9	AO1+ Motor speed 0(4)...20 mA ≅ 0...motor nom. speed, R _L ≤ 700 ohm
		10	AO1-
		11	AO2+ Output current 0(4)...20 mA ≅ 0...motor nom. current, R _L ≤ 700 ohm
		12	AO2-
X22	X22	1	DI1 Stop/Start
		2	DI2 Forward/Reverse ¹⁾
		3	DI3 Not in use
		4	DI4 Acceleration & deceleration select ²⁾
		5	DI5 Constant speed select ³⁾
		6	DI6 Constant speed select ³⁾
		7	+24VD +24 VDC max. 100 mA
		8	+24VD
		9	DGND1 Digital ground
		10	DGND2 Digital ground
		11	DIIL Start interlock (0 = stop) ⁴⁾
X23	X23	1	+24V Auxiliary voltage output and input, non-isolated, 24 VDC 250 mA ⁵⁾
		2	GND
X25	X25	1	RO1 Relay output 1: ready
		2	RO1
		3	RO1
X26	X26	1	RO2 Relay output 2: running
		2	RO2
		3	RO2
X27	X27	1	RO3 Relay output 3: fault (-1)
		2	RO3
		3	RO3

External control connections (US)

External control cable connections to the RMIO board for the ACS800 Standard Application Program (Factory Macro US version) are shown below. For external control connections of other application macros and programs, see the appropriate *Firmware Manual*.

RMIO

Terminal block size:

cables 0.3 to 3.3 mm² (22 to 12 AWG)

Tightening torque:

0.2 to 0.4 Nm (0.2 to 0.3 lbf ft)

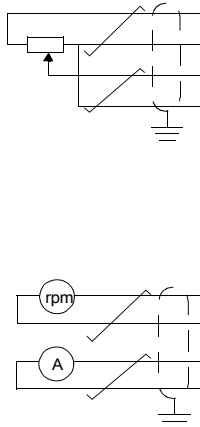

X2*	RMIO		
X20	X20	1	VREF-
		2	AGND
X21	X21	1	VREF+
		2	AGND
		3	AI1+
		4	AI1-
		5	AI2+
		6	AI2-
		7	AI3+
		8	AI3-
		9	AO1+
		10	AO1-
		11	AO2+
		12	AO2-
X22	X22	1	DI1
		2	DI2
		3	DI3
		4	DI4
		5	DI5
		6	DI6
		7	+24VD
		8	+24VD
		9	DGND1
		10	DGND2
		11	DIIL
X23	X23	1	+24V
		2	GND
X25	X25	1	RO1
		2	RO1
		3	RO1
X26	X26	1	RO2
		2	RO2
		3	RO2
X27	X27	1	RO3
		2	RO3
		3	RO3

* optional terminal block in ACS800-U2 and ACS800-U7

1) Only effective if par. 10.03 is set to REQUEST by the user.

2) 0 = open, 1 = closed

DI4	Ramp times according to
0	parameters 22.02 and 22.03
1	parameters 22.04 and 22.05

3) See par. group 12 CONSTANT SPEEDS.

DI5	DI6	Operation
0	0	Set speed through AI1
1	0	Constant speed 1
0	1	Constant speed 2
1	1	Constant speed 3

4) See parameter 21.09 START INTRL FUNC.

5) Total maximum current shared between this output and optional modules installed on the board.

RMIO board specifications

Analogue inputs

	With Standard Application Program two programmable differential current inputs (0 mA / 4 mA ... 20 mA, $R_{in} = 100 \text{ ohm}$) and one programmable differential voltage input (-10 V / 0 V / 2 V ... +10 V, $R_{in} > 200 \text{ kohm}$).
	The analogue inputs are galvanically isolated as a group.
Isolation test voltage	500 VAC, 1 min
Max. common mode voltage between the channels	$\pm 15 \text{ VDC}$
Common mode rejection ratio	$\geq 60 \text{ dB}$ at 50 Hz
Resolution	0.025 % (12 bit) for the -10 V ... +10 V input. 0.5 % (11 bit) for the 0 ... +10 V and 0 ... 20 mA inputs.
Inaccuracy	$\pm 0.5 \%$ (Full Scale Range) at 25 °C (77 °F). Temperature coefficient: $\pm 100 \text{ ppm}/^{\circ}\text{C}$ ($\pm 56 \text{ ppm}/^{\circ}\text{F}$), max.

Constant voltage output

Voltage	+10 VDC, 0, -10 VDC $\pm 0.5 \%$ (Full Scale Range) at 25 °C (77 °F). Temperature coefficient: $\pm 100 \text{ ppm}/^{\circ}\text{C}$ ($\pm 56 \text{ ppm}/^{\circ}\text{F}$) max.
Maximum load	10 mA
Applicable potentiometer	1 kohm to 10 kohm

Auxiliary power output

Voltage	24 VDC $\pm 10 \%$, short circuit proof
Maximum current	250 mA (shared between this output and optional modules installed on the RMIO)

Analogue outputs

	Two programmable current outputs: 0 (4) to 20 mA, $R_L \leq 700 \text{ ohm}$
Resolution	0.1 % (10 bit)
Inaccuracy	$\pm 1 \%$ (Full Scale Range) at 25 °C (77 °F). Temperature coefficient: $\pm 200 \text{ ppm}/^{\circ}\text{C}$ ($\pm 111 \text{ ppm}/^{\circ}\text{F}$) max.

Digital inputs

	With Standard Application Program six programmable digital inputs (common ground: 24 VDC, -15 % to +20 %) and a start interlock input. Group isolated, can be divided in two isolated groups (see Isolation and grounding diagram below).
	Thermistor input: 5 mA, $< 1.5 \text{ kohm} \hat{=} \text{"1"}$ (normal temperature), $> 4 \text{ kohm} \hat{=} \text{"0"}$ (high temperature), open circuit $\hat{=} \text{"0"}$ (high temperature).
	Internal supply for digital inputs (+24 VDC): short-circuit proof. An external 24 VDC supply can be used instead of the internal supply.
Isolation test voltage	500 VAC, 1 min
Logical thresholds	$< 8 \text{ VDC} \hat{=} \text{"0"}$, $> 12 \text{ VDC} \hat{=} \text{"1"}$
Input current	DI1 to DI 5: 10 mA, DI6: 5 mA
Filtering time constant	1 ms

Relay outputs

	Three programmable relay outputs
Switching capacity	8 A at 24 VDC or 250 VAC, 0.4 A at 120 VDC
Minimum continuous current	5 mA rms at 24 VDC
Maximum continuous current	2 A rms
Isolation test voltage	4 kVAC, 1 minute

DDCS fibre optic link

With optional communication adapter module RDCO. Protocol: DDCS (ABB Distributed Drives Communication System)

24 VDC power input

Voltage	24 VDC \pm 10 %
Typical current consumption (without optional modules)	250 mA
Maximum current consumption	1200 mA (with optional modules inserted)

The terminals on the RMIO board as well as on the optional modules attachable to the board fulfil the Protective Extra Low Voltage (PELV) requirements stated in EN 50178 provided that the external circuits connected to the terminals also fulfil the requirements and the installation site is below 2000 m (6562 ft). Above 2000 m (6562 ft), see page [51](#).

Isolation and grounding diagram

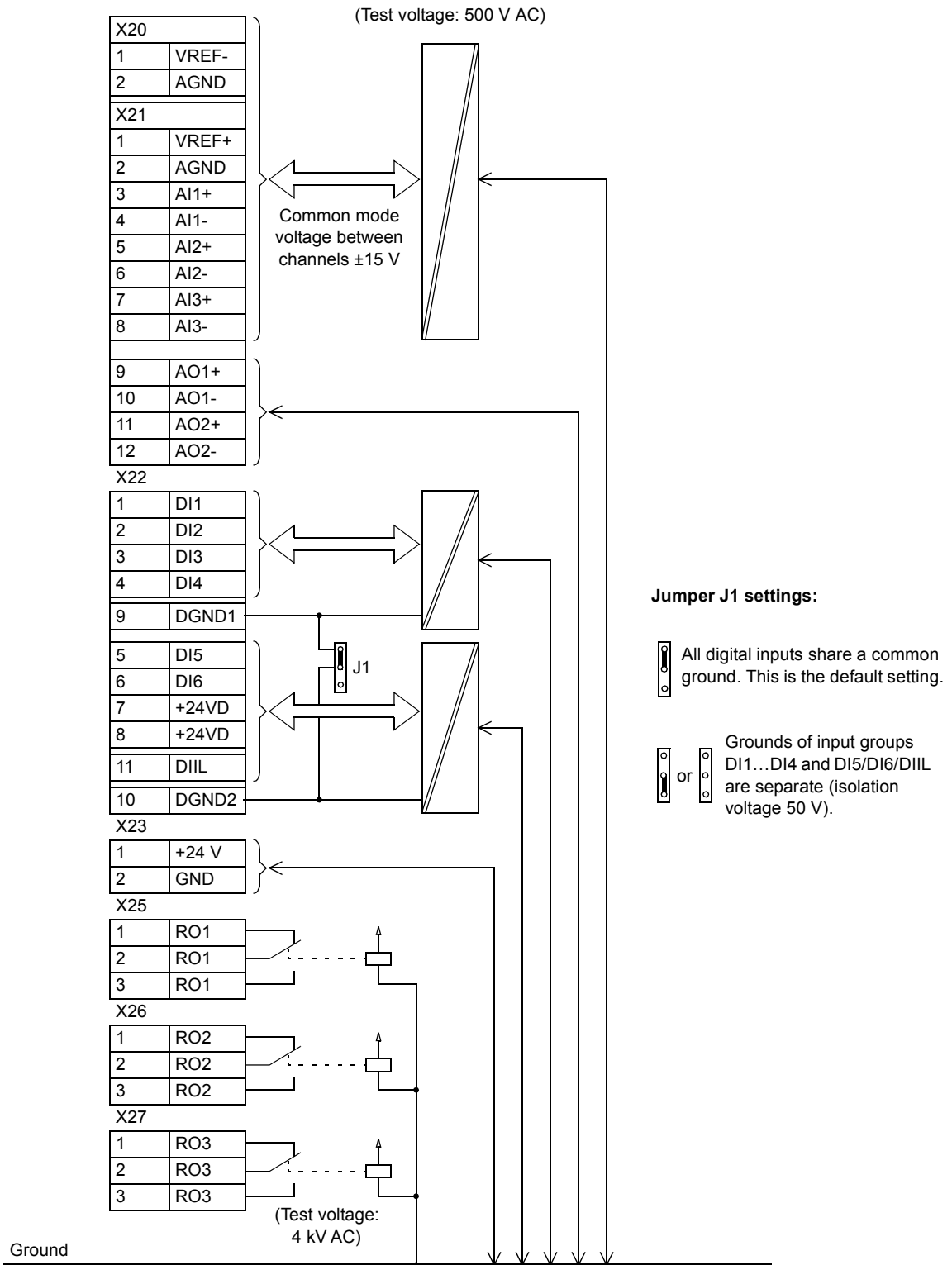

Installation checklist

Checklist

Check the mechanical and electrical installation of the drive before start-up. Go through the checklist below together with another person. Read the [Safety instructions](#) on the first pages of this manual before you work on the unit.

Check
<p>MECHANICAL INSTALLATION</p> <ul style="list-style-type: none"> <input type="checkbox"/> The ambient operating conditions are allowed. (See Mechanical installation, Technical data: IEC data or NEMA data, Ambient conditions.) <input type="checkbox"/> The unit is fixed properly on a vertical non-flammable wall. (See Mechanical installation.) <input type="checkbox"/> The cooling air will flow freely. <input type="checkbox"/> The motor and the driven equipment are ready for start. (See Planning the electrical installation: Motor selection and compatibility, Technical data: Motor connection.) <p>ELECTRICAL INSTALLATION (See Planning the electrical installation, Electrical installation.)</p> <ul style="list-style-type: none"> <input type="checkbox"/> The +E202 and +E200 EMC filter capacitors are disconnected if the drive is connected to an IT (ungrounded) system. <input type="checkbox"/> The capacitors are reformed if stored over one year (refer to ACS 600/800 Capacitor Reforming Guide [64059629 (English)]). <input type="checkbox"/> The drive is grounded properly. <input type="checkbox"/> The mains (input power) voltage matches the drive nominal input voltage. <input type="checkbox"/> The mains (input power) connections at U1, V1 and W1 and their tightening torques are OK. <input type="checkbox"/> Appropriate mains (input power) fuses and disconnectors are installed. <input type="checkbox"/> The motor connections at U2, V2 and W2 and their tightening torques are OK. <input type="checkbox"/> The motor cable is routed away from other cables. <input type="checkbox"/> There are no power factor compensation capacitors in the motor cable. <input type="checkbox"/> The external control connections inside the drive are OK. <input type="checkbox"/> There are no tools, foreign objects or dust from drilling inside the drive. <input type="checkbox"/> Mains (input power) voltage cannot be applied to the output of the drive (with bypass connection). <input type="checkbox"/> Drive, motor connection box and other covers are in place.

Maintenance

What this chapter contains

This chapter contains preventive maintenance instructions.

Safety



WARNING! Read the [Safety instructions](#) on the first pages of this manual before performing any maintenance on the equipment. Ignoring the safety instructions can cause injury or death.

Maintenance intervals

If installed in an appropriate environment, the drive requires very little maintenance. This table lists the routine maintenance intervals recommended by ABB.

Maintenance	Interval	Instruction
Capacitor reforming	Every year when stored	See Reforming .
Heatsink temperature check and cleaning	Depends on the dustiness of the environment (every 6 to 12 months)	See Heatsink .
Cooling fan change	Every six years	See Fan .
Change of additional cooling fan in IP 55 units and in IP 21 units when included	Every three years	See Additional fan .
Frame size R4 and up: capacitor change	Every ten years	See Capacitors .

Heatsink

The heatsink fins pick up dust from the cooling air. The drive runs into overtemperature warnings and faults if the heatsink is not clean. In a “normal” environment (not dusty, not clean) the heatsink should be checked annually, in a dusty environment more often.

Clean the heatsink as follows (when necessary):

1. Remove the cooling fan (see section [Fan](#)).
2. Blow clean compressed air (not humid) from bottom to top and simultaneously use a vacuum cleaner at the air outlet to trap the dust. **Note:** If there is a risk of the dust entering adjoining equipment, perform the cleaning in another room.
3. Replace the cooling fan.

Fan

The cooling fan lifespan of the drive is about 50 000 operating hours. The actual lifespan depends on the drive usage and ambient temperature. See the appropriate ACS800 firmware manual for an actual signal which indicates the hours of usage of the fan. For resetting the running time signal after a fan replacement, please contact ABB.

Fan failure can be predicted by the increasing noise from fan bearings and the gradual rise in the heatsink temperature in spite of heatsink cleaning. If the drive is operated in a critical part of a process, fan replacement is recommended once these symptoms start appearing. Replacement fans are available from ABB. Do not use other than ABB specified spare parts.

Fan replacement (R2, R3)

To remove the fan, release the retaining clips. Disconnect the cable. Install the new fan in reverse order.

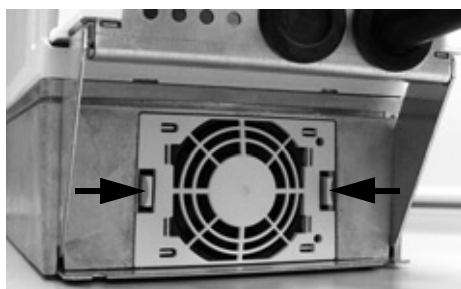

Bottom view

Fan replacement (R4)

1. Loosen the screws that fasten the fan mounting plate to the frame.
2. Push the fan mounting plate to the left and pull it out.
3. Disconnect the fan power cable.
4. Undo the screws that fasten the fan to the fan mounting plate.
5. Install the new fan in reverse order.

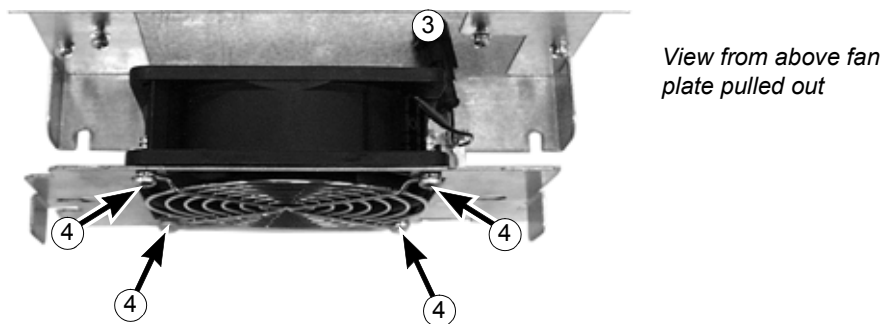
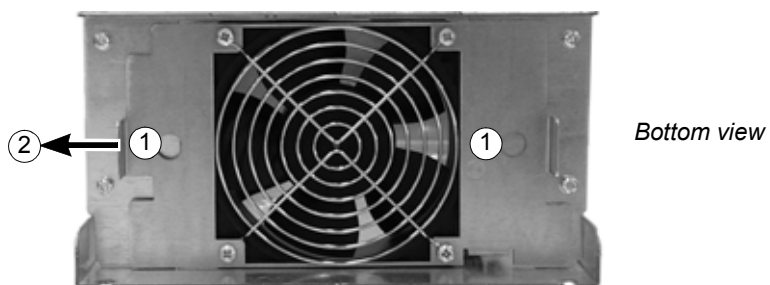

Fan replacement (R5)

1. Undo the fastening screws of the swing-out frame.
2. Open the swing-out frame.
3. Disconnect the cable.
4. Undo the fastening screws of the fan.
5. Install the new fan in reverse order.

Bottom view

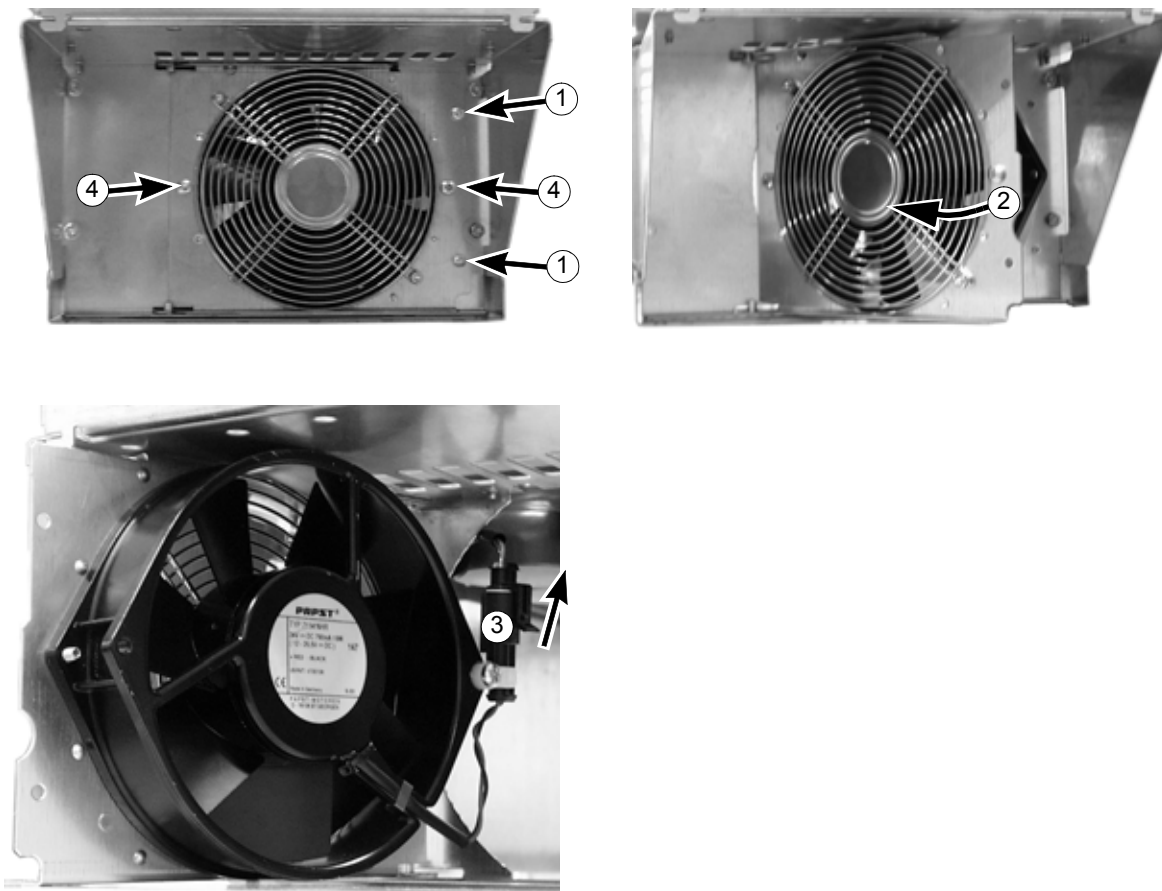

Fan replacement (R6)

To remove the fan, undo the fixing screws. Disconnect the cable. Install the new fan in reverse order.

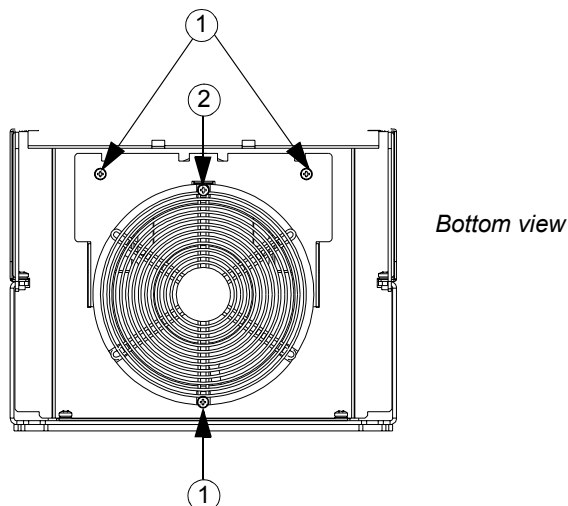

Additional fan

There is an additional cooling fan in all IP 55 units and most IP 21 units. However, there is no additional fan in the following IP 21 units: -0050-2 to -0070-2, -0003-3 to -0005-3, -0070-3 to -0120-3, -0004-5 to -0006-5, -0100-5 to -0140-5.

Replacement (R2, R3)

Remove the front cover. To remove the fan, release the retaining clip (1). Disconnect the cable (2, detachable terminal). Install the new fan in reverse order.

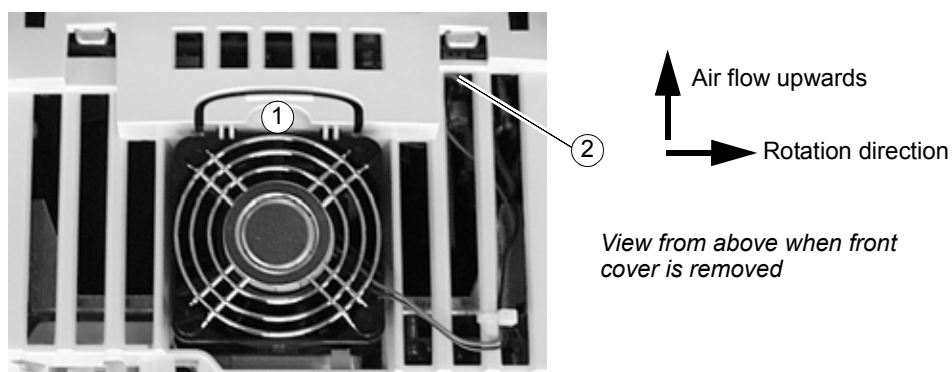

Replacement (R4, R5)

Remove the front cover. The fan is located on the lower right-hand side of the unit (R4) or on the right-hand side of the control panel (R5). Lift the fan out and disconnect the cable. Install the fan in reverse order.

Replacement (R6)

Remove the top cover by lifting it by the rear edge. To remove the fan, release the retaining clips by pulling the back edge (1) of the fan upwards. Disconnect the cable (2, detachable terminal). Install the new fan in reverse order.

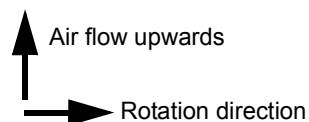
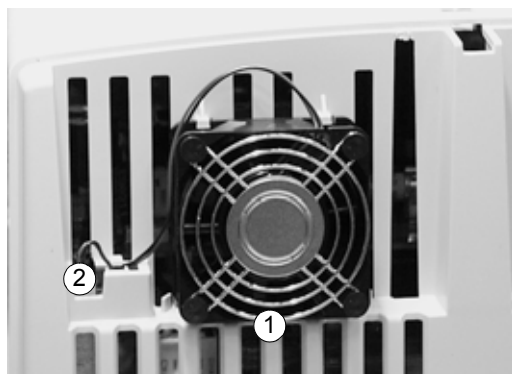

View from above when top cover is removed

Capacitors

The drive intermediate circuit employs several electrolytic capacitors. Their lifespan is from 45 000 to 90 000 hours depending on drive loading and ambient temperature. Capacitor life can be prolonged by lowering the ambient temperature.

It is not possible to predict a capacitor failure. Capacitor failure is usually followed by a mains fuse failure or a fault trip. Contact ABB if capacitor failure is suspected. Replacements for frame size R4 and up are available from ABB. Do not use other than ABB specified spare parts.

Reforming

Reform (re-age) spare part capacitors once a year according to *ACS 600/800 Capacitor Reforming Guide* (code: 64059629).

LEDs

This table describes LEDs of the drive.

Where	LED	When the LED is lit
RMIO board *	Red	Drive in fault state
	Green	The power supply on the board is OK.
Control panel mounting platform (with type code selection +0J400 only)	Red	Drive in fault state
	Green	The main +24 V power supply for the control panel and the RMIO board is OK.

* The LEDs are not visible in frame sizes R2 to R6.

Technical data

What this chapter contains

This chapter contains the technical specifications of the drive, e.g. the ratings, sizes and technical requirements, provisions for fulfilling the requirements for CE and other markings and warranty policy.

IEC data

Ratings

The IEC ratings for the ACS800-01 with 50 Hz and 60 Hz supplies are given below. The symbols are described below the table.

ACS800-01 size	Nominal ratings		No-overload use	Light-overload use		Heavy-duty use		Frame size	Air flow m ³ /h	Heat dissipation W
	$I_{\text{cont.max}}$ A	I_{max} A	$P_{\text{cont.max}}$ kW	I_{2N} A	P_N kW	I_{2hd} A	P_{hd} kW			
Three-phase supply voltage 208 V, 220 V, 230 V or 240 V										
-0001-2	5.1	6.5	1.1	4.7	0.75	3.4	0.55	R2	35	100
-0002-2	6.5	8.2	1.5	6.0	1.1	4.3	0.75	R2	35	100
-0003-2	8.5	10.8	1.5	7.7	1.5	5.7	1.1	R2	35	100
-0004-2	10.9	13.8	2.2	10.2	2.2	7.5	1.5	R2	35	120
-0005-2	13.9	17.6	3	12.7	3	9.3	2.2	R2	35	140
-0006-2	19	24	4	18	4	14	3	R3	69	160
-0009-2	25	32	5.5	24	5.5	19	4	R3	69	200
-0011-2	34	46	7.5	31	7.5	23	5.5	R3	69	250
-0016-2	44	62	11	42	11	32	7.5	R4	103	340
-0020-2	55	72	15	50	11	37	7.5	R4	103	440
-0025-2	72	86	18.5	69	18.5	49	11	R5	250	530
-0030-2	86	112	22	80	22	60	15	R5	250	610
-0040-2	103	138	30	94	22	69	18.5	R5	250	810
-0050-2	141	164	37	132	37	97	30	R6	405	1190
-0060-2	166	202	45	155	45	115	30	R6	405	1190
-0070-2	202	282	55	184	55	141	37	R6	405	1440

ACS800-01 size	Nominal ratings		No-overload use	Light-overload use		Heavy-duty use		Frame size	Air flow m ³ /h	Heat dissipation W
	I _{cont.max} A	I _{max} A	P _{cont.max} kW	I _{2N} A	P _N kW	I _{2hd} A	P _{hd} kW			
Three-phase supply voltage 380 V, 400 V or 415 V										
-0003-3	5.1	6.5	1.5	4.7	1.5	3.4	1.1	R2	35	100
-0004-3	6.5	8.2	2.2	5.9	2.2	4.3	1.5	R2	35	120
-0005-3	8.5	10.8	3	7.7	3	5.7	2.2	R2	35	140
-0006-3	10.9	13.8	4	10.2	4	7.5	3	R2	35	160
-0009-3	13.9	17.6	5.5	12.7	5.5	9.3	4	R2	35	200
-0011-3	19	24	7.5	18	7.5	14	5.5	R3	69	250
-0016-3	25	32	11	24	11	19	7.5	R3	69	340
-0020-3	34	46	15	31	15	23	11	R3	69	440
-0025-3	44	62	22	41	18.5	32	15	R4	103	530
-0030-3	55	72	30	50	22	37	18.5	R4	103	610
-0040-3	72	86	37	69	30	49	22	R5	250	810
-0050-3	86	112	45	80	37	60	30	R5	250	990
-0060-3	103	138	55	94	45	69	37	R5	250	1190
-0070-3	141	164	75	132	55	97	45	R6	405	1440
-0100-3	166	202	90	155	75	115	55	R6	405	1940
-0120-3	202	282	110	184	90	141	75	R6	405	2310
Three-phase supply voltage 380 V, 400 V, 415 V, 440 V, 460 V, 480 V or 500 V										
-0004-5	4.9	6.5	2.2	4.5	2.2	3.4	1.5	R2	35	120
-0005-5	6.2	8.2	3	5.6	3	4.2	2.2	R2	35	140
-0006-5	8.1	10.8	4	7.7	4	5.6	3	R2	35	160
-0009-5	10.5	13.8	5.5	10	5.5	7.5	4	R2	35	200
-0011-5	13.2	17.6	7.5	12	7.5	9.2	5.5	R2	35	250
-0016-5	19	24	11	18	11	13	7.5	R3	69	340
-0020-5	25	32	15	23	15	18	11	R3	69	440
-0025-5	34	46	18.5	31	18.5	23	15	R3	69	530
-0030-5	42	62	22	39	22	32	18.5	R4	103	610
-0040-5	48	72	30	44	30	36	22	R4	103	810
-0050-5	65	86	37	61	37	50	30	R5	250	990
-0060-5	79	112	45	75	45	60	37	R5	250	1190
-0070-5	96	138	55	88	55	69	45	R5	250	1440
-0100-5	124	164	75	115	75	88	55	R6	405	1940
-0120-5	157	202	90	145	90	113	75	R6	405	2310
-0140-5	180	282	110	163	110	141	90	R6	405	2810
Three-phase supply voltage 525 V, 550 V, 575 V, 600 V, 660 V or 690 V										
-0011-7	13	14	11	11.5	7.5	8.5	5.5	R4	103	300
-0016-7	17	19	15	15	11	11	7.5	R4	103	340
-0020-7	22	28	18.5	20	15	15	11	R4	103	440
-0025-7	25	38	22	23	18.5	19	15	R4	103	530
-0030-7	33	44	30	30	22	22	18.5	R4	103	610
-0040-7	36	54	30	34	30	27	22	R4	103	690
-0050-7	51	68	45	46	37	34	30	R5	250	840
-0060-7	57	84	55	52	45	42	37	R5	250	1010
-0070-7	79	104	75	73	55	54	45	R6	405	1220
-0100-7	93	124	90	86	75	62	55	R6	405	1650
-0120-7	113	172	110	108	90	86	75	R6	405	1960

PDM code: 00096931-C

Symbols

Nominal ratings

$I_{\text{cont.max}}$ continuous rms output current. No overload capability at 40 °C.

I_{max} maximum output current. Available for 10 s at start, otherwise as long as allowed by drive temperature.

Typical ratings:

No-overload use

$P_{\text{cont.max}}$ typical motor power. The power ratings apply to most IEC 34 motors at the nominal voltage, 230 V, 400 V, 500 V or 690 V.

Light-overload use (10 % overload capability)

I_{2N} continuous rms current. 10 % overload is allowed for one minute every 5 minutes.

P_N typical motor power. The power ratings apply to most IEC 34 motors at the nominal voltage, 230 V, 400 V, 500 V or 690 V.

Heavy-duty use (50 % overload capability)

I_{2hd} continuous rms current. 50 % overload is allowed for one minute every 5 minutes.

P_{hd} typical motor power. The power ratings apply to most IEC 34 motors at the nominal voltage, 230 V, 400 V, 500 V or 690 V.

Sizing

The current ratings are the same regardless of the supply voltage within one voltage range. To achieve the rated motor power given in the table, the rated current of the drive must be higher than or equal to the rated motor current.

Note 1: The maximum allowed motor shaft power is limited to $1.5 \cdot P_{hd}$, $1.1 \cdot P_N$ or $P_{\text{cont.max}}$ (whichever value is greatest). If the limit is exceeded, motor torque and current are automatically restricted. The function protects the input bridge of the drive against overload. If the condition exists for 5 minutes, the limit is set to $P_{\text{cont.max}}$.

Note 2: The ratings apply at an ambient temperature of 40 °C (104 °F). At lower temperatures the ratings are higher (except I_{max}).

Note 3: Use the DriveSize PC tool for a more accurate dimensioning if the ambient temperature is below 40 °C (104 °F) or the drive is loaded cyclically.

Derating

The load capacity (current and power) decreases if the installation site altitude exceeds 1000 metres (3300 ft), or if the ambient temperature exceeds 40 °C (104 °F).

Temperature derating

In the temperature range +40 °C (+104 °F) to +50 °C (+122 °F) the rated output current is decreased 1 % for every additional 1 °C (1.8 °F). The output current is calculated by multiplying the current given in the rating table by the derating factor.

Example If the ambient temperature is 50 °C (+122 °F), the derating factor is $100 \% - 1 \frac{\%}{\text{°C}} \cdot 10 \text{ °C} = 90 \%$ or 0.90. The output current is then $0.90 \cdot I_{2N}$ or $0.90 \cdot I_{2hd}$.

Altitude derating

In altitudes from 1000 to 4000 m (3300 to 13123 ft) above sea level, the derating is 1 % for every 100 m (328 ft). For a more accurate derating, use the DriveSize PC tool.

Mains cable fuses

Fuses for short-circuit protection of the mains cable are listed below. The fuses also protect the adjoining equipment of the drive in case of a short-circuit. **Check that the operating time of the fuse is below 0.5 seconds.** The operating time depends on the supply network impedance and the cross-sectional area and length of the supply cable. See also *Planning the electrical installation: Thermal overload and short-circuit protection*. For UL recognized fuses, see *NEMA data* on page 92.

Note 1: In multicable installations, install only one fuse per phase (not one fuse per conductor).

Note 2: Larger fuses must not be used.

Note 3: Fuses from other manufacturers can be used if they meet the ratings.

ACS800-01 size	Input current	Fuse					
		A	A ² s *	V	Manufacturer	Type	IEC size
Three-phase supply voltage 208 V, 220 V, 230 V or 240 V							
-0001-2	4.4	10	483	500	ABB Control	OFAF000H10	000
-0002-2	5.2	10	483	500	ABB Control	OFAF000H10	000
-0003-2	6.7	10	483	500	ABB Control	OFAF000H10	000
-0004-2	9.3	16	993	500	ABB Control	OFAF000H16	000
-0005-2	12	16	993	500	ABB Control	OFAF000H16	000
-0006-2	16	20	1620	500	ABB Control	OFAF000H20	000
-0009-2	23	25	3100	500	ABB Control	OFAF000H25	000
-0011-2	31	40	9140	500	ABB Control	OFAF000H40	000
-0016-2	40	50	15400	500	ABB Control	OFAF000H50	000
-0020-2	51	63	21300	500	ABB Control	OFAF000H63	000
-0025-2	67	80	34500	500	ABB Control	OFAF000H80	000
-0030-2	81	100	63600	500	ABB Control	OFAF000H100	000
-0040-2	101	125	103000	500	ABB Control	OFAF000H125	00
-0050-2	138	160	200000	500	ABB Control	OFAF000H160	00
-0060-2	163	200	350000	500	ABB Control	OFAF1H200	1
-0070-2	202	224	420000	500	ABB Control	OFAF1H224	1
Three-phase supply voltage 380 V, 400 V or 415 V							
-0003-3	4.7	10	483	500	ABB Control	OFAF000H10	000
-0004-3	6.0	10	483	500	ABB Control	OFAF000H10	000
-0005-3	7.9	10	483	500	ABB Control	OFAF000H10	000
-0006-3	10	16	993	500	ABB Control	OFAF000H16	000
-0009-3	13	16	993	500	ABB Control	OFAF000H16	000
-0011-3	17	20	1620	500	ABB Control	OFAF000H20	000
-0016-3	23	25	3100	500	ABB Control	OFAF000H25	000
-0020-3	32	40	9140	500	ABB Control	OFAF000H40	000
-0025-3	42	50	15400	500	ABB Control	OFAF000H50	000
-0030-3	53	63	21300	500	ABB Control	OFAF000H63	000
-0040-3	69	80	34500	500	ABB Control	OFAF000H80	000
-0050-3	83	100	63600	500	ABB Control	OFAF000H100	000
-0060-3	100	125	103000	500	ABB Control	OFAF000H125	00
-0070-3	138	160	200000	500	ABB Control	OFAF000H160	00
-0100-3	163	200	350000	500	ABB Control	OFAF1H200	1
-0120-3	198	224	420000	500	ABB Control	OFAF1H224	1

ACS800-01 size	Input current	Fuse					
		A	A ² s *	V	Manufacturer	Type	IEC size
Three-phase supply voltage 380 V, 400 V, 415 V, 440 V, 460 V, 480 V or 500 V							
-0004-5	4.7	10	483	500	ABB Control	OFAF000H10	000
-0005-5	5.9	10	483	500	ABB Control	OFAF000H10	000
-0006-5	7.7	10	483	500	ABB Control	OFAF000H10	000
-0009-5	10.0	16	993	500	ABB Control	OFAF000H16	000
-0011-5	12.5	16	993	500	ABB Control	OFAF000H16	000
-0016-5	17	20	1620	500	ABB Control	OFAF000H20	000
-0020-5	23	25	3100	500	ABB Control	OFAF000H25	000
-0025-5	31	40	9140	500	ABB Control	OFAF000H40	000
-0030-5	41	50	15400	500	ABB Control	OFAF000H50	000
-0040-5	47	63	21300	500	ABB Control	OFAF000H63	000
-0050-5	64	80	34500	500	ABB Control	OFAF000H80	000
-0060-5	78	100	63600	500	ABB Control	OFAF000H100	000
-0070-5	95	125	103000	500	ABB Control	OFAF000H125	00
-0100-5	121	160	200000	500	ABB Control	OFAF000H160	00
-0120-5	155	200	350000	500	ABB Control	OFAF1H200	1
-0140-5	180	200	350000	500	ABB Control	OFAF1H200	1
Three-phase supply voltage 525 V, 550 V, 575 V, 600 V, 660 V or 690 V							
-0011-7	12	16	1100	690	ABB Control	OFAA000GG16	000
-0016-7	15	20	2430	690	ABB Control	OFAA000GG20	000
-0020-7	21	25	4000	690	ABB Control	OFAA000GG25	000
-0025-7	24	32	7000	690	ABB Control	OFAA000GG32	000
-0030-7	33	35	11400	690	ABB Control	OFAA000GG35	000
-0040-7	35	50	22800	690	ABB Control	OFAA000GG50	000
-0050-7	52	63	28600	690	ABB Control	OFAA0GG63	0
-0060-7	58	63	28600	690	ABB Control	OFAA0GG63	0
-0070-7	79	80	52200	690	ABB Control	OFAA0GG80	0
-0100-7	91	100	93000	690	ABB Control	OFAA1GG100	1
-0120-7	112	125	126000	690	ABB Control	OFAA1GG125	1

PDM code: 00096931-G

* maximum total I^2t value for 550 V

Cable types

The table below gives copper and aluminium cable types for different load currents. Cable sizing is based on max. 9 cables laid on a cable ladder side by side, ambient temperature 30 °C, PVC insulation, surface temperature 70 °C (EN 60204-1 and IEC 60364-5-2/2001). For other conditions, size the cables according to local safety regulations, appropriate input voltage and the load current of the drive.

Copper cables with concentric copper shield		Aluminium cables with concentric copper shield	
Max. load current A	Cable type mm ²	Max. load current A	Cable type mm ²
14	3x1.5	61	3x25
20	3x2.5	75	3x35
27	3x4	91	3x50
34	3x6	117	3x70
47	3x10	143	3x95
62	3x16	165	3x120
79	3x25	191	3x150
98	3x35	218	3x185
119	3x50	257	3x240
153	3x70	274	3 x (3x50)
186	3x95	285	2 x (3x95)
215	3x120		
249	3x150		
284	3x185		

PDM code: 00096931-C

Cable entries

Brake resistor, mains and motor cable terminal sizes (per phase), accepted cable diameters and tightening torques are given below.

Frame size	U1, V1, W1, U2, V2, W2, R+, R-				Earthing PE	
	Wire size mm ²	Max. cable Ø IP 21 mm	Cable Ø IP 55 mm	Tightening torque Nm	Wire size mm ²	Tightening torque Nm
R2	up to 16*	21	14...20	1.2...1.5	up to 10	1.5
R3	up to 16*	21	14...20	1.2...1.5	up to 10	1.5
R4	up to 25	29	23...35	2...4	up to 16	3.0
R5	6...70	35	23...35	15	6...70	15
R6	95...185 **	53	30...45	20...40	95	8

* 16 mm² rigid solid cable, 10 mm² flexible stranded cable

** with cable lugs 16...70 mm², tightening torque 20...40 Nm. Cable lugs are not included in the delivery. See page 59.

Dimensions, weights and noise

H1 height with cable connection box, H2 height without cable connection box.

Frame size	IP 21					IP 55				Noise dB
	H1 mm	H2 mm	Width mm	Depth mm	Weight kg	Height mm	Width mm	Depth mm	Weight kg	
R2	405	370	165	226	9	528	263	241	16	62
R3	471	420	173	265	14	528	263	273	18	62
R4	607	490	240	274	26	774	377	278	33	62
R5	739	602	265	286	34	775	377	308	51	65
R6	880	700	300	399	67	923	420	420	77	65

NEMA data

Ratings

The NEMA ratings for the ACS800-U1 with 60 Hz supplies are given below. The symbols are described below the table. For sizing, derating and 50 Hz supplies, see [IEC data](#) on page 85.

ACS800-U1 size	I_{max} A	Normal use		Heavy-duty use		Frame size	Air flow ft ³ /min	Heat dissipation BTU/Hr
		I_{2N} A	P_N HP	I_{2hd} A	P_{hd} HP			
Three-phase supply voltage 208 V, 220 V, 230 V or 240 V								
-0002-2	8.2	6.6	1.5	4.6	1	R2	21	350
-0003-2	10.8	8.1	2	6.6	1.5	R2	21	350
-0004-2	13.8	11	3	7.5	2	R2	21	410
-0006-2	24	21	5	13	3	R3	41	550
-0009-2	32	27	7.5	17	5	R3	41	680
-0011-2	46	34	10	25	7.5	R3	41	850
-0016-2	62	42	15	31	10	R4	61	1150
-0020-2	72	54	20 *	42	15 **	R4	61	1490
-0025-2	86	69	25	54	20 **	R5	147	1790
-0030-2	112	80	30	68	25 **	R5	147	2090
-0040-2	138	104	40 *	80	30 **	R5	147	2770
-0050-2	164	132	50	104	40	R6	238	3370
-0060-2	202	157	60	130	50 **	R6	238	4050
-0070-2	282	192	75	154	60 **	R6	238	4910
Three-phase supply voltage 380 V, 400 V, 415 V, 440 V, 460 V or 480 V								
-0004-5	6.5	4.9	3	3.4	2	R2	21	410
-0005-5	8.2	6.2	3	4.2	2	R2	21	480
-0006-5	10.8	8.1	5	5.6	3	R2	21	550
-0009-5	13.8	11	7.5	8.1	5	R2	21	690
-0011-5	17.6	14	10	11	7.5	R2	21	860
-0016-5	24	21	15	15	10	R3	41	1150
-0020-5	32	27	20	21	15	R3	41	1490
-0025-5	46	34	25	27	20	R3	41	1790
-0030-5	62	42	30	34	25	R4	61	2090
-0040-5	72	52	40	37	30 ***	R4	61	2770
-0050-5	86	65	50	52	40	R5	147	3370
-0060-5	112	79	60	65	50	R5	147	4050
-0070-5	138	96	75	77	60	R5	147	4910
-0100-5	164	124	100	96	75	R6	238	6610
-0120-5	202	157	125	124	100	R6	238	7890
-0140-5	282	180	150	156	125	R6	238	9600
Three-phase supply voltage 525 V, 575 V , 600 V								
-0011-7	14	11.5	10	8.5	7.5	R4	61	1050
-0016-7	19	15	10	11	10	R4	61	1200
-0020-7	28	20	15/20 ****	15	15**	R4	61	1550
-0025-7	38	23	20	20	20**	R4	61	1850
-0030-7	44	30	25/30 ****	25	25**	R4	61	2100
-0040-7	54	34	30	30	30**	R4	61	2400
-0050-7	68	46	40	40	40**	R5	147	2900
-0060-7	84	52	50	42	40	R5	147	3450
-0070-7	104	73	60	54	50	R6	238	4200
-0100-7	124	86	75	62	60	R6	238	5650
-0120-7	172	108	100	86	75	R6	238	6700

PDM code: 00096931-C

- * Overload may be limited to 5 % at high speeds (> 90 % speed) by the internal power limit of the drive. The limitation also depends on motor characteristics and network voltage.
- ** Overload may be limited to 40 % at high speeds (> 90 % speed) by the internal power limit of the drive. The limitation also depends on motor characteristics and network voltage.
- *** special 4-pole high-efficiency NEMA motor
- **** higher rating is available with special 4-pole high-efficiency NEMA motor

Symbols

Nominal ratings

I_{\max} maximum output current. Available for 10 s at start, otherwise as long as allowed by drive temperature.

Normal use (10 % overload capability)

I_{2N} continuous rms current. 10 % overload is typically allowed for one minute every 5 minutes.

P_N typical motor power. The power ratings apply to most 4-pole NEMA rated motors (230 V, 460 V or 575 V).

Heavy-duty use (50 % overload capability)

I_{2hd} continuous rms current. 50 % overload is typically allowed for one minute every 5 minutes.

P_{hd} typical motor power. The power ratings apply to most 4-pole NEMA rated motors (230 V, 460 V or 575 V).

Note 1: The ratings apply at an ambient temperature of 40 °C (104 °F). In lower temperatures the ratings are higher (except I_{\max}).

Input cable fuses

The ratings of UL listed fuses for branch circuit protection are listed below. The fuses also prevent damage to the adjoining equipment of the drive in case of a short-circuit inside the drive. **Check that the operating time of the fuse is below 0.5 seconds.** The operating time depends on the supply network impedance and the cross-sectional area and length of the supply cable. The fuses must be of the “non-time delay” type. See also *Planning the electrical installation: [Thermal overload and short-circuit protection](#)*.

Note 1: In multicable installations, install only one fuse per phase (not one fuse per conductor).

Note 2: Larger fuses must not be used.

Note 3: Fuses from other manufacturers can be used if they meet the ratings.

ACS800-U1 type	Input current A	Fuse				
		A	V	Manufacturer	Type	UL class
Three-phase supply voltage 208 V, 220 V, 230 V or 240 V						
-0002-2	5.2	10	600	Bussmann	JJS-10	T
-0003-2	6.5	10	600	Bussmann	JJS-10	T
-0004-2	9.2	15	600	Bussmann	JJS-15	T
-0006-2	18	25	600	Bussmann	JJS-25	T
-0009-2	24	30	600	Bussmann	JJS-30	T
-0011-2	31	40	600	Bussmann	JJS-40	T
-0016-2	38	50	600	Bussmann	JJS-50	T
-0020-2	49	70	600	Bussmann	JJS-70	T
-0025-2	64	90	600	Bussmann	JJS-90	T
-0030-2	75	100	600	Bussmann	JJS-100	T
-0040-2	102	125	600	Bussmann	JJS-125	T
-0050-2	126	175	600	Bussmann	JJS-175	T
-0060-2	153	200	600	Bussmann	JJS-200	T
-0070-2	190	250	600	Bussmann	JJS-250	T
Three-phase supply voltage 380 V, 400 V, 415 V, 440 V, 460 V , 480 V or 500 V						
-0004-5	4.1	10	600	Bussmann	JJS-10	T
-0005-5	5.4	10	600	Bussmann	JJS-10	T
-0006-5	6.9	10	600	Bussmann	JJS-10	T
-0009-5	9.8	15	600	Bussmann	JJS-15	T
-0011-5	13	20	600	Bussmann	JJS-20	T
-0016-5	18	25	600	Bussmann	JJS-25	T
-0020-5	24	35	600	Bussmann	JJS-35	T
-0025-5	31	40	600	Bussmann	JJS-40	T
-0030-5	40	50	600	Bussmann	JJS-50	T
-0040-5	52	70	600	Bussmann	JJS-70	T
-0050-5	63	80	600	Bussmann	JJS-80	T
-0060-5	77	100	600	Bussmann	JJS-100	T
-0070-5	94	125	600	Bussmann	JJS-125	T
-0100-5	121	150	600	Bussmann	JJS-150	T
-0120-5	155	200	600	Bussmann	JJS-200	T
-0140-5	179	225	600	Bussmann	JJS-225	T
Three-phase supply voltage 525 V, 575 V , 600 V						
-0011-7	10	20	600	Bussmann	JJS-20	T
-0016-7	13	20	600	Bussmann	JJS-20	T
-0020-7	19	30	600	Bussmann	JJS-30	T
-0025-7	21	30	600	Bussmann	JJS-30	T
-0030-7	29	45	600	Bussmann	JJS-45	T
-0040-7	32	45	600	Bussmann	JJS-45	T
-0050-7	45	70	600	Bussmann	JJS-70	T
-0060-7	51	80	600	Bussmann	JJS-80	T
-0070-7	70	100	600	Bussmann	JJS-100	T
-0100-7	82	125	600	Bussmann	JJS-125	T
-0120-7	103	150	600	Bussmann	JJS-150	T

PDM code: 00096931-G

Cable types

Cable sizing is based on NEC Table 310-16 for copper wires, 75 °C (167 °F) wire insulation at 40 °C (104 °F) ambient temperature. Not more than three current-carrying conductors in raceway or cable or earth (directly buried). For other conditions, dimension the cables according to local safety regulations, appropriate input voltage and the load current of the drive.

Copper cables with concentric copper shield	
Max. load current A	Cable type AWG/kcmil
18	14
22	12
31	10
44	8
57	6
75	4
88	3
101	2
114	1
132	1/0
154	2/0
176	3/0
202	4/0
224	250 MCM or 2 x 1
251	300 MCM or 2 x 1/0

PDM code: 00096931-C

Cable Entries

Brake resistor, input and motor cable (per phase) terminal sizes, accepted cable diameters and tightening torques are given below.

Frame size	U1, V1, W1, U2, V2, W2, R+, R-			Earthing PE	
	Wire size AWG	Wire Ø (UL type 1) in.	Tightening torque lbf ft	Wire size AWG	Tightening torque lbf ft
R2	up to 6*	0.8	0.9...1.1	up to 8	1.1
R3	up to 6*	0.8	0.9...1.1	up to 8	1.1
R4	up to 4	1.14	1.5...3.0	up to 5	2.2
R5	10...2/0	1.39	11.1	10...2/0	11.1
R6	3/0 ... 350 MCM **	2.09	14.8...29.5	4/0	5.9

* 6 AWG rigid solid cable, 8 AWG flexible stranded cable

** with cable lugs 6...2/0 AWG, tightening torque 14.8...29.5 lbf ft. Cable lugs are not included in the delivery. See page [59](#).

Dimensions, weights and noise

H1 height with gland box, H2 height without gland box.

Frame size	UL type 1					UL type 12			
	H1 in.	H2 in.	Width in.	Depth in.	Weight lb	Height in.	Width in.	Depth in.	Weight lb
R2	15.96	14.57	6.50	8.89	20	20.78	10.35	9.49	34
R3	18.54	16.54	6.81	10.45	31	20.78	10.35	10.74	41
R4	23.87	19.29	9.45	10.79	57	30.49	14.84	10.94	73
R5	29.09	23.70	10.43	11.26	75	30.49	14.84	12.14	112
R6	34.65	27.56	11.81	15.75	148	36.34	16.52	16.54	170

Input power connection

Voltage (U_1)	208/220/230/240 VAC 3-phase $\pm 10\%$ for 230 VAC units 380/400/415 VAC 3-phase $\pm 10\%$ for 400 VAC units 380/400/415/440/460/480/500 VAC 3-phase $\pm 10\%$ for 500 VAC units 525/550/575/600/660/690 VAC 3-phase $\pm 10\%$ for 690 VAC units
Prospective short-circuit current (IEC 60439-1, UL 508C)	Maximum allowed prospective short-circuit current in the supply is 65 kA in a second providing that the mains cable of the drive is protected with appropriate fuses. US and Canada: The drive is suitable for use on a circuit capable of delivering not more than 65 kA rms symmetrical amperes at the drive nominal voltage when protected by CC or T class fuses.
Frequency	48 to 63 Hz, maximum rate of change 17 %/s
Imbalance	Max. $\pm 3\%$ of nominal phase to phase input voltage
Fundamental power factor ($\cos \phi_1$)	0.98 (at nominal load)

Motor connection

Voltage (U_2)	0 to U_1 , 3-phase symmetrical, U_{\max} at the field weakening point
Frequency	DTC mode: 0 to $3.2 \cdot f_{\text{FWP}}$. Maximum frequency 300 Hz. $f_{\text{FWP}} = \frac{U_{\text{Nmains}}}{U_{\text{Nmotor}}} \cdot f_{\text{Nmotor}}$ f_{FWP} : frequency at field weakening point; U_{Nmains} : mains (input power) voltage; U_{Nmotor} : rated motor voltage; f_{Nmotor} : rated motor frequency
Frequency resolution	0.01 Hz
Current	See section IEC data .
Power limit	$1.5 \cdot P_{\text{hd}}$, $1.1 \cdot P_{\text{N}}$ or $P_{\text{cont.max}}$ (whichever value is greatest)
Field weakening point	8 to 300 Hz
Switching frequency	3 kHz (average). In 690 V units 2 kHz (average).

Maximum recommended motor cable length	Sizing method	Max. motor cable length	
		DTC control	Scalar control
	according to I_{2N} and I_{2hd}	R2 to R3: 100 m (328 ft)	R2: 150 m (492 ft)
	according to $I_{cont.max}$ at ambient temperatures below 30 °C (86 °F)	R4 to R6: 300 m (984 ft)	R3 to R6: 300 m (984 ft)
	according to $I_{cont.max}$ at ambient temperatures above 30 °C (86 °F)	R2: 50 m (164 ft) Note: This applies to units with EMC filter also. R3 and R4: 100 m (328 ft) R5 and R6: 150 m (492 ft)	

Note: With cables longer than 100 m (328 ft), the EMC Directive requirements may not be fulfilled. See section [CE marking](#).

Efficiency

Approximately 98 % at nominal power level

Cooling

Method Internal fan, flow direction from bottom to top.

Free space around the unit See chapter [Mechanical installation](#).

Degrees of protection

IP 21 (UL type 1) and IP 55 (UL type 12). Without connection box and front cover, the unit must be protected against contact according to IP 2x [see chapter [Electrical installation: Cabinet installation \(IP 21, UL type 1\)](#)].

Ambient conditions

Environmental limits for the drive are given below. The drive is to be used in a heated, indoor, controlled environment.

	Operation installed for stationary use	Storage in the protective package	Transportation in the protective package
Installation site altitude	0 to 4000 m (13123 ft) above sea level [above 1000 m (3281 ft), see section <i>Derating</i>]	-	-
Air temperature	-15 to +50 °C (5 to 122 °F). No frost allowed. See section <i>Derating</i> .	-40 to +70 °C (-40 to +158 °F)	-40 to +70 °C (-40 to +158 °F)
Relative humidity	5 to 95%	Max. 95%	Max. 95%
	No condensation allowed. Maximum allowed relative humidity is 60% in the presence of corrosive gases.		
Contamination levels (IEC 60721-3-3, IEC 60721-3-2, IEC 60721-3-1)	No conductive dust allowed.		
	Boards without coating: Chemical gases: Class 3C1 Solid particles: Class 3S2 Boards with coating: Chemical gases: Class 3C2 Solid particles: Class 3S2	Boards without coating: Chemical gases: Class 1C2 Solid particles: Class 1S3 Boards with coating: Chemical gases: Class 1C2 Solid particles: Class 1S3	Boards without coating: Chemical gases: Class 2C2 Solid particles: Class 2S2 Boards with coating: Chemical gases: Class 2C2 Solid particles: Class 2S2
Atmospheric pressure	70 to 106 kPa 0.7 to 1.05 atmospheres	70 to 106 kPa 0.7 to 1.05 atmospheres	60 to 106 kPa 0.6 to 1.05 atmospheres
Vibration (IEC 60068-2)	Max. 1 mm (0.04 in.) (5 to 13.2 Hz), max. 7 m/s ² (23 ft/s ²) (13.2 to 100 Hz) sinusoidal	Max. 1 mm (0.04 in.) (5 to 13.2 Hz), max. 7 m/s ² (23 ft/s ²) (13.2 to 100 Hz) sinusoidal	Max. 3.5 mm (0.14 in.) (2 to 9 Hz), max. 15 m/s ² (49 ft/s ²) (9 to 200 Hz) sinusoidal
Shock (IEC 60068-2-29)	Not allowed	Max. 100 m/s ² (330 ft./s ²), 11 ms	Max. 100 m/s ² (330 ft./s ²), 11 ms
Free fall	Not allowed	250 mm (10 in.) for weight under 100 kg (220 lb) 100 mm (4 in.) for weight over 100 kg (220 lb)	250 mm (10 in.) for weight under 100 kg (220 lb) 100 mm (4 in.) for weight over 100 kg (220 lb)

Materials

Drive enclosure	<ul style="list-style-type: none"> • PC/ABS 2.5 mm, colour NCS 1502-Y (RAL 90021 / PMS 420 C) • hot-dip zinc coated steel sheet 1.5 to 2 mm, thickness of coating 100 micrometres • cast aluminium AISi (R2 and R3) • extruded aluminium AISi (R4 to R6)
Package	Corrugated cardboard (IP 21 units of frame sizes R2 to R5 and option modules), plywood (frame size R6 and IP 55 units of frame sizes R4 and R5), expanded polystyrene. Plastic covering of the package: PE-LD, bands PP or steel.
Disposal	<p>The drive contains raw materials that should be recycled to preserve energy and natural resources. The package materials are environmentally compatible and recyclable. All metal parts can be recycled. The plastic parts can either be recycled or burned under controlled circumstances, according to local regulations. Most recyclable parts are marked with recycling marks.</p> <p>If recycling is not feasible, all parts excluding electrolytic capacitors and printed circuit boards can be landfilled. The DC capacitors (C1-1 to C1-x) contain electrolyte and the printed circuit boards contain lead, both of which are classified as hazardous waste within the EU. They must be removed and handled according to local regulations.</p> <p>For further information on environmental aspects and more detailed recycling instructions, please contact your local ABB distributor.</p>

Applicable standards

	The drive complies with the following standards. The compliance with the European Low Voltage Directive is verified according to standards EN 50178 and EN 60204-1.
• EN 50178 (1997)	Electronic equipment for use in power installations
• EN 60204-1 (1997)	Safety of machinery. Electrical equipment of machines. Part 1: General requirements. <i>Provisions for compliance:</i> The final assembler of the machine is responsible for installing - an emergency-stop device - a supply disconnecting device.
• EN 60529: 1991 (IEC 60529)	Degrees of protection provided by enclosures (IP code)
• IEC 60664-1 (1992)	Insulation coordination for equipment within low-voltage systems. Part 1: Principles, requirements and tests.
• EN 61800-3 (1996) + Amendment A11 (2000)	EMC product standard including specific test methods
• EN 61800-3 (2004)	Adjustable speed electrical power drive systems. Part 3: EMC requirements and specific test methods
• UL 508C	UL Standard for Safety, Power Conversion Equipment, second edition
• NEMA 250 (2003)	Enclosures for Electrical Equipment (1000 Volts Maximum)
• CSA C22.2 No. 14-95	Industrial control equipment

CE marking

A CE mark is attached to the drive to verify that the unit follows the provisions of the European Low Voltage and EMC Directives (Directive 73/23/EEC, as amended by 93/68/EEC and Directive 89/336/EEC, as amended by 93/68/EEC).

Definitions

EMC stands for **Electromagnetic Compatibility**. It is the ability of electrical/electronic equipment to operate without problems within an electromagnetic environment. Likewise, the equipment must not disturb or interfere with any other product or system within its locality.

First environment includes establishments connected to a low-voltage network which supplies buildings used for domestic purposes.

Second environment includes establishments connected to a network not supplying domestic premises.

EN 61800-3 + Amendment A11 (2000)

Restricted distribution: mode of sales distribution in which the manufacturer restricts the supply of equipment to suppliers, customers or users who separately or jointly have technical competence in the EMC requirements of the application of drives.

Unrestricted distribution: mode of sales distribution in which the supply of equipment is not dependent on the EMC competence of the customer or user for the application of drives.

EN 61800-3 (2004)

Drive of category C2: drive of rated voltage less than 1000 V and intended to be installed and commissioned only by a professional when used in the first environment. **Note**: A professional is a person or organisation having necessary skills in installing and/or commissioning power drive systems, including their EMC aspects.

Drive of category C3: drive of rated voltage less than 1000 V and intended for use in the second environment and not intended for use in the first environment.

Drive of category C4: drive of rated voltage equal to or above 1000 V, or rated current equal to or above 400 A, or intended for use in complex systems in the second environment.

Compliance with the EMC Directive

The EMC Directive defines the requirements for immunity and emissions of electrical equipment used within the European Union. The EMC product standard [EN 61800-3 + Amendment A11 (2000), EN 61800-3 (2004)] covers requirements stated for drives.

Compliance with the EN 61800-3 + Amendment A11 (2000) and EN 61800-3 (2004)

First environment (restricted distribution, drive of category C2)

The drive complies with the standard with the following provisions:

1. The drive is equipped with EMC filter +E202.
2. The motor and control cables are selected as specified in the *Hardware Manual*.
3. The drive is installed according to the instructions given in the *Hardware Manual*.
4. Maximum cable length is 100 metres.

WARNING! The drive may cause radio interference if used in a residential or domestic environment. The user is required to take measures to prevent interference, in addition to the requirements for CE compliance listed above, if necessary.

Note: It is not allowed to install a drive equipped with EMC filter +E202 on IT (unearthed) systems. The supply network becomes connected to earth potential through the EMC filter capacitors which may cause danger or damage the unit.

Second environment (drive of category C3)

The drive complies with the standard with the following provisions:

1. The drive is equipped with EMC filter +E200. The filter is suitable for TN (earthed) networks only.
2. The motor and control cables are selected as specified in the *Hardware Manual*.
3. The drive is installed according to the instructions given in the *Hardware Manual*.
4. Maximum cable length is 100 metres.

WARNING! A drive of category C3 is not intended to be used on a low-voltage public network which supplies domestic premises. Radio frequency interference is expected if the drive is used on such a network.

Second environment (drive of category C4)

If the provisions under [Second environment \(drive of category C3\)](#) cannot be met, e.g. the drive cannot be equipped with EMC filter +E200 when installed to an IT (unearthed) network, the requirements of the EMC Directive can be met as follows for restricted distribution:

1. It is ensured that no excessive emission is propagated to neighbouring low-voltage networks. In some cases, the inherent suppression in transformers and cables is sufficient. If in doubt, a supply transformer with static screening between the primary and secondary windings can be used.

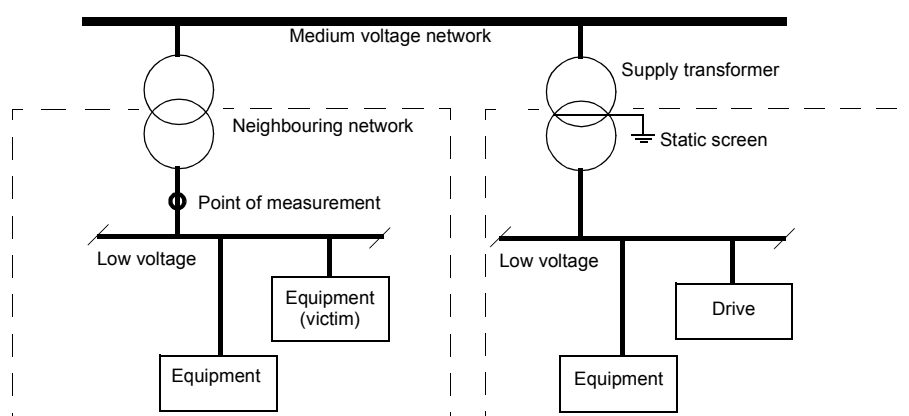

2. An EMC plan for preventing disturbances is drawn up for the installation. A template is available from the local ABB representative.
3. The motor and control cables are selected as specified in the *Hardware Manual*.
4. The drive is installed according to the instructions given in the *Hardware Manual*.

WARNING! A drive of category C4 is not intended to be used on a low-voltage public network which supplies domestic premises. Radio frequency interference is expected if the drive is used on such a network.

Machinery Directive

The drive complies with the European Union Machinery Directive (98/37/EC) requirements for an equipment intended to be incorporated into machinery.

“C-tick” marking

“C-tick” marking is required in Australia and New Zealand. A “C-tick” mark is attached to each drive in order to verify compliance with the relevant standard (IEC 61800-3 (2004) – Adjustable speed electrical power drive systems. Part 3: EMC requirements and specific test methods), mandated by the Trans-Tasman Electromagnetic Compatibility Scheme.

Definitions

EMC stands for **E**lectromagnetic **C**ompatibility. It is the ability of electrical/electronic equipment to operate without problems within an electromagnetic environment. Likewise, the equipment must not disturb or interfere with any other product or system within its locality.

The Trans-Tasman Electromagnetic Compatibility Scheme (EMCS) was introduced by the Australian Communication Authority (ACA) and the Radio Spectrum Management Group (RSM) of the New Zealand Ministry of Economic Development (NZMED) in November 2001. The aim of the scheme is to protect the radiofrequency spectrum by introducing technical limits for emission from electrical/electronic products.

First environment includes establishments connected to a low-voltage network which supplies buildings used for domestic purposes.

Second environment includes establishments connected to a network not supplying domestic premises.

Drive of category C2: drive of rated voltage less than 1000 V and intended to be installed and commissioned only by a professional when used in the first environment. **Note:** A professional is a person or organisation having necessary skills in installing and/or commissioning power drive systems, including their EMC aspects.

Drive of category C3: drive of rated voltage less than 1000 V and intended for use in the second environment and not intended for use in the first environment.

Drive of category C4: drive of rated voltage equal to or above 1000 V, or rated current equal to or above 400 A, or intended for use in complex systems in the second environment.

Compliance with IEC 61800-3

First environment (drive of category C2)

The drive complies with the limits of IEC 61800-3 with the following provisions:

1. The drive is equipped with EMC filter +E202.
2. The drive is installed according to the instructions given in the *Hardware Manual*.
3. The motor and control cables used are selected as specified in the *Hardware Manual*.
4. Maximum cable length is 100 metres.

Note: The drive must not be equipped with EMC filter +E202 when installed to IT (unearthed) systems. The mains becomes connected to earth potential through the EMC filter capacitors. In IT systems this may cause danger or damage the unit.

Second environment (drive of category C3)

The drive complies with the standard with the following provisions:

1. The drive is equipped with EMC filter +E200. The filter is suitable for TN (earthed) networks only.
2. The motor and control cables are selected as specified in the *Hardware Manual*.
3. The drive is installed according to the instructions given in the *Hardware Manual*.
4. Maximum cable length is 100 metres.

WARNING! A drive of category C3 is not intended to be used on a low-voltage public network which supplies domestic premises. Radio frequency interference is expected if the drive is used on such a network.

Second environment (drive of category C4)

If the provisions under [Second environment \(drive of category C3\)](#) cannot be met, e.g. the drive cannot be equipped with EMC filter +E200 when installed to an IT (unearthed) network, the requirements of the EMC Directive can be met as follows for restricted distribution:

1. It is ensured that no excessive emission is propagated to neighbouring low-voltage networks. In some cases, the inherent suppression in transformers and cables is sufficient. If in doubt, a supply transformer with static screening between the primary and secondary windings can be used.

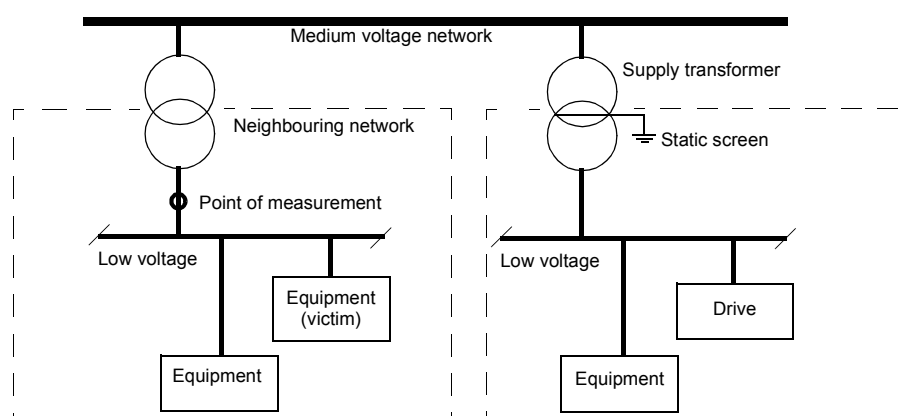

2. An EMC plan for preventing disturbances is drawn up for the installation. A template is available from the local ABB representative.
3. The motor and control cables are selected as specified in the *Hardware Manual*.
4. The drive is installed according to the instructions given in the *Hardware Manual*.

WARNING! A drive of category C4 is not intended to be used on a low-voltage public network which supplies domestic premises. Radio frequency interference is expected if the drive is used on such a network.

Marine type approvals

ACS800-01+C132 and ACS800-U1+C132 units of IP 21, IP 55, UL type 1 and UL type 12 are type approved by American Bureau of Shipping, Bureau Veritas, Germanischer Lloyd, Lloyd's Register of Shipping, Det Norske Veritas and RINA.

UL/CSA markings

The ACS800-01 and ACS800-U1 units of UL type 1 are C-UL US listed and CSA marked. The UL and CSA markings are pending for units of UL type 12.

UL

The drive is suitable for use on a circuit capable of delivering not more than 65 kA rms symmetrical amperes at the drive nominal voltage (600 V maximum for 690 V units).

The drive provides overload protection in accordance with the National Electrical Code (US). See *ACS800 Firmware Manual* for setting. Default setting is off, must be activated at start-up.

The drives are to be used in a heated indoor controlled environment. See section [Ambient conditions](#) for specific limits.

Brake chopper - ABB has brake choppers that, when applied with appropriately sized brake resistors, will allow the drive to dissipate regenerative energy (normally associated with quickly decelerating a motor). Proper application of the brake chopper is defined in chapter [Resistor braking](#). This can be applied to a single drive or multiple drives with DC bus connected to allow a sharing of regenerative energy.

Equipment warranty and liability

The manufacturer warrants the equipment supplied against defects in design, materials and workmanship for a period of twelve (12) months after installation or twenty-four (24) months from date of manufacturing, whichever first occurs. The local ABB office or distributor may grant a warranty period different to the above and refer to local terms of liability as defined in the supply contract.

The manufacturer is not responsible for

- any costs resulting from a failure if the installation, commissioning, repair, alternation, or ambient conditions of the drive do not fulfil the requirements specified in the documentation delivered with the unit and other relevant documentation.
- units subjected to misuse, negligence or accident
- units comprised of materials provided or designs stipulated by the purchaser.

In no event shall the manufacturer, its suppliers or subcontractors be liable for special, indirect, incidental or consequential damages, losses or penalties.

This is the sole and exclusive warranty given by the manufacturer with respect to the equipment and is in lieu of and excludes all other warranties, express or implied, arising by operation of law or otherwise, including, but not limited to, any implied warranties of merchantability or fitness for a particular purpose.

If you have any questions concerning your ABB drive, please contact the local distributor or ABB office. The technical data, information and specifications are valid at the time of printing. The manufacturer reserves the right to modifications without prior notice.

Dimensional drawings

Dimensional drawings of the ACS800-01 are shown below. The dimensions are given in millimetres and [inches].

Frame size R2 (IP 21, UL type 1)

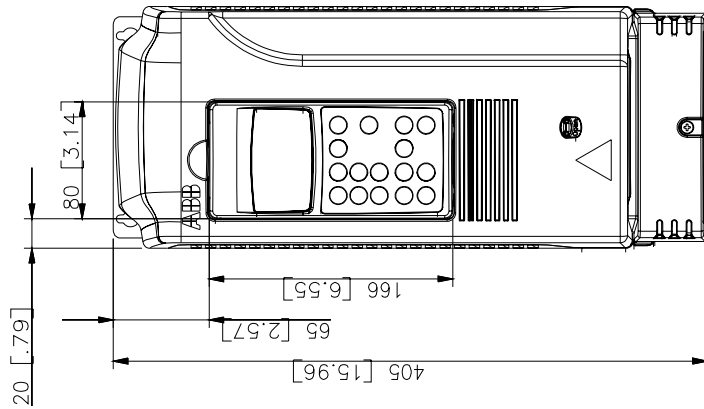
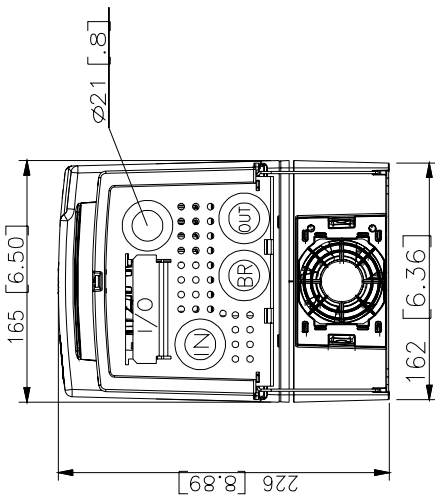
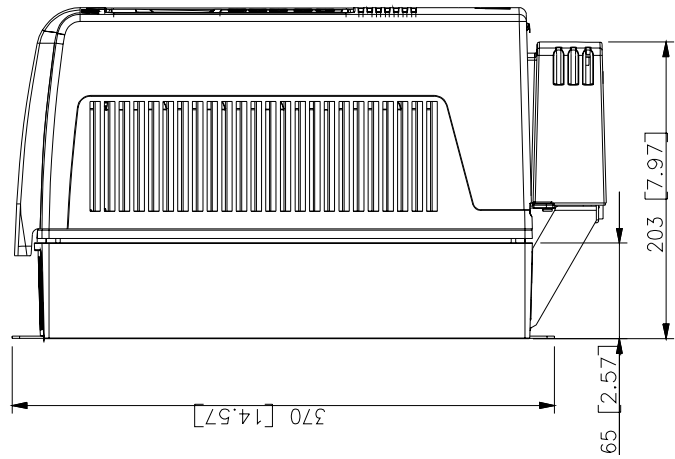
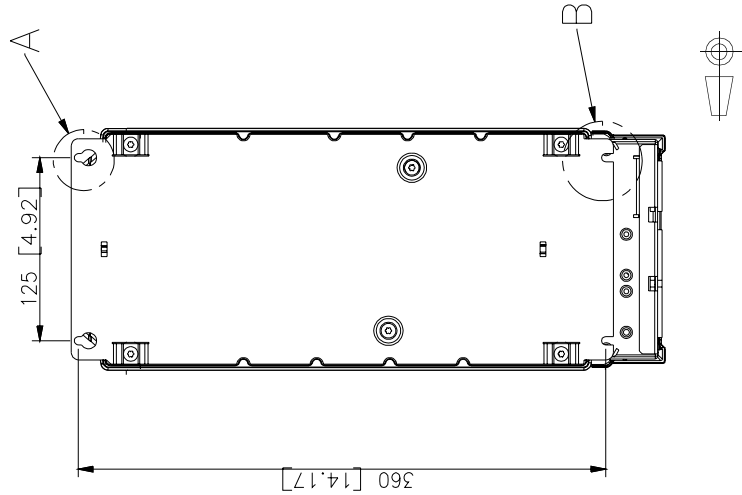
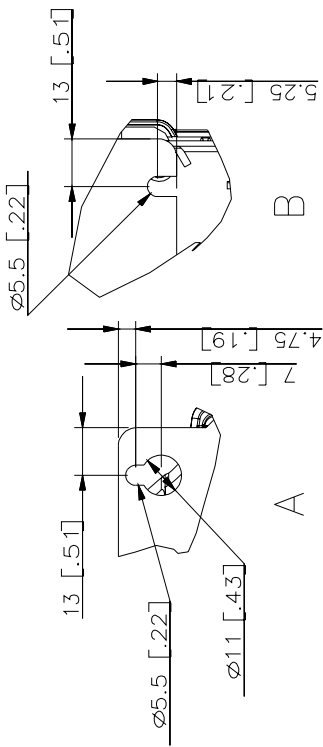

64646117-B

Frame size R2 (IP 55, UL type 12)

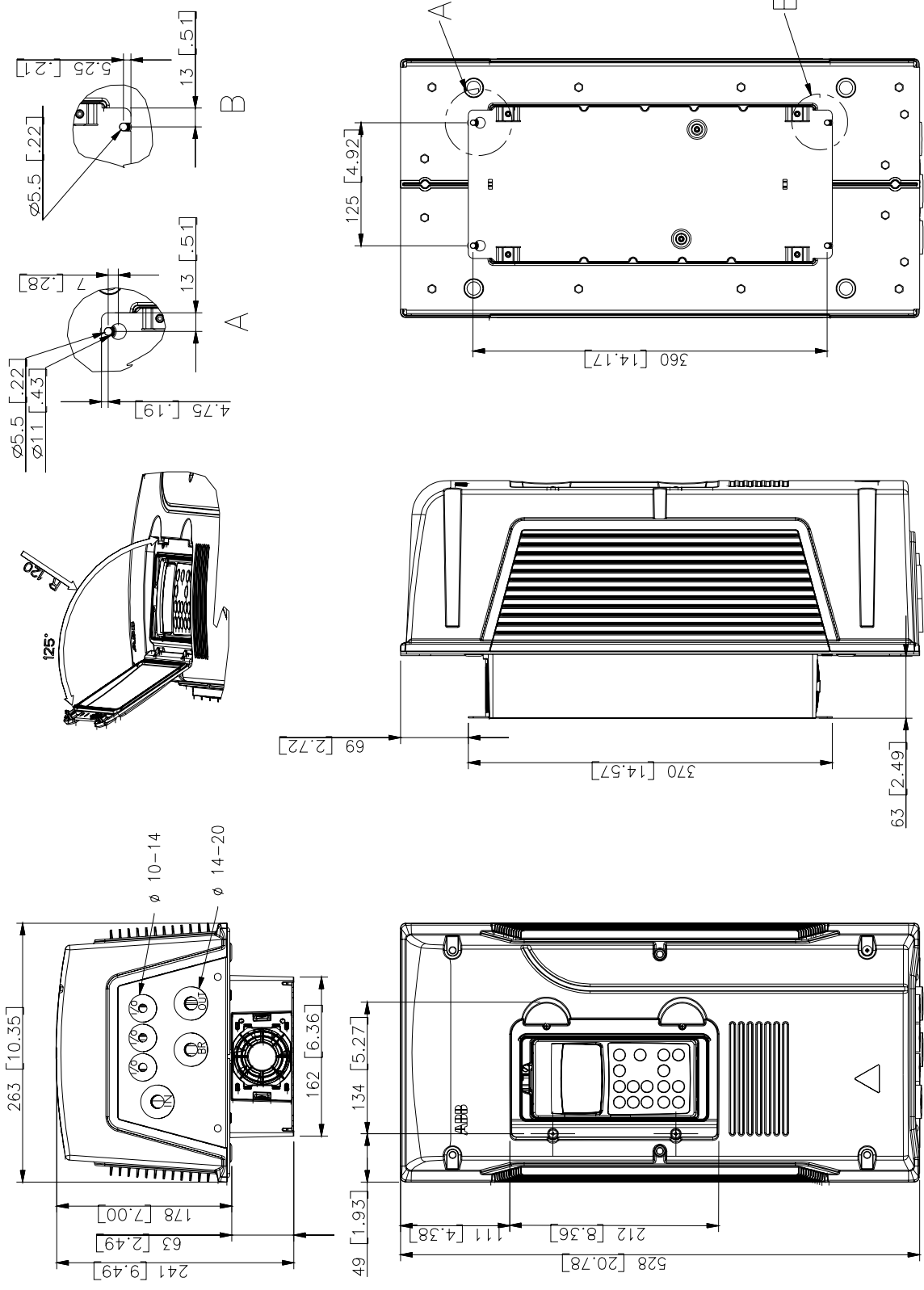

64646150-B

Frame size R3 (IP 21, UL type 1)

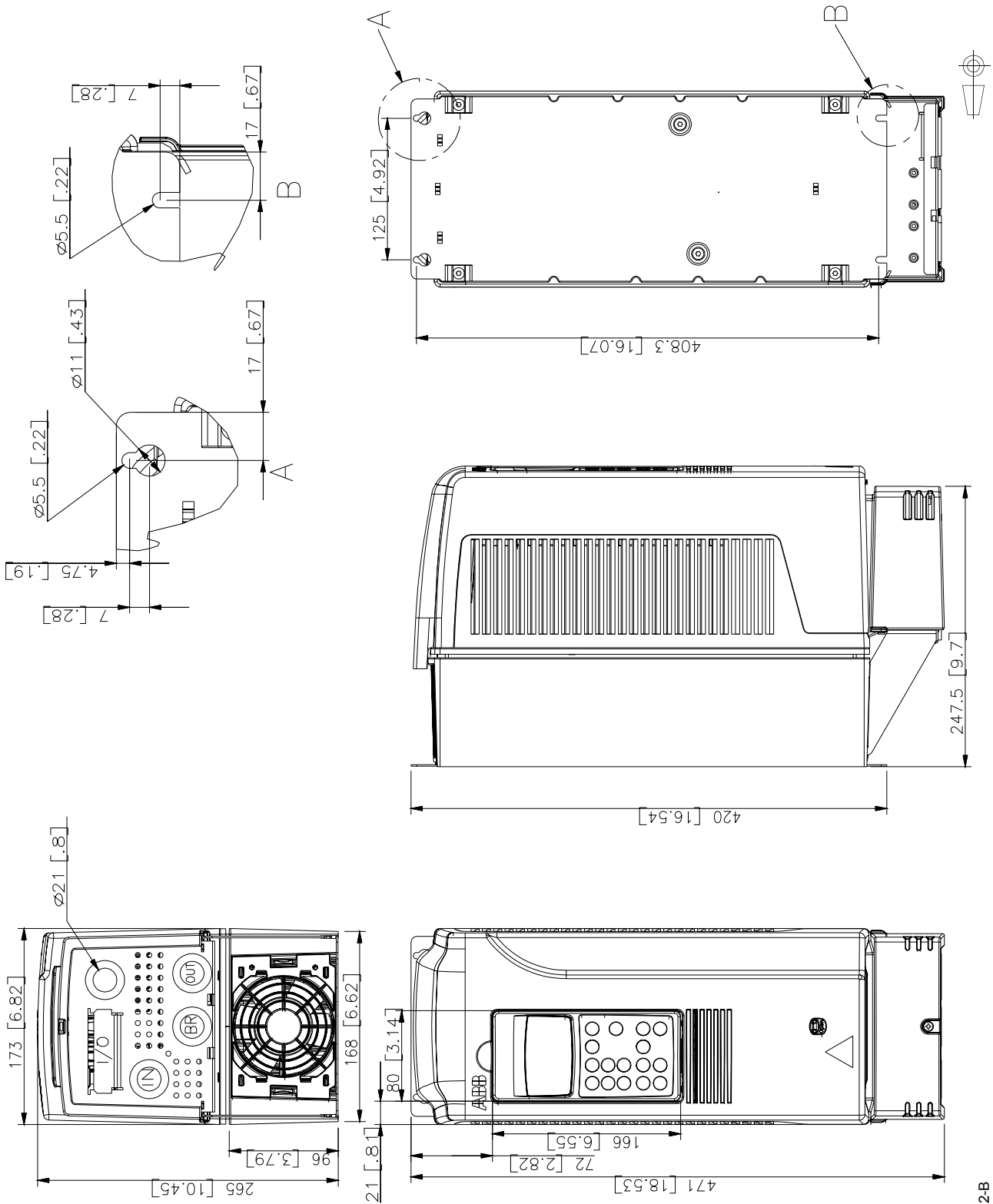

64646192-B

Frame size R3 (IP 55, UL type 12)

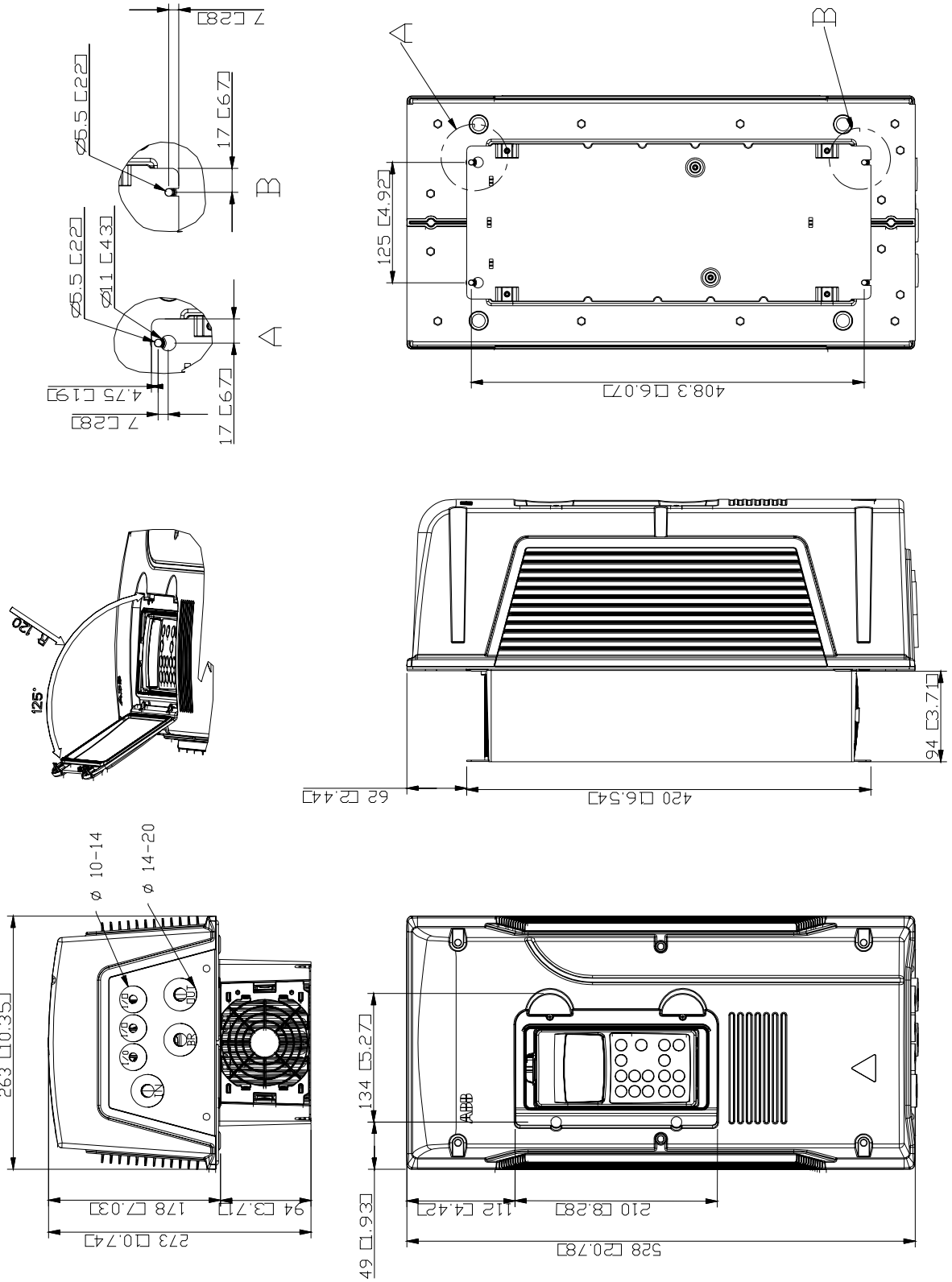

64646206-C

Frame size R4 (IP 21, UL type 1)

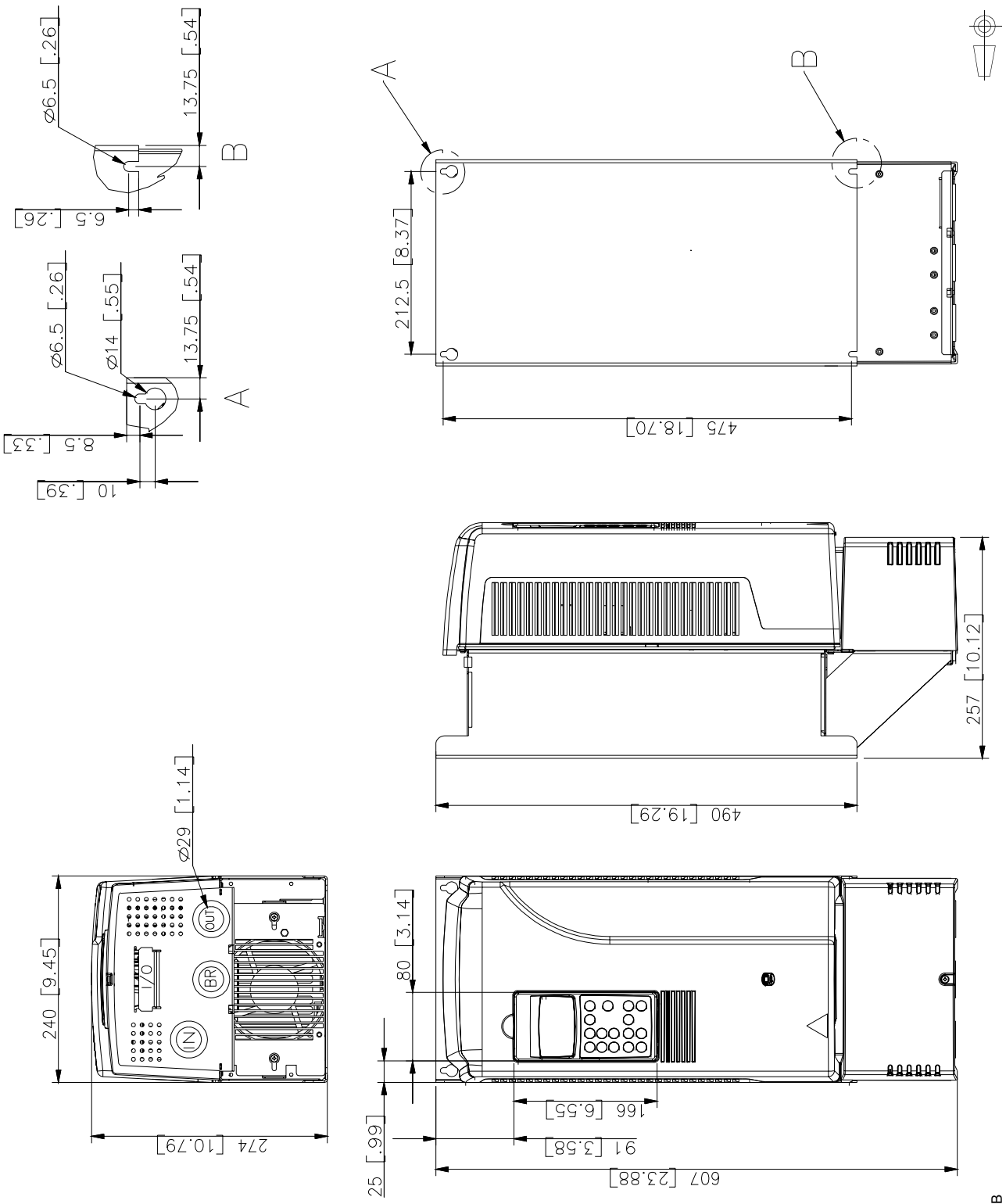

64646214-B

Frame size R4 (IP 55, UL type 12)

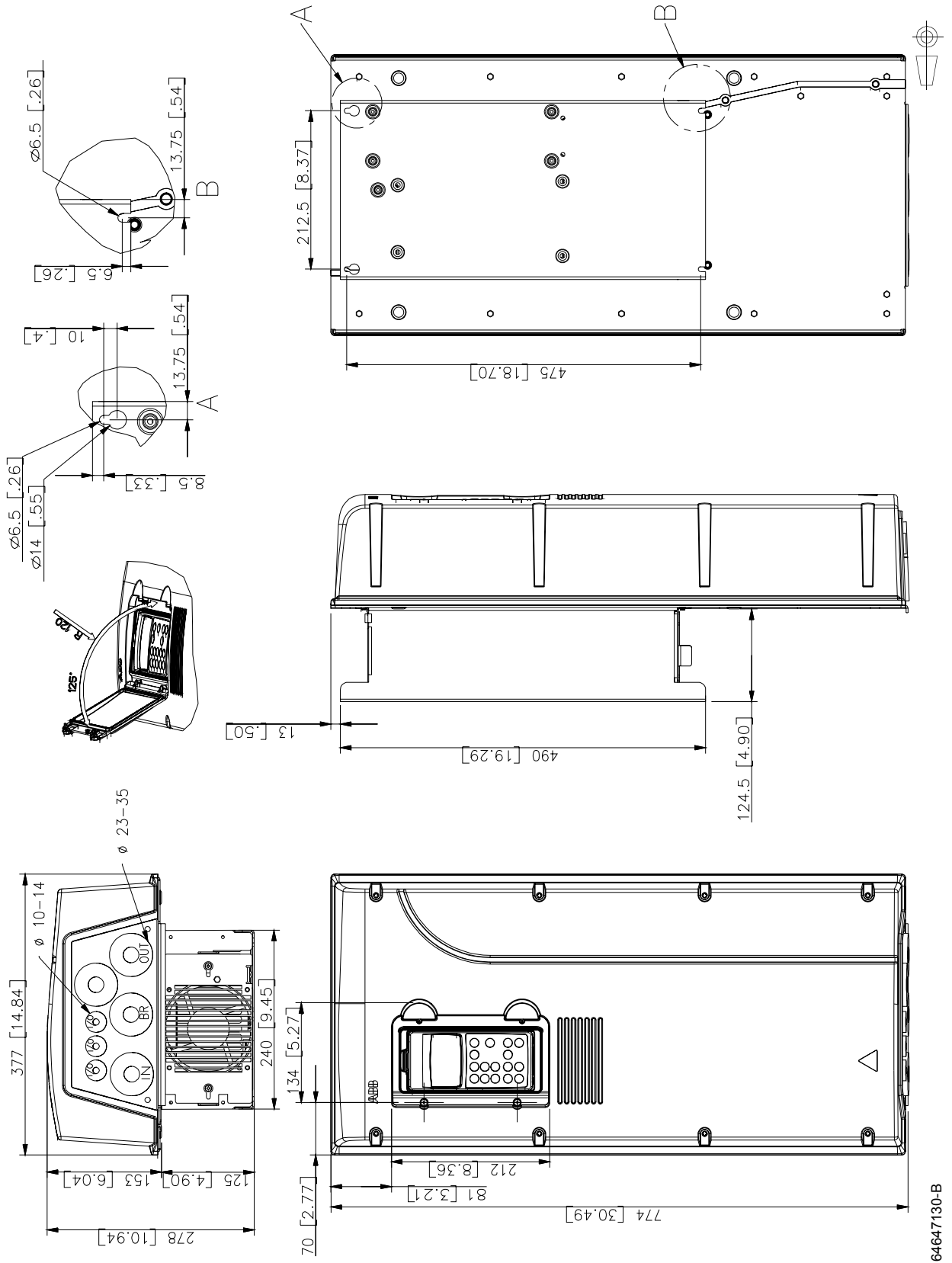

64647130-B

Frame size R5 (IP 55, UL type 12)

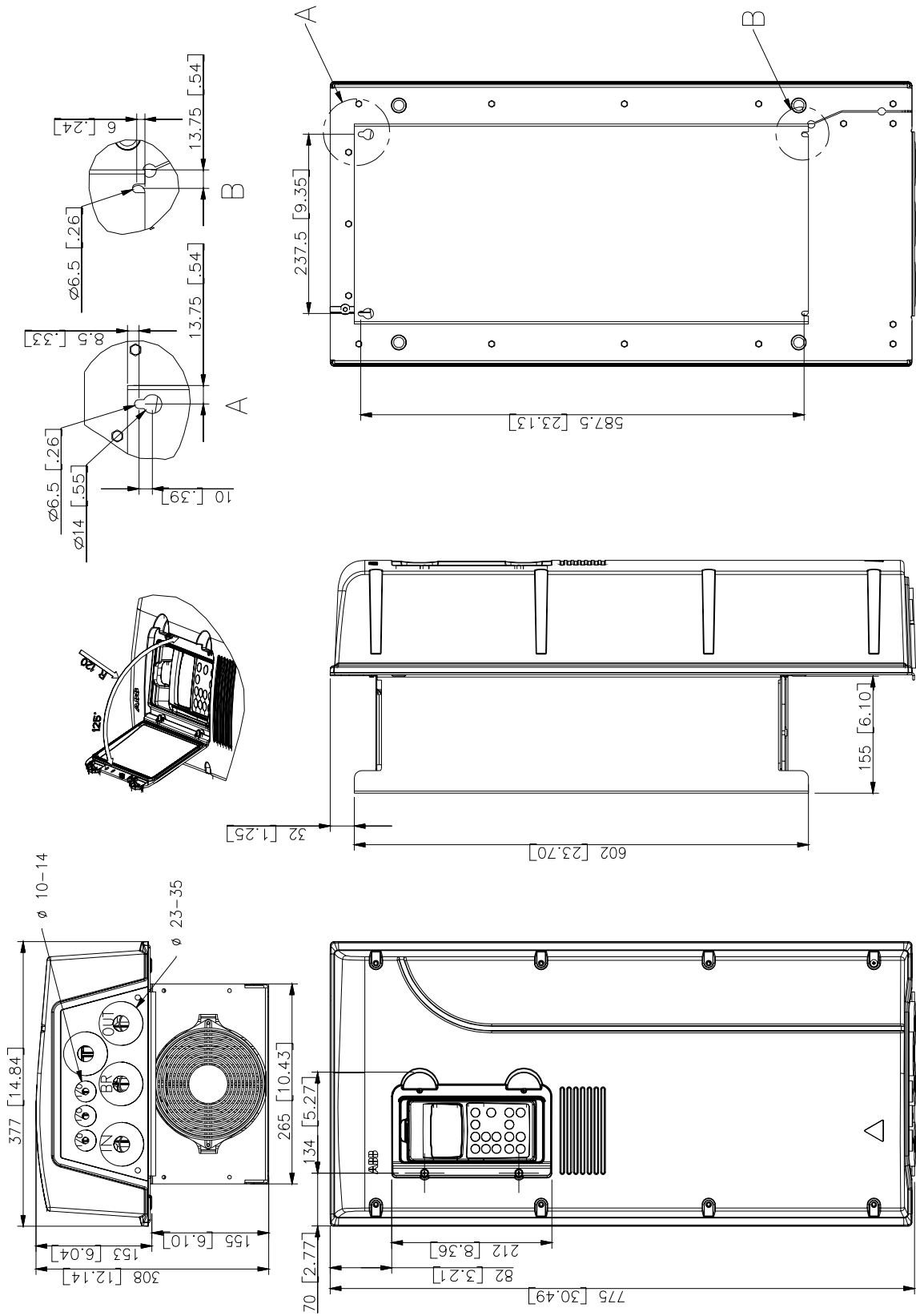

64647156-B

Frame size R6 (IP 21, UL type 1)

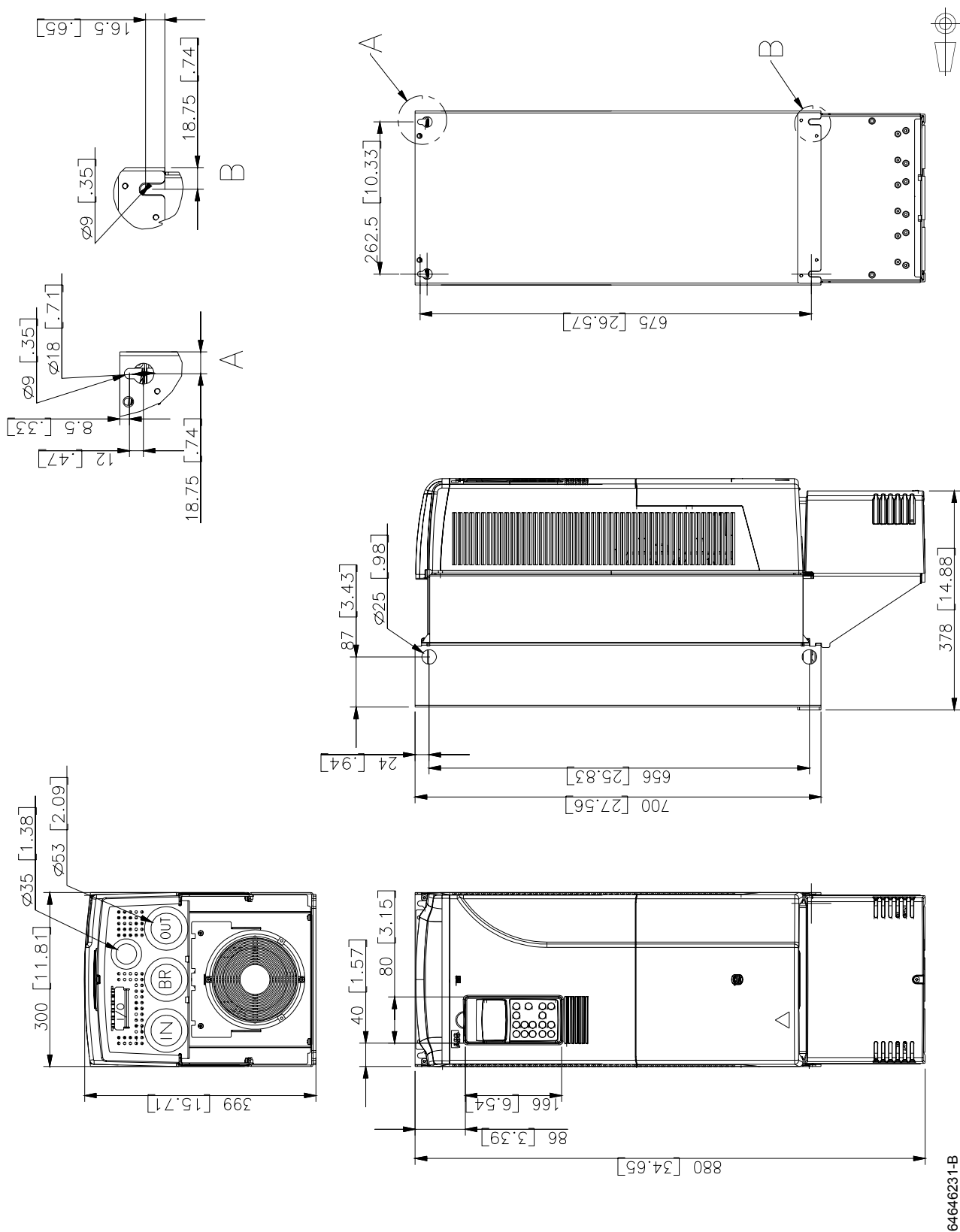

Frame size R6 (IP 55, UL type 12)

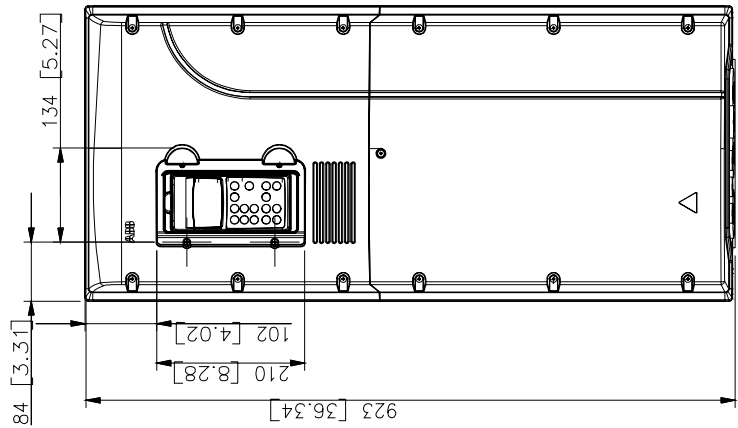
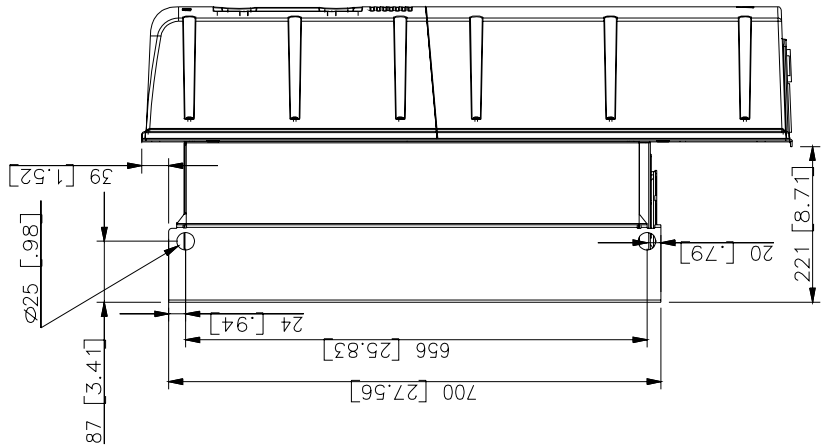
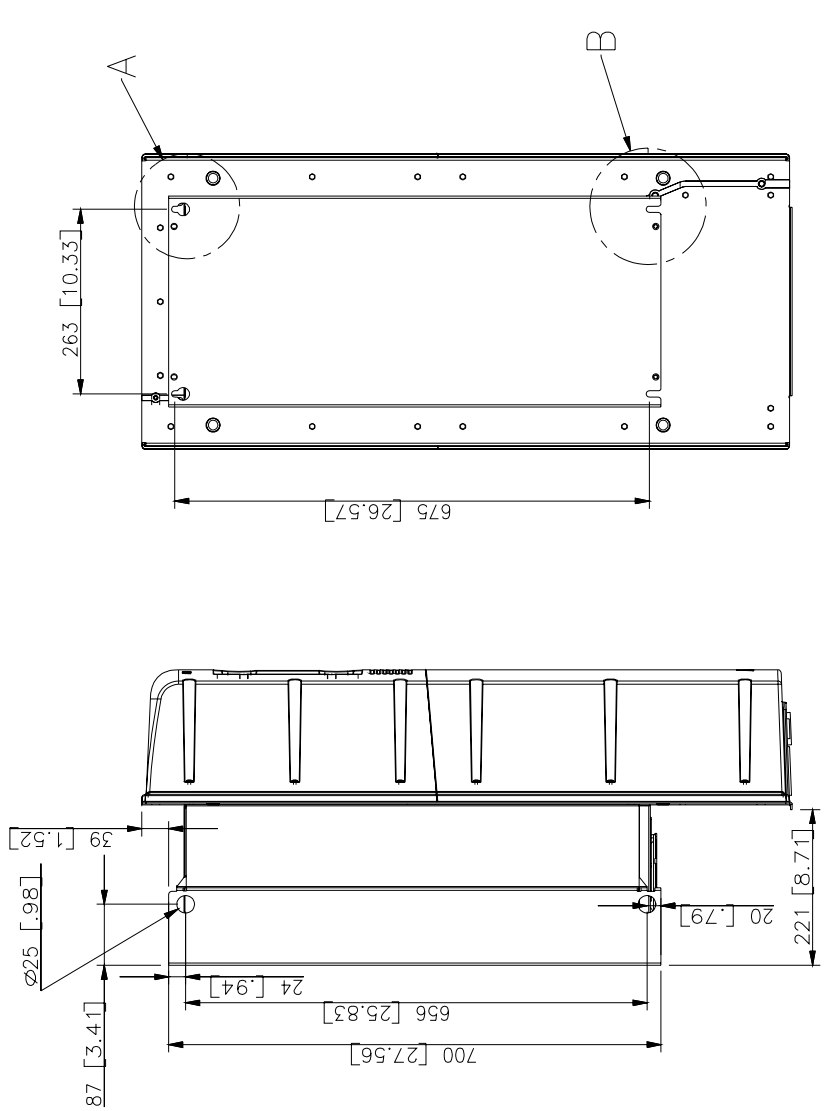
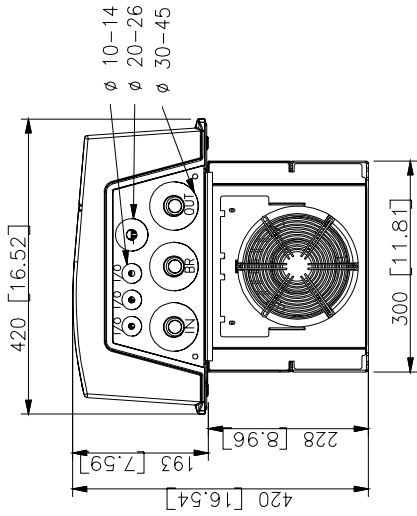
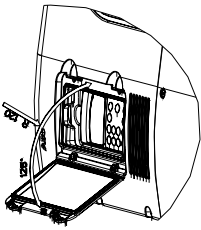
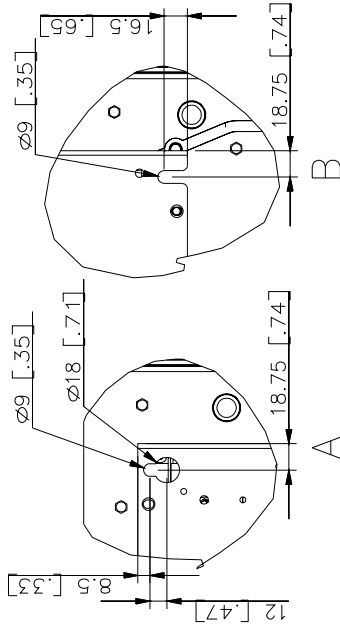

64684957-C

Dimensional drawings (USA)

Dimensional drawings of the ACS800-U1 are shown below. The dimensions are given in millimetres and [inches].

Frame size R2 (UL type 1, IP 21)

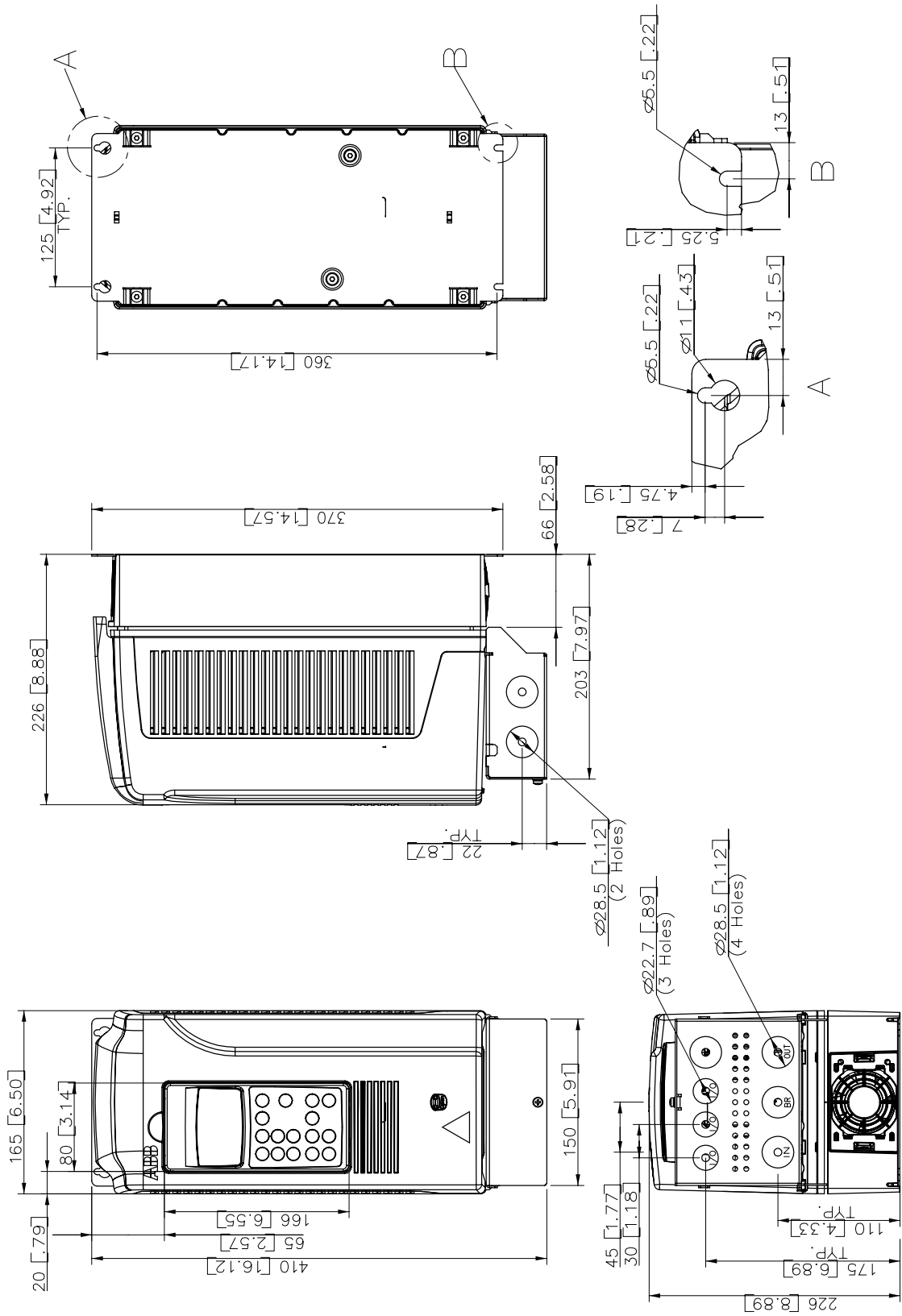

Frame size R2 (UL type 12, IP 55)

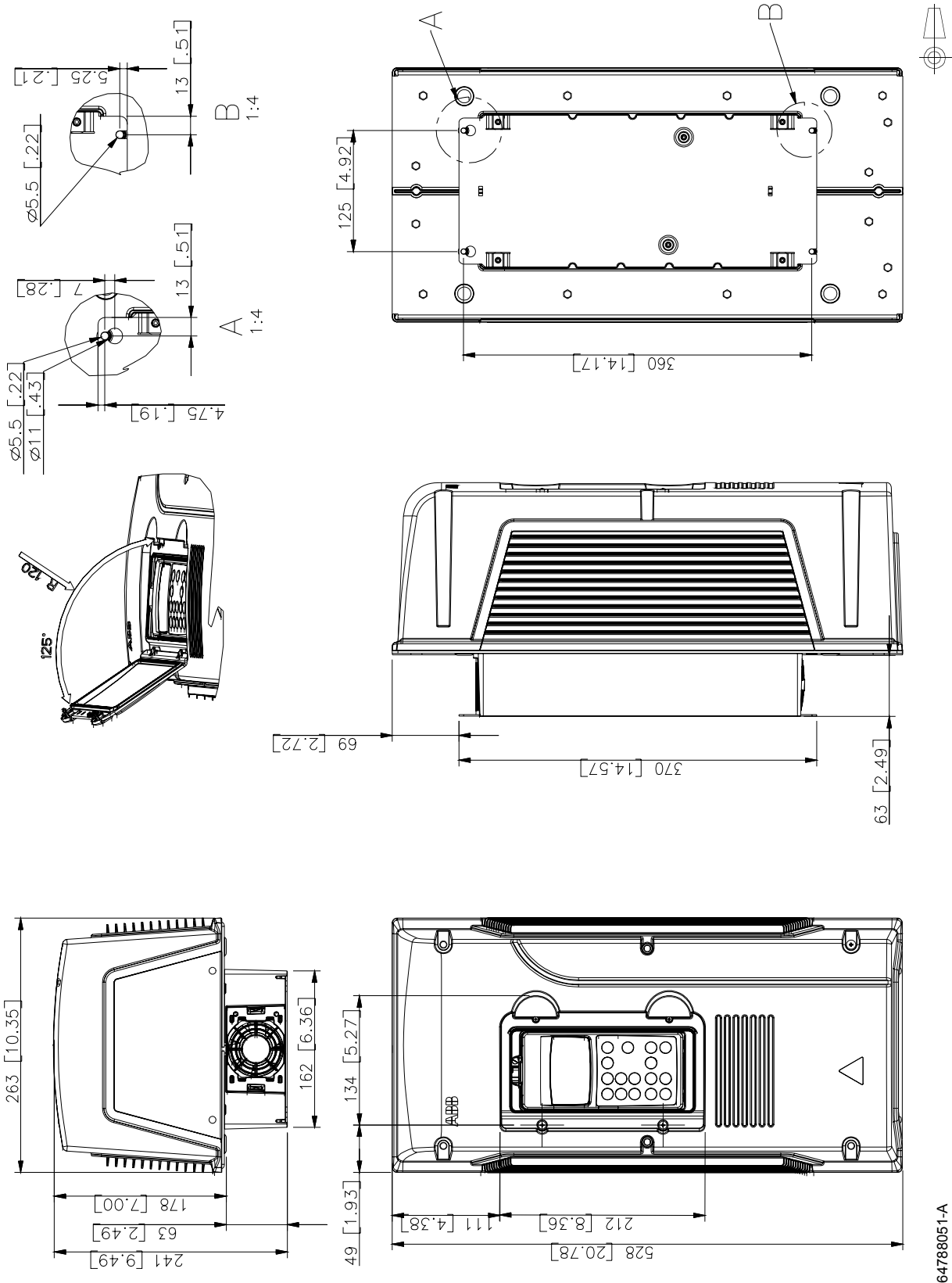

64788051-A

Frame size R3 (UL type 1, IP 21)

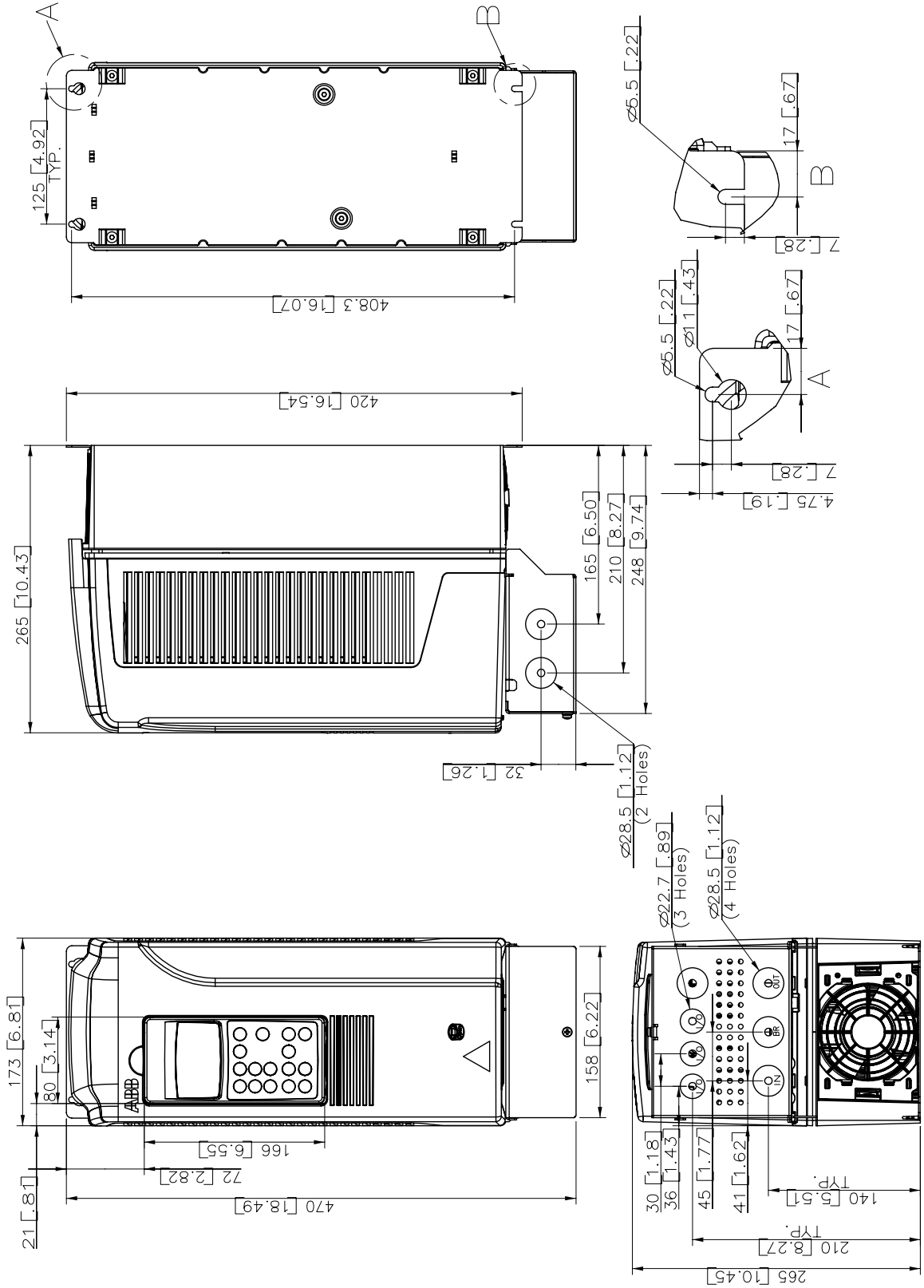

64741811-A

Frame size R3 (UL type 12, IP 55)

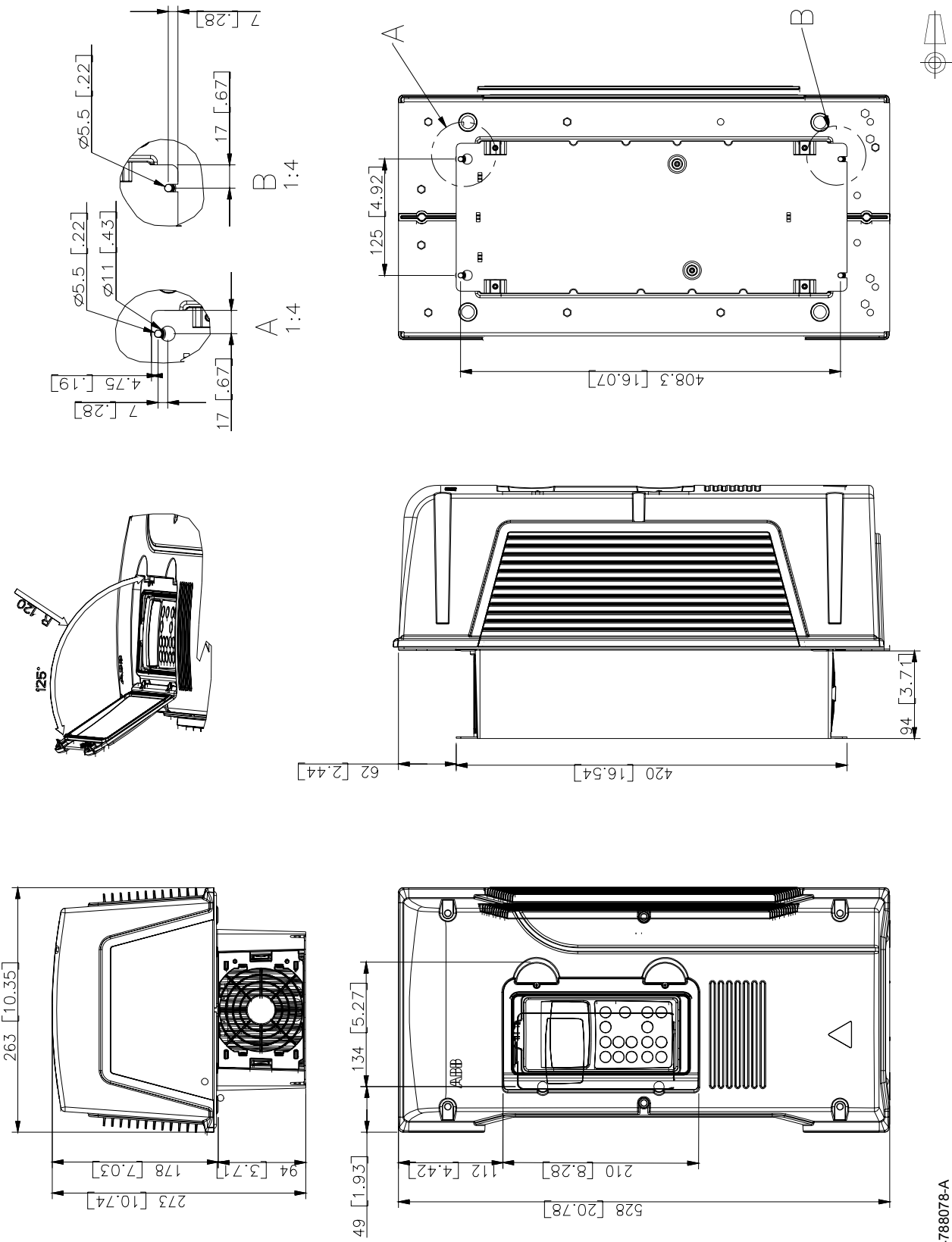

6478078-A

Frame size R4 (UL type 1, IP 21)

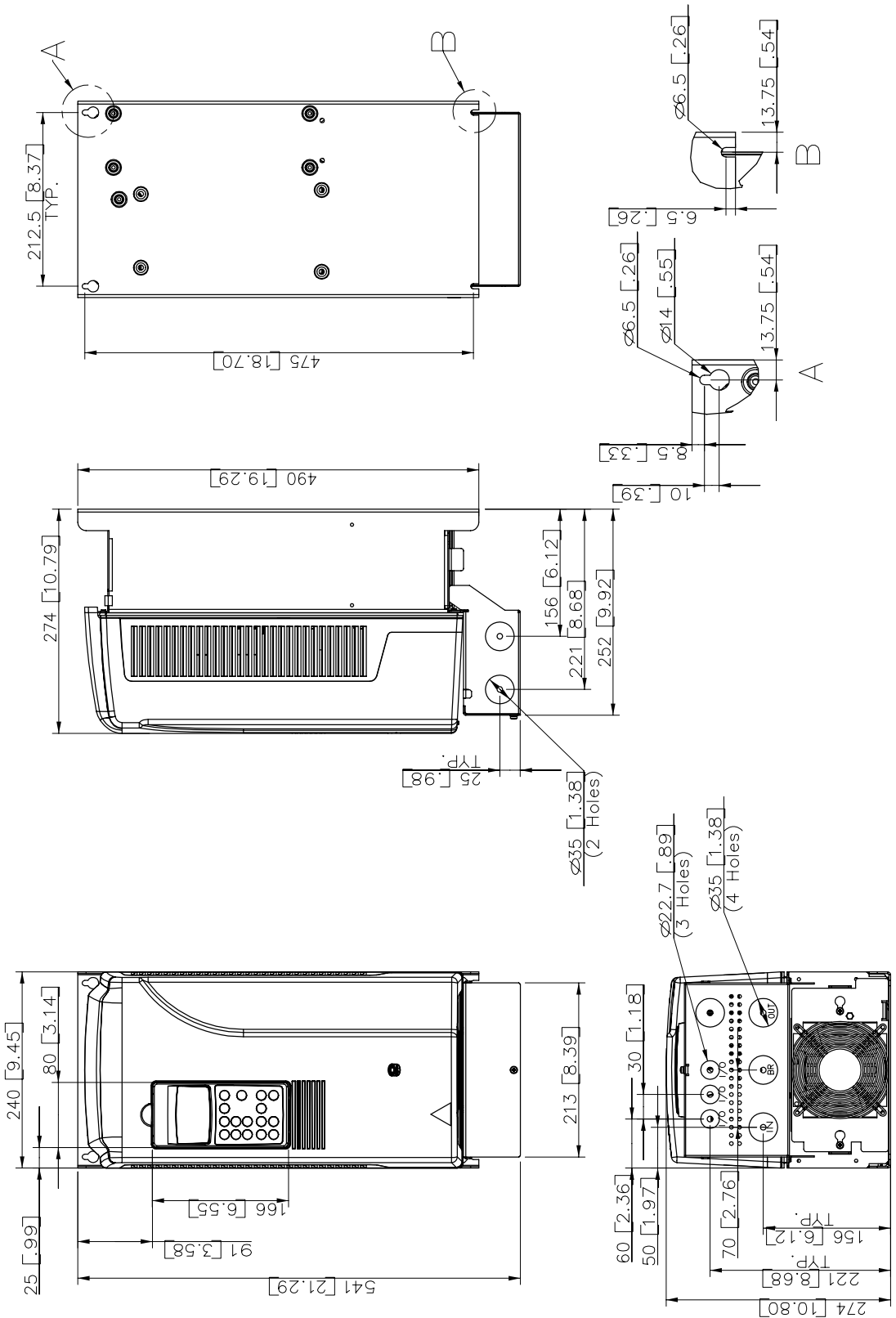

64741802-A

Frame size R4 (UL type 12, IP 55)

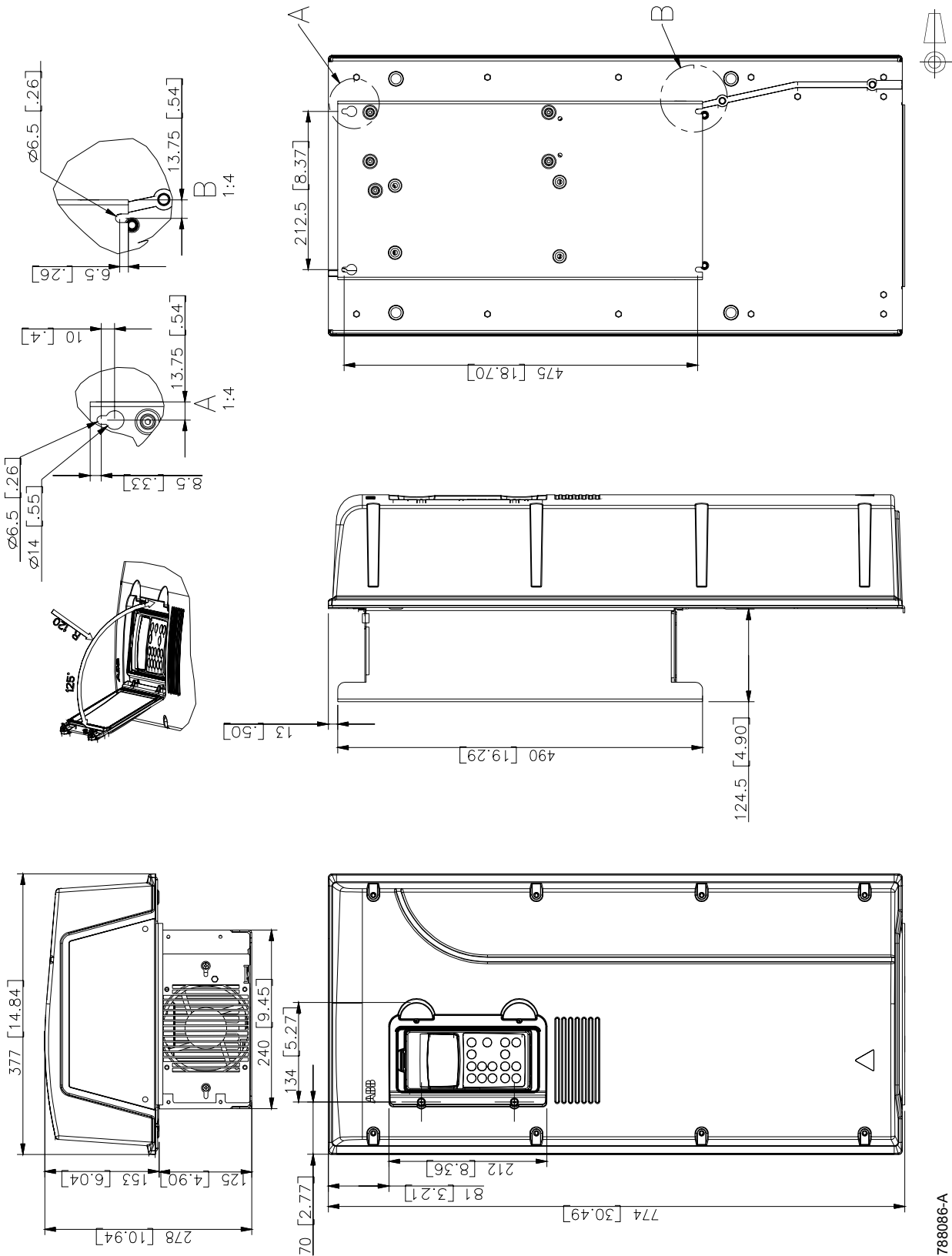

64788086-A

Frame size R5 (UL type 1, IP 21)

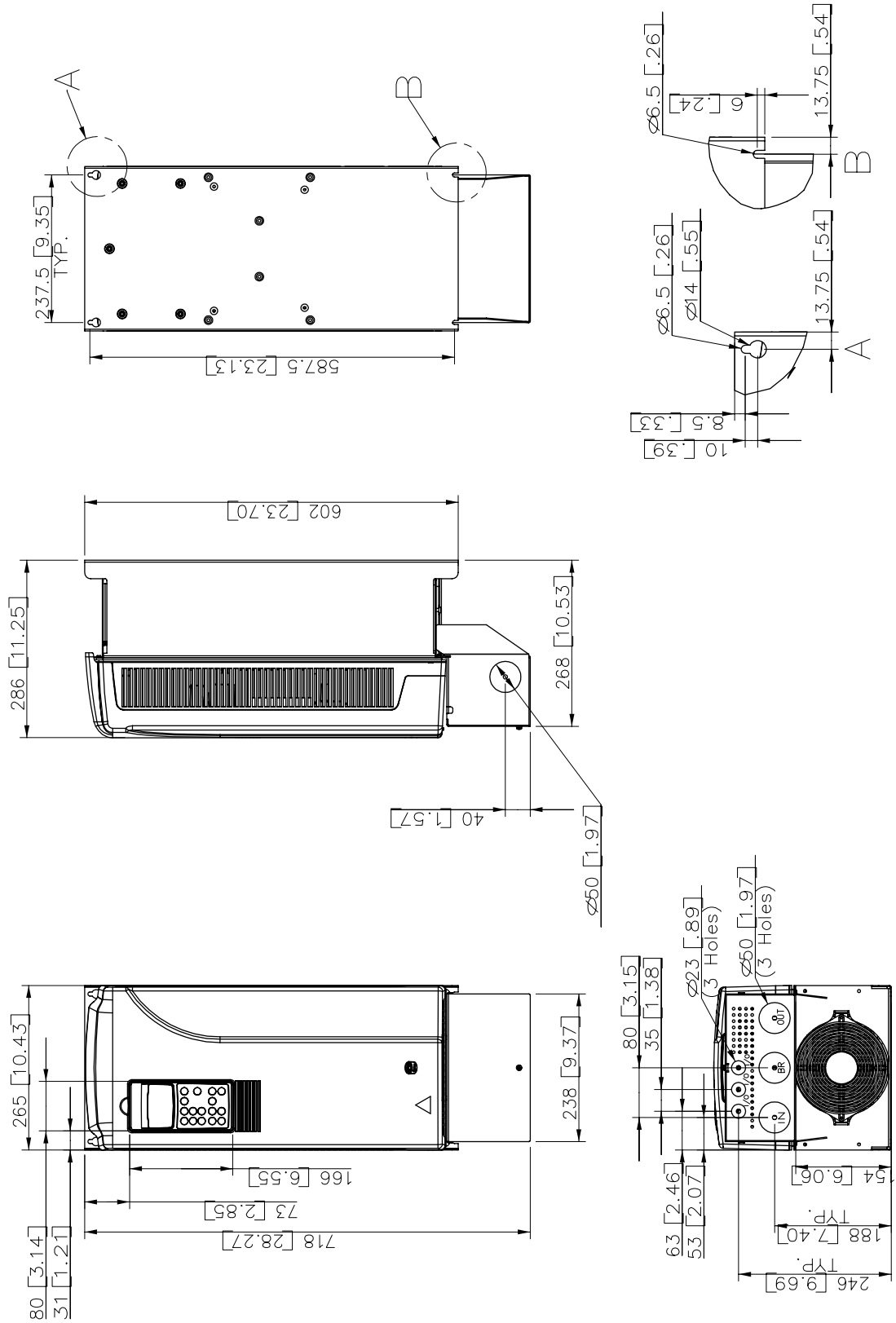

64741748-A

Frame size R5 (UL type 12, IP 55)

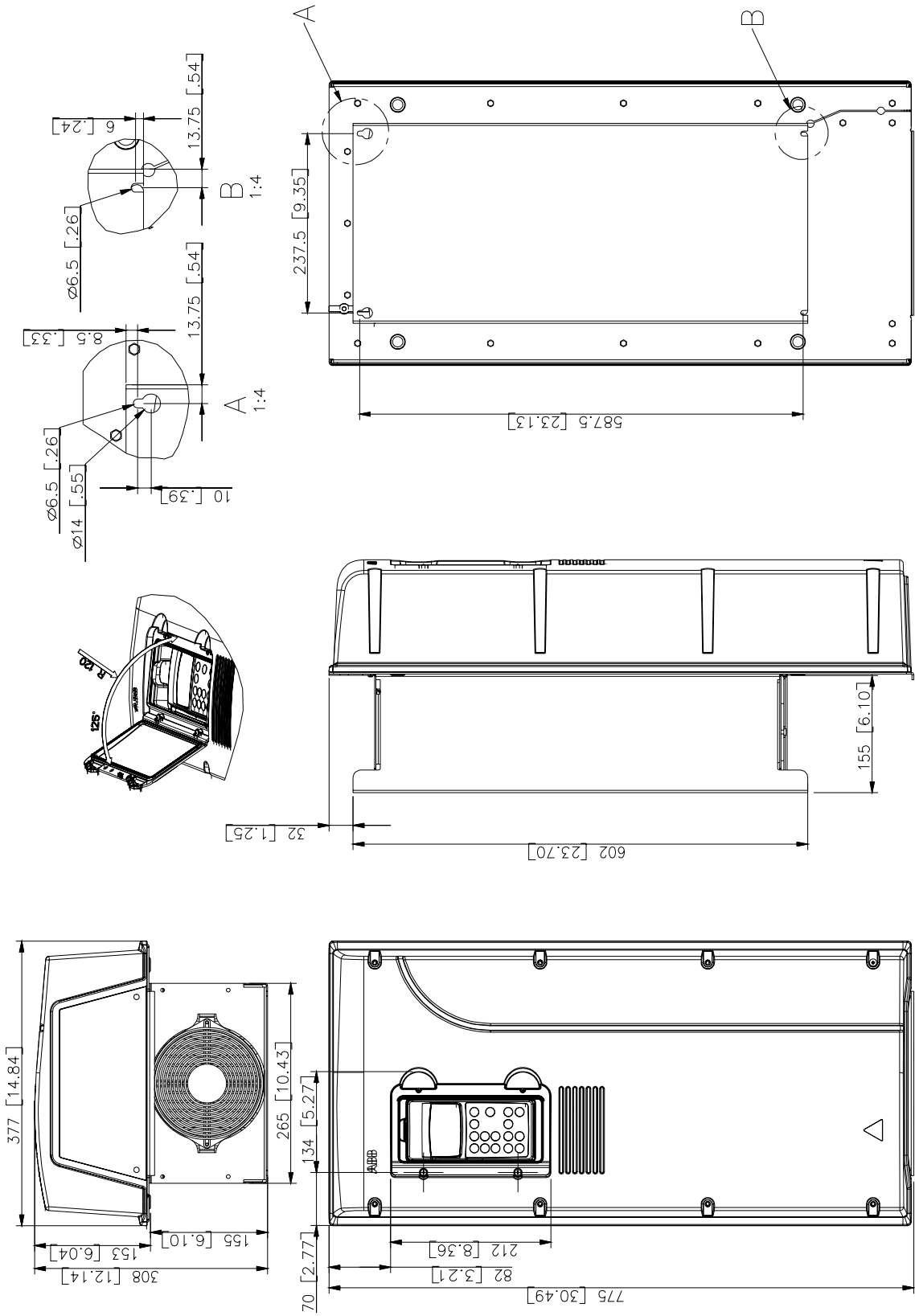

64788094-A

Frame size R6 (UL type 1, IP 21)

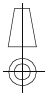
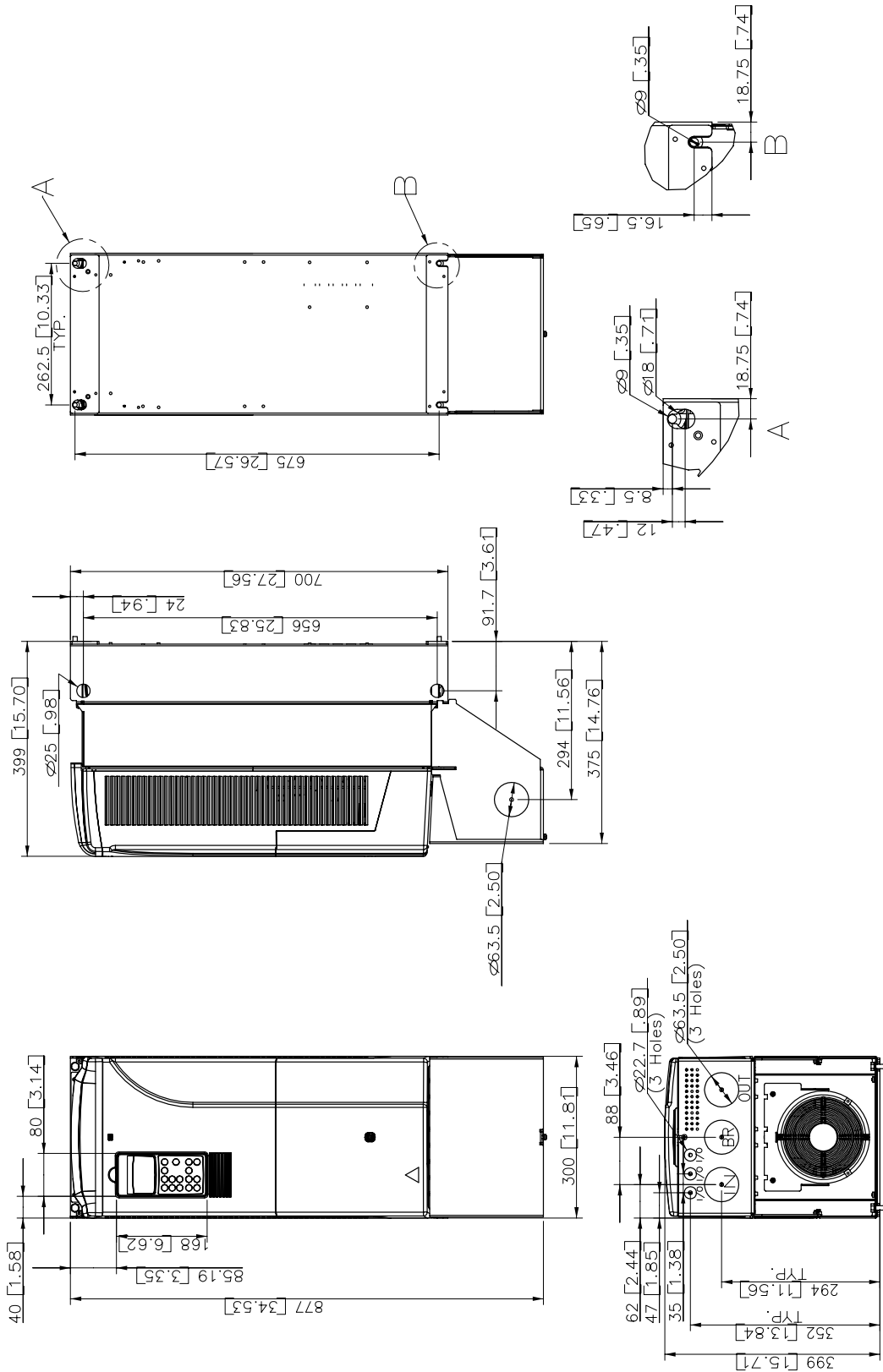

64739361-A

Frame size R6 (UL type 12, IP 55)

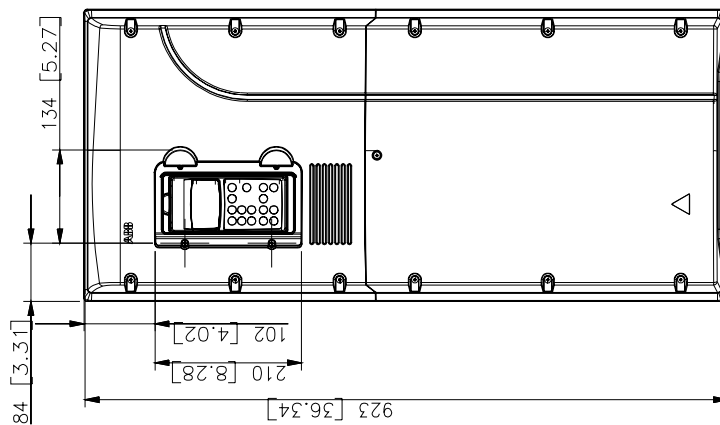
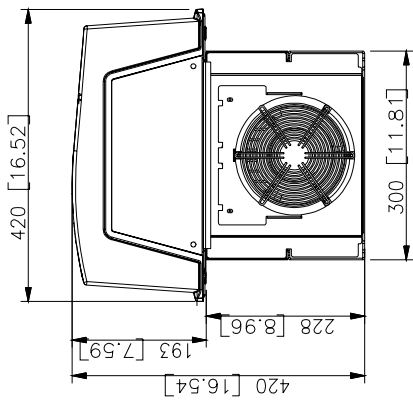
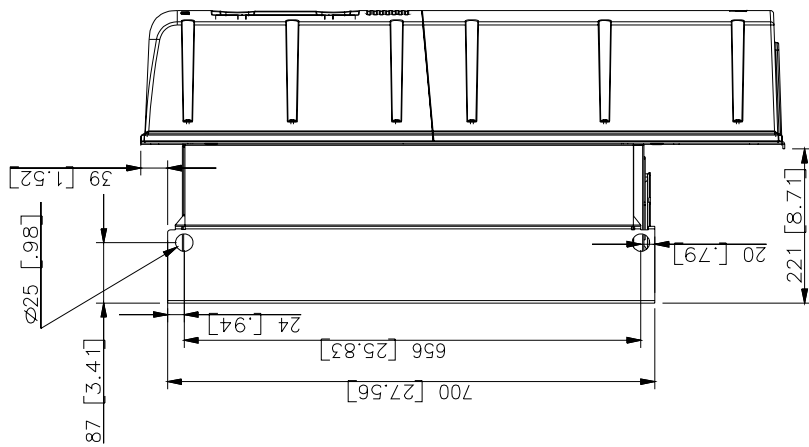
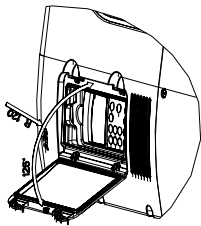
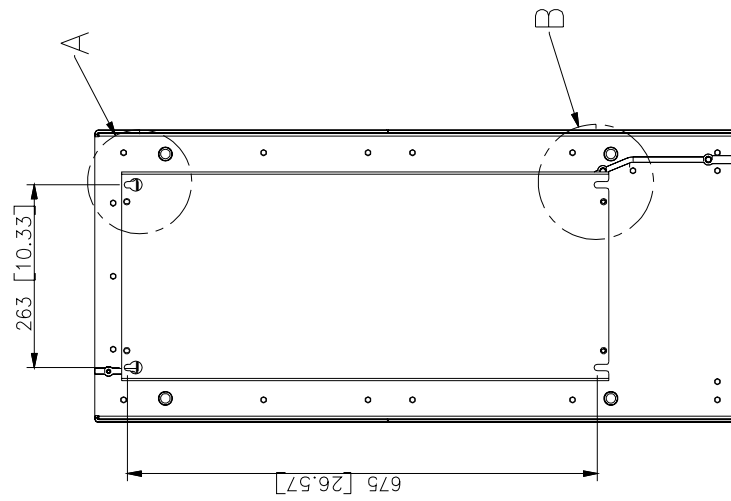
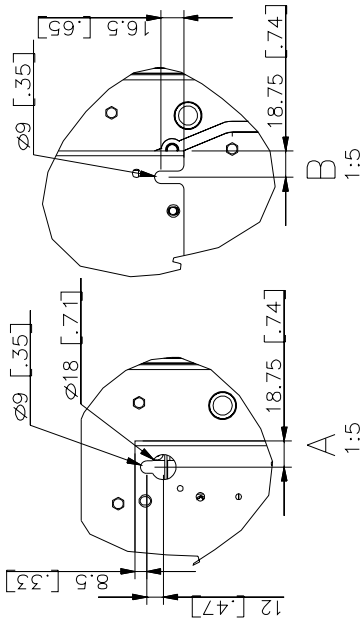

64788108-A

Resistor braking

What this chapter contains

This chapter describes how to select, protect and wire brake choppers and resistors. The chapter also contains the technical data.

To which products this chapter applies

This chapter applies to the ACS800-01/U1 (frame sizes R2 to R6), ACS800-02/U2 (frame sizes R7 and R8), ACS800-04/U4 (frame sizes R7 and R8) and ACS800-07/U7 (frame sizes R6, R7 and R8).

Availability of brake choppers and resistors for the ACS800

Frame R2 and R3 drives and 690 V units of frame size R4 have a built-in brake chopper as standard equipment. For other units, brake choppers are optionally available as built-in units, indicated in the type code by +D150.

Resistors are available as add-on kits. For the ACS800-07/U7, resistors are available as factory installed.

How to select the correct drive/chopper/resistor combination

1. Calculate the maximum power (P_{\max}) generated by the motor during braking.
2. Select a suitable drive / brake chopper / brake resistor combination for the application according to the following tables (take account of other factors in the drive selection also). The following condition must be met:

$$P_{\text{br}} \geq P_{\max}$$

where

P_{br} denotes $P_{\text{br}5}$, $P_{\text{br}10}$, $P_{\text{br}30}$, $P_{\text{br}60}$, or P_{brcont} depending on the duty cycle.

3. Check the resistor selection. The energy generated by the motor during a 400-second period must not exceed the resistor heat dissipation capacity E_R .

If the E_R value is not sufficient, it is possible to use a four-resistor assembly in which two standard resistors are connected in parallel, two in series. The E_R value of the four-resistor assembly is four times the value specified for the standard resistor.

Note: A resistor other than the standard resistor can be used provided that:

- its resistance is not lower than the resistance of the standard resistor.



WARNING! Never use a brake resistor with a resistance below the value specified for the particular drive / brake chopper / resistor combination. The drive and the chopper are not able to handle the overcurrent caused by the low resistance.

- the resistance does not restrict the braking capacity needed, i.e.,

$$P_{\max} < \frac{U_{\text{DC}}^2}{R}$$

where

P_{\max} maximum power generated by the motor during braking

U_{DC} voltage over the resistor during braking, e.g.,

1.35 · 1.2 · 415 VDC (when supply voltage is 380 to 415 VAC),

1.35 · 1.2 · 500 VDC. (when supply voltage is 440 to 500 VAC) or

1.35 · 1.2 · 690 VDC (when supply voltage is 525 to 690 VAC).

R resistor resistance (ohm)

- the heat dissipation capacity (E_R) is sufficient for the application (see step 3 above).

Optional brake chopper and resistor(s) for the ACS800-01/U1

The nominal ratings for dimensioning the brake resistors for the ACS800-01 and ACS800-U1 are given below at an ambient temperature of 40 °C (104 °F).

ACS 800-01 type ACS 800-U1 type	Braking power of the chopper and the drive	Brake resistor(s)			
	P_{brcont} (kW)	Type	R (ohm)	E_R (kJ)	P_{Rcont} (kW)
230 V units					
-0001-2	0.55	SACE08RE44	44	210	1
-0002-2	0.8	SACE08RE44	44	210	1
-0003-2	1.1	SACE08RE44	44	210	1
-0004-2	1.5	SACE08RE44	44	210	1
-0005-2	2.2	SACE15RE22	22	420	2
-0006-2	3.0	SACE15RE22	22	420	2
-0009-2	4.0	SACE15RE22	22	420	2
-0011-2	5.5	SACE15RE13	13	435	2
-0016-2	11	SAFUR90F575	8	1800	4.5
-0020-2	17	SAFUR90F575	8	1800	4.5
-0025-2	23	SAFUR80F500	6	2400	6
-0030-2	28	SAFUR125F500	4	3600	9
-0040-2	33	SAFUR125F500	4	3600	9
-0050-2	45	2xSAFUR125F500	2	7200	18
-0060-2	56	2xSAFUR125F500	2	7200	18
-0070-2	68	2xSAFUR125F500	2	7200	18

ACS 800-01 type ACS 800-U1 type	Braking power of the chopper and the drive P_{brcont} (kW)	Brake resistor(s)			
		Type	R (ohm)	E_R (kJ)	P_{Rcont} (kW)
400 V units					
-0003-3	1.1	SACE08RE44	44	210	1
-0004-3	1.5	SACE08RE44	44	210	1
-0005-3	2.2	SACE08RE44	44	210	1
-0006-3	3.0	SACE08RE44	44	210	1
-0009-3	4.0	SACE08RE44	44	210	1
-0011-3	5.5	SACE15RE22	22	420	2
-0016-3	7.5	SACE15RE22	22	420	2
-0020-3	11	SACE15RE22	22	420	2
-0025-3	23	SACE15RE13	13	435	2
-0030-3	28	SACE15RE13	13	435	2
-0040-3	33	SAFUR90F575	8	1800	4.5
-0050-3	45	SAFUR90F575	8	1800	4.5
-0060-3	56	SAFUR90F575	8	1800	4.5
-0070-3	68	SAFUR80F500	6	2400	6
-0100-3	83	SAFUR125F500	4	3600	9
-0120-3	113	SAFUR125F500	4	3600	9
500 V units					
-0004-5	1.5	SACE08RE44	44	210	1
-0005-5	2.2	SACE08RE44	44	210	1
-0006-5	3.0	SACE08RE44	44	210	1
-0009-5	4.0	SACE08RE44	44	210	1
-0011-5	5.5	SACE08RE44	44	210	1
-0016-5	7.5	SACE15RE22	22	420	2
-0020-5	11	SACE15RE22	22	420	2
-0025-5	15	SACE15RE22	22	420	2
-0030-5	28	SACE15RE13	13	435	2
-0040-5	33	SACE15RE13	13	435	2
-0050-5	45	SAFUR90F575	8	1800	4.5
-0060-5	56	SAFUR90F575	8	1800	4.5
-0070-5	68	SAFUR90F575	8	1800	4.5
-0100-5	83	SAFUR125F500	4	3600	9
-0120-5	113	SAFUR125F500	4	3600	9
-0140-5	135	SAFUR125F500	4	3600	9
690 V units					
-0011-7	8	SACE08RE44	44	210	1
-0016-7	11	SACE08RE44	44	210	1
-0020-7	16	SACE08RE44	44	210	1
-0025-7	22	SACE08RE44	44	210	1
-0030-7	28	SACE15RE22	22	420	2
-0040-7	22/33 ¹⁾	SACE15RE22	22	420	2
-0050-7	45	SACE15RE13	13	435	2
-0060-7	56	SACE15RE13	13	435	2
-0070-7	68	SAFUR90F575	8	1800	4.5
-0100-7	83	SAFUR90F575	8	1800	4.5
-0120-7	113	SAFUR80F500	6	2400	6

PDM code 00096931-H

P_{brcont} The drive and the chopper will withstand this continuous braking power. The braking is considered continuous if the braking time exceeds 30 s.

Note: Check that the braking energy transmitted to the specified resistor(s) in 400 seconds does not exceed E_R .

R Resistance value for the listed resistor assembly. **Note:** This is also the minimum allowed resistance for the brake resistor.

E_R Short energy pulse that the resistor assembly withstands every 400 seconds. This energy will heat the resistor element from 40 °C (104 °F) to the maximum allowable temperature.

P_{Rcont} Continuous power (heat) dissipation of the resistor when placed correctly. Energy E_R dissipates in 400 seconds.

¹⁾ 22 kW with standard 22 ohm resistor and 33 kW with 32...37 ohm resistor

All braking resistors must be installed outside the converter module. The SACE brake resistors are built in an IP 21 metal housing. The SAFUR brake resistors are built in an IP 00 metal frame. **Note:** The SACE and SAFUR resistors are not UL listed

Optional brake chopper and resistor(s) for the ACS800-02/U2, ACS800-04/04M/U4 and ACS800-07/U7

The nominal ratings for dimensioning the brake resistors for the ACS800-02/U2, ACS800-04/04M/U4 and ACS800-07/U7 are given below at an ambient temperature of 40 °C (104 °F).

ACS 800 type	Frame size	Braking power of the chopper and the drive				Brake resistor(s)			
		5/60 s P_{br5} (kW)	10/60 s P_{br10} (kW)	30/60 s P_{br30} (kW)	P_{brcont} (kW)	Type	R (ohm)	E_R (kJ)	P_{Rcont} (kW)
230 V units									
-0080-2	R7	68	68	68	54	SAFUR160F380	1.78	3600	9
-0100-2	R7	83	83	83	54	SAFUR160F380	1.78	3600	9
-0120-2	R7	105	67	60	40	2xSAFUR200F500	1.35	10800	27
-0140-2	R8	135	135	135	84	2xSAFUR160F380	0.89	7200	18
-0170-2	R8	135	135	135	84	2xSAFUR160F380	0.89	7200	18
-0210-2	R8	165	165	165	98	2xSAFUR160F380	0.89	7200	18
-0230-2	R8	165	165	165	113	2xSAFUR160F380	0.89	7200	18
-0260-2	R8	223	170	125	64	4xSAFUR160F380	0.45	14400	36
-0300-2	R8	223	170	125	64	4xSAFUR160F380	0.45	14400	36
400 V units									
-0070-3	R6	-	-	-	68	SAFUR80F500	6	2400	6
-0100-3	R6	-	-	-	83	SAFUR125F500	4	3600	9
-0120-3	R6	-	-	-	113	SAFUR125F500	4	3600	9
-0140-3	R7	135	135	100	80	SAFUR200F500	2.70	5400	13.5
-0170-3	R7	165	150	100	80	SAFUR200F500	2.70	5400	13.5
-0210-3	R7	165	150	100	80	SAFUR200F500	2.70	5400	13.5
-0260-3	R8	240	240	240	173	2XSAFUR210F575	1.70	8400	21
-0320-3	R8	300	300	300	143	2xSAFUR200F500	1.35	10800	27
-0400-3	R8	375	375	273	130	4xSAFUR125F500	1.00	14400	36
-0440-3	R8	473	355	237	120	4xSAFUR210F575	0.85	16800	42
-0490-3	R8	500	355	237	120	4xSAFUR210F575	0.85	16800	42
500 V units									
-0100-5	R6	-	-	-	83	SAFUR125F500	4	3600	9
-0120-5	R6	-	-	-	113	SAFUR125F500	4	3600	9
-0140-5	R6	-	-	-	135	SAFUR125F500	4	3600	9
-0170-5	R7	165	132 ²⁾	120	80	SAFUR200F500	2.70	5400	13.5
-0210-5	R7	198	132 ²⁾	120	80	SAFUR200F500	2.70	5400	13.5
-0260-5	R7	198 ¹⁾	132 ²⁾	120	80	SAFUR200F500	2.70	5400	13.5
-0270-5*	R8	240	240	240	240	2xSAFUR125F500	2.00	7200	18
-0300-5*	R8	280	280	280	280	2xSAFUR125F500	2.00	7200	18
-0320-5	R8	300	300	300	300	2xSAFUR125F500	2.00	7200	18
-0400-5	R8	375	375	375	234	2XSAFUR210F575	1.70	8400	21
-0440-5	R8	473	473	450	195	2xSAFUR200F500	1.35	10800	27
-0490-5	R8	480	480	470	210	2xSAFUR200F500	1.35	10800	27
-0550-5	R8	600	400 ⁴⁾	300	170	4xSAFUR125F500	1.00	14400	36
-0610-5	R8	600 ³⁾	400 ⁴⁾	300	170	4xSAFUR125F500	1.00	14400	36

ACS 800 type	Frame size	Braking power of the chopper and the drive				Brake resistor(s)			
		5/60 s P_{br5} (kW)	10/60 s P_{br10} (kW)	30/60 s P_{br30} (kW)	P_{brcont} (kW)	Type	R (ohm)	E_R (kJ)	P_{Rcont} (kW)
690 V units									
-0070-7	R6	-	-	-	45	SAFUR90F575	8.00	1800	4.5
-0100-7	R6	-	-	-	55	SAFUR80F500	6.00	2400	6
-0120-7	R6	-	-	-	75	SAFUR80F500	6.00	2400	6
-0140-7	R7	125 ⁵⁾	110	90	75	SAFUR80F500	6.00	2400	6
-0170-7	R7	125 ⁶⁾	110	90	75	SAFUR80F500	6.00	2400	6
-0210-7	R7	125 ⁶⁾	110	90	75	SAFUR80F500	6.00	2400	6
-0260-7	R7	135 ⁷⁾	120	100	80	SAFUR80F500	6.00	2400	6
-0320-7	R8	300	300	300	260	SAFUR200F500	2.70	5400	13.5
-0400-7	R8	375	375	375	375	SAFUR200F500	2.70	5400	13.5
-0440-7	R8	430	430	430	385	SAFUR200F500	2.70	5400	13.5
-0490-7	R8	550	400	315	225	2xSAFUR125F500	2.00	7200	18
-0550-7	R8	550	400	315	225	2xSAFUR125F500	2.00	7200	18
-0610-7	R8	550	400	315	225	2xSAFUR125F500	2.00	7200	18

PDM code 00096931-G

P_{br5} Maximum braking power of the drive with the specified resistor(s). The drive and the chopper will withstand this braking power for 5 seconds per minute.

P_{br10} The drive and the chopper will withstand this braking power for 10 seconds per minute.

P_{br30} The drive and the chopper will withstand this braking power for 30 seconds per minute.

P_{brcont} The drive and the chopper will withstand this continuous braking power. The braking is considered continuous if the braking time exceeds 30 s.

Note: Check that the braking energy transmitted to the specified resistor(s) in 400 seconds does not exceed E_R .

R Resistance value for the resistor assembly. **Note:** This is also the minimum allowed resistance for the brake resistor.

E_R Short energy pulse that the resistor assembly withstands every 400 seconds. This energy will heat the resistor element from 40 °C (104 °F) to the maximum allowable temperature.

P_{Rcont} Continuous power (heat) dissipation of the resistor when placed correctly. Energy E_R dissipates in 400 seconds.

* ACS800-Ux types only

- 1) 240 kW possible if ambient temperature is below 33 °C (91 °F)
- 2) 160 kW possible if ambient temperature is below 33 °C (91 °F)
- 3) 630 kW possible if ambient temperature is below 33 °C (91 °F)
- 4) 450 kW possible if ambient temperature is below 33 °C (91 °F)
- 5) 135 kW possible if ambient temperature is below 33 °C (91 °F)
- 6) 148 kW possible if ambient temperature is below 33 °C (91 °F)
- 7) 160 kW possible if ambient temperature is below 33 °C (91 °F)

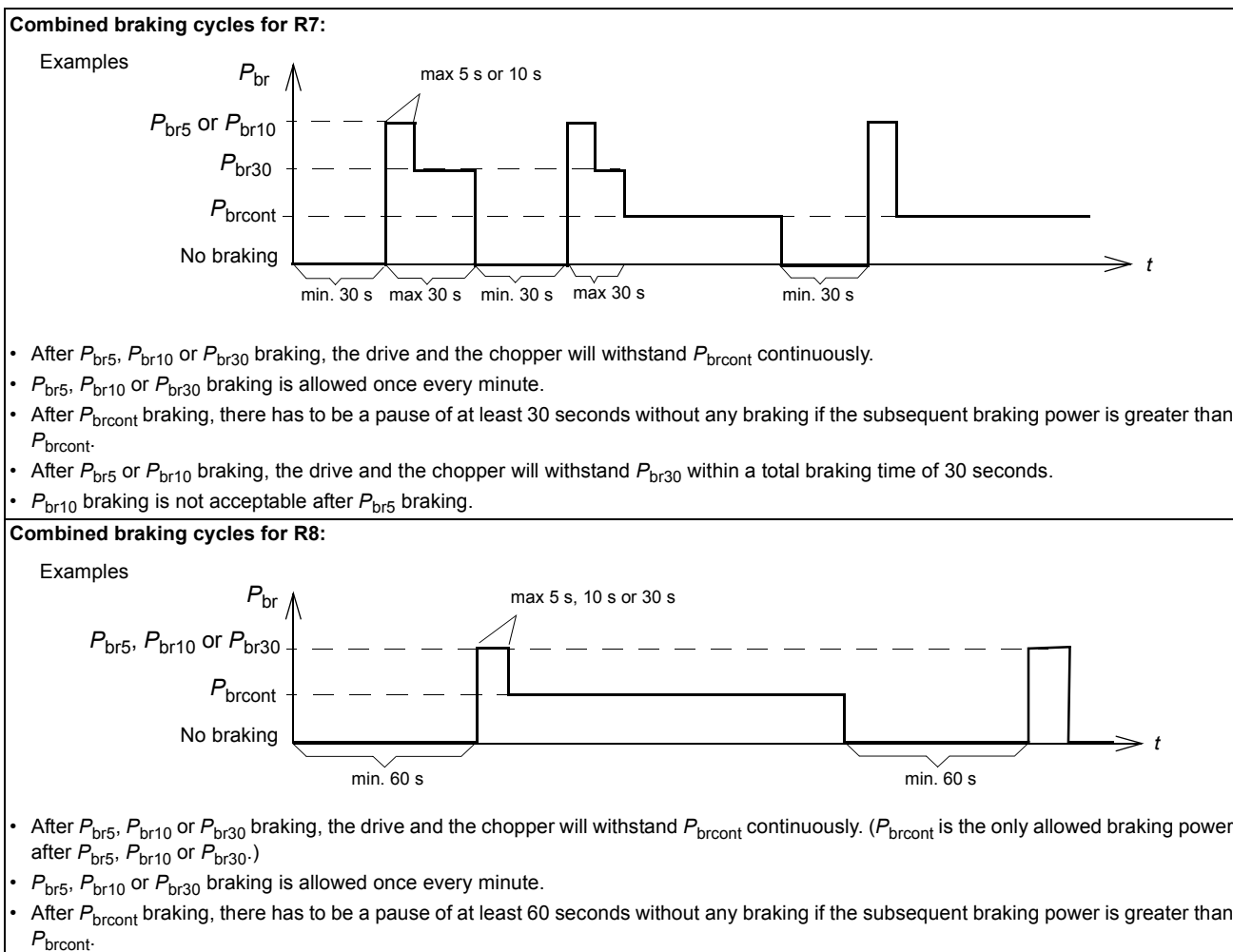

All braking resistors must be installed outside the converter module. The resistors are built in an IP 00 metal frame. The 2xSAFUR and 4xSAFUR resistors are connected in parallel. **Note:** The SAFUR resistors are not UL listed.

Resistor installation and wiring

All resistors must be installed outside the drive module in a place where they will cool.



WARNING! The materials near the brake resistor must be non-flammable. The surface temperature of the resistor is high. Air flowing from the resistor is of hundreds of degrees Celsius. Protect the resistor against contact.

Use the cable type used for drive input cabling (refer to chapter *Technical data*) to ensure the input fuses will also protect the resistor cable. Alternatively, two-conductor shielded cable with the same cross-sectional area can be used. The maximum length of the resistor cable(s) is 10 m (33 ft). For the connections, see the power connection diagram of the drive.

ACS800-07/U7

If ordered, the resistors are factory installed in a cubicle(s) next to the drive cabinet.

Protection of frame sizes R2 to R5 (ACS800-01/U1)

It is highly recommended to equip the drive with a main contactor for safety reasons. Wire the contactor so that it opens in case the resistor overheats. This is essential for safety since the drive will not otherwise be able to interrupt the main supply if the chopper remains conductive in a fault situation.

Below is a simple example wiring diagram.

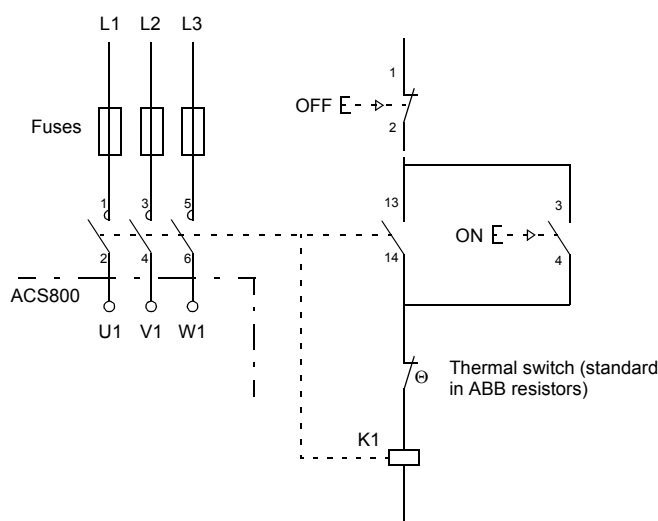

Protection of frame size R6 (ACS800-01, ACS800-07) and frame sizes R7 and R8 (ACS800-02, ACS800-04, ACS800-07)

A main contactor is not required for protecting against resistor overheating when the resistor is dimensioned according to the instructions and the internal brake chopper is in use. The drive will disable power flow through the input bridge if the chopper remains conductive in a fault situation. **Note:** If an external brake chopper (outside the drive module) is used, a main contactor is always required.

A thermal switch (standard in ABB resistors) is required for safety reasons. The cable must be shielded and not longer than the resistor cable.

With Standard Application Program, wire the thermal switch as shown below. By default, the drive will stop by coasting when the switch opens.

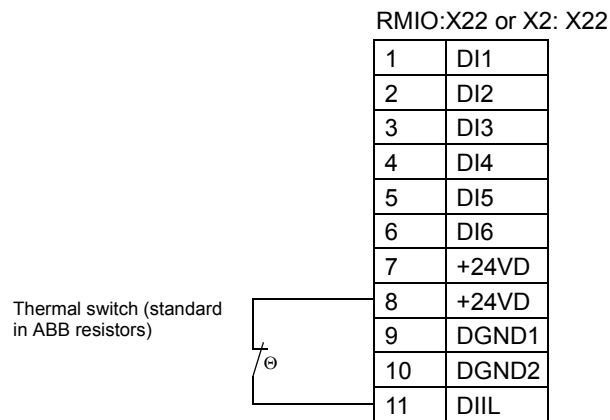

For other application programs, the thermal switch may be wired to a different digital input. Programming of the input to trip the drive by “EXTERNAL FAULT” may be needed. See the appropriate firmware manual.

Brake circuit commissioning

For Standard Application Program:

- Enable the brake chopper function (parameter 27.01).
- Switch off the overvoltage control of the drive (parameter 20.05).
- Check the resistance value setting (parameter 27.03).
- Frame sizes R6, R7 and R8: Check the setting of parameter 21.09. If stop by coasting is required, select OFF2 STOP.

For the use of the brake resistor overload protection (parameters 27.02...27.05), consult an ABB representative.



WARNING! If the drive is equipped with a brake chopper but the chopper is not enabled by parameter setting, the brake resistor must be disconnected because the protection against resistor overheating is then not in use.

For settings of other application programs, see the appropriate firmware manual.

External +24 V power supply for the RMIO board via terminal X34

What this chapter contains

This chapter describes how to connect an external +24 V power supply for the RMIO board via terminal X34. For the current consumption of the RMIO board, see chapter *Motor Control and I/O Board (RMIO)*.

Note: External power is easier to supply to the RMIO board via terminal X23, see chapter *Motor Control and I/O Board (RMIO)*.

Parameter settings

In Standard Application Program, set parameter 16.09 CTRL BOARD SUPPLY to EXTERNAL 24V if the RMIO board is powered from an external supply.

Connecting +24 V external power supply

1. Break off the tab covering the +24 VDC power input connector with pliers.
2. Lift the connector upwards.
3. Disconnect the wires from the connector (keep the connector for later use).
4. Isolate the ends of the wires individually with insulating tape.
5. Cover the isolated ends of the wires with insulating tape.
6. Push the wires inside the skeleton.
7. Connect the wires of the +24 V external power supply to the disconnected connector:
 - if a two-way connector, + wire to terminal 1 and - wire to terminal 2
 - if a three-way connector, + wire to terminal 2 and - wire to terminal 3.
8. Plug the connector in.

Frame sizes R2 to R4



Frame sizes R5 and R6

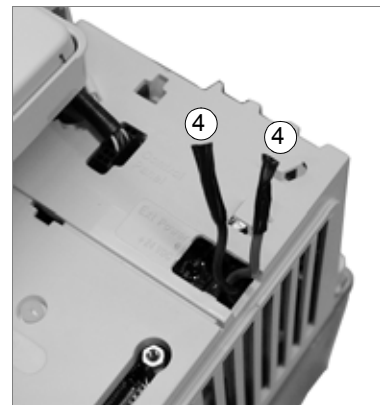
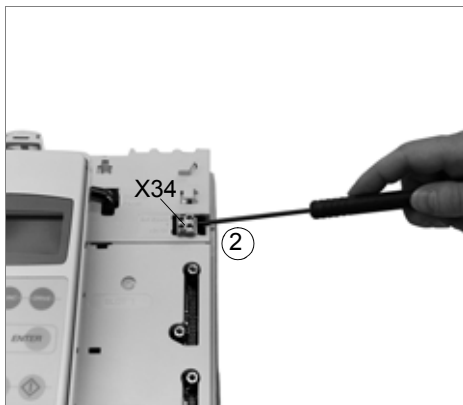
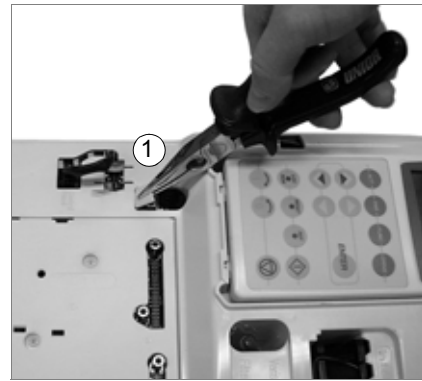

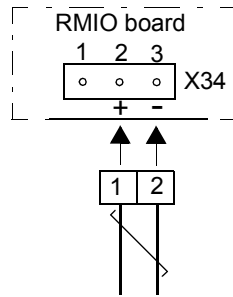
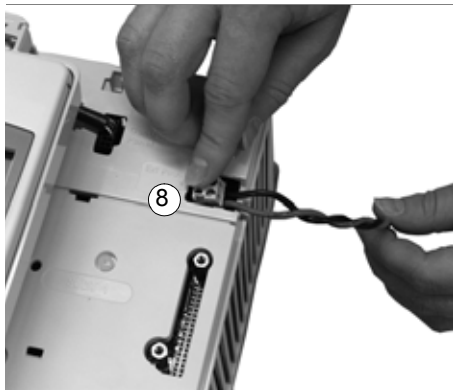
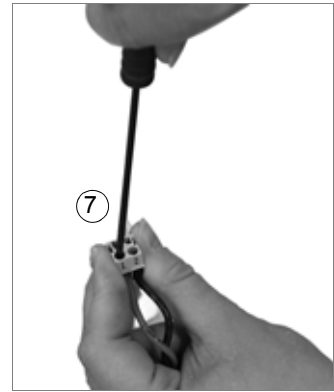
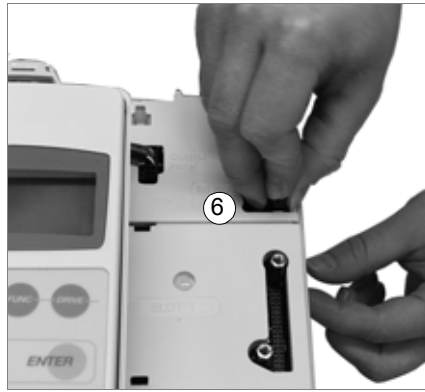
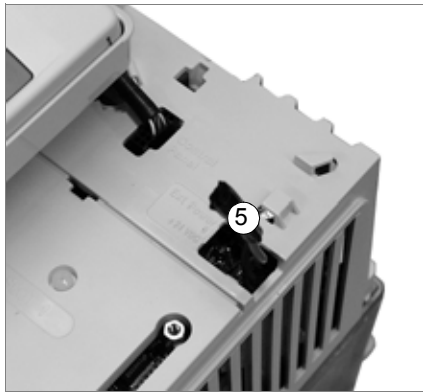

Connection of a two-way connector

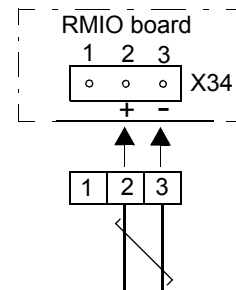

Connection of a three-way connector



ABB Oy
AC Drives
P.O. Box 184
FI-00381 HELSINKI
FINLAND
Telephone +358 10 22 11
Fax +358 10 22 22681
Internet <http://www.abb.com>

ABB Inc.
Automation Technologies
Drives & Motors
16250 West Glendale Drive
New Berlin, WI 53151
USA
Telephone 262 785-3200
800-HELP-365
Fax 262 780-5135

3AFE64382101 Rev F EN
EFFECTIVE: 16.9.2005

Dimensional drawings 15.6.2004